

**EDI-Recommendations
of GS1 Germany
Version 9.3
Food/(Non)Food**

**Purchase Order Response
(ORDRSP)**

EANCOM 2002 Syntax 3

Introduction.....	2
Business Terms.....	7
Branching Diagram.....	12
Message Structure.....	25
Segmentlayout.....	29
Codes.....	133
Example.....	286

Einführung

Introduction

The aim of the brochure on hand is to offer documentation describing the exchange of purchase order response data between business partners.

The basis of this elaboration is the international standard EANCOM® 2002. The message type ORDRSP 009 is used to transmit relevant data. GEFEG.FX (Gefeg mbH, Berlin) was used as the documentation tool.

Please be aware to know that this booklet does not replace the complete specifications in the original chapters or other relevant instructions within the EANCOM® 2002 documentation. Instead, it deals with the description of segments, data elements and codes to be used for a specific task.

The current documentation has been produced by the GS1 Germany GmbH in Cologne. GS1 Germany assumes no liability for any damages incurring from the use of this documentation. This brochure or extracts thereof may only be published or forwarded to third parties with the express written consent of GS1 Germany, which holds copyright on this work.

Important note

To fulfill the requirements of directive 2003/58/EG, article 4, C058 has been opened in NAD segments identifying a message sender. If the place in the 5 DE 3124 is not sufficient, the following RFF segments can be used, qualified with DE 1153 = GN. DE 1154 has got a capacity of 70 digits. Only in those cases, when no RFF segment follows NAD, a RFF+GN can be used in the heading section of the message. Within the EDI recommendations of GS1 Germany this is only applicable for the messages REMADV and SLSFCT.

This brochure offers different ways to start

Introduction

"Introduction" contains a short description of the respective message.

BusinessTerms

"Business Terms", is a table which links directly to the sequence numbers of the segments.

Diagram

"Diagram", is a hierarchical graphic depiction of all used segments in the same sequence as they are defined in the EANCOM® message. However, every segment is shown only once, and it is therefore possible that the sequence numbering is interrupted.

Structure

"Structure", is a list of all used segments in the same sequence as they are defined in the EANCOM® message. In general, for each piece of information one single segment is provided. Exceptions may arise when the occurrence of a segment is limited and can contain alternative information (e.g., segment BGM).

Segmentlayout

"Segmentlayout", an illustration that has been chosen to match the business terms (data from the inhouse application) with the elements from the EANCOM® syntax.

Codes

"Codes" contains a list of the codes used in the message.

Einführung

Examples

"Examples", provides at least one message example with comments. Please note that, for technical reasons, the examples can contain component data element separators, which would otherwise be represented as data element separators in the original messages.

Print

"Print" opens the PDF documentation for the corresponding message.

Scope ORDRSP

The order response is used if prices are not available as catalogue data. This is also valid if the order is not changed or a "record dues delivery" is in progress. Due to fixed prices, the price on delivery may vary to the price on order.

Only trading goods are displayed in ORDRSP. Reading copies or merchandise products are not listed.

Message structure

Heading section

Specification of buyer and supplier, message date, number and number of the referenced purchase order.

Detail section

Specification of GTIN to identify goods and services, and amendments..

Summary section

Specification of totals of the message.

Further notes

The only segments and data elements required in the Purchase Order Response are those:

Marked in the branching diagram of the Purchase Order as mandatory, including the repetitions of NAD identifying the buyer and the supplier, etc.

Changing the previous instructions, adding clarification or any other terms, in the heading section or detail section. If segments below LIN are changed then all segments below LIN must be re-transmitted.

Any change requested by the supplier to a Purchase Order may be acknowledged by the buyer by transmitting a new Purchase Order or a Purchase Order Change Request. Agreement on exact procedures should be reached between trading partners and this agreement may be included in the interchange agreement.

REFERENCES IN THE MEDIA SECTOR

Supply of goods

Einführung

The following references are used within the Media sectors to manage the supply of goods:

		ORDERS		ORDRSP		DESADV		INVOIC
H e a d i n g S e c t i o n	Order number	BGM DE 1004	⇒	RFF ON	⇒	RFF ON	⇒	RFF ON
	Order number (supplier)	BGM DE 1004	⇒	RFF VN	⇒	RFF VN	⇒	RFF VN
	Customer refer- ence number	RFF CR	⇒	RFF CR	⇒	RFF CR	⇒	RFF CR
	Sellers refer- ence number	RFF SS	⇒	RFF SS	⇒	RFF SS	⇒	RFF SS
	Promotional Deal number	RFF PD	⇒	RFF PD	⇒	RFF PD	⇒	RFF PD
	Purchase order response no.			BGM DE 1004	⇒	RFF POR	⇒	RFF POR
	Despatch advice number					BGM DE 1004	⇒	RFF AAK
	Delivery note number					RFF DQ	⇒	RFF DQ
Sales depart- ment number				⇒	RFF SD	⇒	RFF SD	
D e t a i l S e c t i o n	Sales depart- ment number	RFF SD		RFF SD	⇒	RFF SD	⇒	RFF SD
	Sellers refer- ence number	RFF SS	⇒	RFF SS	⇒	RFF SS	⇒	RFF SS
	Customer refer- ence number	RFF CR	⇒	RFF CR	⇒	RFF CR	⇒	RFF CR
	Delivery note number					RFF DQ	⇒	RFF DQ
	Promotional Deal number	RFF PD	⇒	RFF PD	⇒	RFF PD	⇒	RFF PD

BGM segments are mandatory. RFF-Segments printed in bold are depending. They must be specified in the detail section as far as a default is not defined in the heading section.

In general the customer reference number (RFF+CR) is depending. If the order is generated by the supplier (agent order, VMI) this reference is replaced by the sellers reference number (RFF+SS).

Einführung

Only one reference number is indicated, either the customer reference number or the sellers reference number.

Appendix: Codelist "Media"

To be used used in conjunction with DE 3035 = 246 and DE 1131 = MEDIA.

Lable information (ORDERS), FTX:

AF = Box number
 BF = User defined freetext
 BI = Barcode information
 EA = Lable type
 HA = Handling information
 NE = Customer name
 PT = Price text
 RN = Number of storage rack

Order qualifier (ORDERS, ORDRSP, DESADV), FTX:

	ORDERS	ORDRSP	DESADV
DUN = do not record dues (supply only if immediately available)	x	x	x
DUY = record dues (backorder if not immediately available)	x	x	x
ZRN = central settlement, no	x		
ZRY = central settlement, yes	x		
OWN = do not forward order to publisher	x		
OWY = forward order to publisher	x		
RWN = remittance, no	x		
RWY = remittance, yes	x		
ACN = consignment order, no	x		
ACY = consignment order, yes	x		
PKN = backorder, no (until agreed order volume is reached)	x	x	
PKY = backorder, yes (until agreed order volume is reached)	x	x	
TUN = do not supply replacement article	x	x	
TUY = automatic supply replacement article	x	x	
PWN = batch bonus, no	x		
PWY = batch bonus, yes	x		
FSN = order not forwarded to publisher		x	
FSY = order forwarded to publisher		x	

Einführung

Reasons for return (RETANN, RETINS), CDI:

AC = Over-shipped
AG = Delivered too late
ALP = Change of fixed retail price
AT = Item not ordered
DME = Damaged
FLG = Wrong delivery
VEV = according contract
X39 = Goods technical failings (inclusive misprints)

Instruction for returns (RETINS), CDI:

TBZ = Send back title page

Business Terms

Business Term	EANCOM-Segment		Data Element	
	Seg.-No.	Segment SG	DEG	DE
Acknowledgement request	2	UNB		0031
Additional party identification (Buyer)	27	RFF SG3#2\SG4#3	C506	1154
Additional party identification (supplier)	23	RFF SG3#1\SG4#3	C506	1154
Address for reverse routing	2	UNB	S002	0008
Application reference	2	UNB		0026
Article condition	90	ALC SG26#1\SG41#1		5463
Articles promotional variant	52	PIA SG26#1	C212	7140
Availability, (detail section)	69	DTM SG26#1	C507	2380
Backorder quantity	61	QTY SG26#1	C186	6060
Basis amount allowance/charge (line level)	92	MOA SG26#1\SG41#1\SG44#2	C516	5004
Buyers article number	48	PIA SG26#1	C212	7140
Buyers article number	51	PIA SG26#1	C212	7140
Cancellation if not delivered	9	DTM	C507	2380
Cancellation if not delivered (line item)	67	DTM SG26#1	C507	2380
Character set	2	UNB	S001	0001
Class of goods	53	PIA SG26#1	C212	7140
Colour, size	55	IMD SG26#1	C273	7008
Colour, size (coded)	55	IMD SG26#1	C273	7009
Communication number	29	COM SG3#2\SG6#1	C076	3148
Communication number receiver of goods/services	35	COM SG3#4\SG6#1	C076	3148
Component data element separator	1	UNA		UNA1
Contact person or department	28	CTA SG3#2\SG6#1	C056	3413
Contact person or department receiver of goods/services	34	CTA SG3#4\SG6#1	C056	3413
Country of receiver, coded	31	NAD SG3#4		3207
Currency code	40	CUX SG8#1	C504	6345
Currency code price	76	CUX SG26#1\SG30#2	C504	6345
Currency code price	78	CUX SG26#1\SG30#3	C504	6345
Currency code price	80	CUX SG26#1\SG30#4	C504	6345
Customer Number within the supplier system	33	RFF SG3#4\SG4#2	C506	1154
Data element separator	1	UNA		UNA2
Date of delivery	10	DTM	C507	2380
Decimal notation	1	UNA		UNA3
Delivery date, earliest	7	DTM	C507	2380
Delivery date, latest	8	DTM	C507	2380
Delivery date, requested	6	DTM	C507	2380

Business Terms

Business Term	EANCOM-Segment		Data Element	
	Seg.-No.	Segment SG	DEG	DE
Delivery date, requested (detail section)	64	DTM SG26#1	C507	2380
Despatch date, (detail section)	68	DTM SG26#1	C507	2380
Despatched quantity	60	QTY SG26#1	C186	6060
EANCOM	2	UNB		0032
Earliest delivery day (Detail section)	65	DTM SG26#1	C507	2380
ECO controlling agency	19	RFF SG1#6	C506	1154
ECO controlling agency (article)	86	RFF SG26#1\SG31#6	C506	1154
End of the transmission file, Number of messages or message groups	96	UNZ		0036
File creation date	2	UNB	S004	0017
File creation time	2	UNB	S004	0019
Fixdate for payment	41	PAT SG9#1		4279
Fixed Retail price	79	PRI SG26#1\SG30#4	C509	5118
Free Quantity	62	QTY SG26#1	C186	6060
GLN of the receiver of goods/ services	31	NAD SG3#4	C082	3039
GLN of the substitute supplier	89	NAD SG26#1\SG37#1	C082	3039
GLN of the ultimate consignee	38	NAD SG3#6	C082	3039
GTIN Global Trade Item Number	46	LIN SG26#1	C212	7140
Identification of buyer/invoicee	24	NAD SG3#2	C082	3039
Identification of invoicee	30	NAD SG3#3	C082	3039
Identification of supplier	20	NAD SG3#1	C082	3039
Indentification of the receiver of the transmission file	2	UNB	S003	0010
Indentification of the sender of the transmission file	2	UNB	S002	0004
Interchange control reference, beginnig	2	UNB		0020
Interchange control reference, end	96	UNZ		0020
Internal customer number in suppliers system	26	RFF SG3#2\SG4#2	C506	1154
Internal identification for the receiver	32	RFF SG3#4\SG4#1	C506	1154
International meter identification	45	LOC SG10#1\SG11#1	C517	3224
Latest delivery date (Detail section)	66	DTM SG26#1	C507	2380
Line item number	46	LIN SG26#1		1082
Line item reference (line level)	85	RFF SG26#1\SG31#5	C506	1154
Line number from order indicator (Line item reference).	85	RFF SG26#1\SG31#5	C506	1156

Business Terms

Business Term	EANCOM-Segment		Data Element	
	Seg.-No.	Segment SG	DEG	DE
List price per ordered unit	74 PRI	SG26#1\SG30#1	C509	5118
Message reference number	3 UNH			0062
Minimum remaining time / shelf-life	63 DTM	SG26#1	C507	2380
Name 1 of the receiver	31 NAD	SG3#4	C080	3036
Name 1 of the ultimate consignee	38 NAD	SG3#6	C080	3036
Name 2 of the receiver	31 NAD	SG3#4	C080	3036
Name 2 of the ultimate consignee	38 NAD	SG3#6	C080	3036
Name 3 of the receiver	31 NAD	SG3#4	C080	3036
Name 3 of the ultimate consignee	38 NAD	SG3#6	C080	3036
Net retail price	75 PRI	SG26#1\SG30#2	C509	5118
Number of layers per charge carrier	56 MEA	SG26#1	C174	6314
Number of packages	87 PAC	SG26#1\SG32#1		7224
Number of periods (days) for payment	43 PAT	SG9#2	C112	2152
Number of salesdepartment	83 RFF	SG26#1\SG31#3	C506	1154
Number of units per layer	57 MEA	SG26#1	C174	6314
Order confirmation date	5 DTM		C507	2380
Order number	13 RFF	SG1#1	C506	1154
Order number supplier	17 RFF	SG1#4	C506	1154
Order qualifier	72 FTX	SG26#1	C107	4441
Order reference	15 RFF	SG1#2	C506	1154
Order reference	81 RFF	SG26#1\SG31#1	C506	1154
Ordering date	14 DTM	SG1#1	C507	2380
Originally ordered quantity	59 QTY	SG26#1	C186	6060
Partial Order, Status	12 ALI			4183
Password interchange	2 UNB		S005	0022
Payment terms	43 PAT	SG9#2		4279
Percentage of allowance/charge	91 PCD	SG26#1\SG41#1\SG43#1	C501	5482
Pick up place additional identification	37 RFF	SG3#5\SG4#1	C506	1154
Pick up place city/town	36 NAD	SG3#5		3164
Pick up place identification	36 NAD	SG3#5	C082	3039
Pick up place Name 1	36 NAD	SG3#5	C080	3036
Pick up place Name 2	36 NAD	SG3#5	C080	3036
Pick up place Name 3	36 NAD	SG3#5	C080	3036
Pick up place postal code	36 NAD	SG3#5		3251
Pick up place street	36 NAD	SG3#5	C059	3042

Business Terms

Business Term	EANCOM-Segment		Data Element	
	Seg.-No.	Segment SG	DEG	DE
Place of receiver - name of a city (town, village) for addressing purposes.	31	NAD SG3#4		3164
Place of ultimate consignee - name of a city (town, village) for addressing purposes.	38	NAD SG3#6		3164
Postcode of receiver	31	NAD SG3#4		3251
Postcode of ultimate consignee	38	NAD SG3#6		3251
Promotion deal number	18	RFF SG1#5	C506	1154
Promotion deal number (line level)	84	RFF SG26#1\SG31#4	C506	1154
Purchase order response number	4	BGM	C106	1004
Quantity difference	71	QVR SG26#1	C279	6064
Reason qualifier	73	FTX SG26#1	C107	4441
Release character	1	UNA		UNA4
Reserved for future use	1	UNA		UNA5
Routing address	2	UNB	S003	0014
Schedule (Detail section)	70	DTM SG26#1	C507	2380
Schedule, (Header section)	11	DTM	C507	2380
Segment terminator	1	UNA		UNA6
Sellers reference number	16	RFF SG1#3	C506	1154
Sellers reference number	82	RFF SG26#1\SG31#2	C506	1154
Statements on business letters	21	RFF SG3#1\SG4#1	C506	1154
Statements on business letters	25	RFF SG3#2\SG4#1	C506	1154
Street and number of receiver	31	NAD SG3#4	C059	3042
Street of ultimate consignee	38	NAD SG3#6	C059	3042
Substitute article	49	PIA SG26#1	C212	7140
Substitute article long description	54	IMD SG26#1	C273	7008
Suggested retail price	77	PRI SG26#1\SG30#3	C509	5118
Supplier's article number	47	PIA SG26#1	C212	7140
Supplier/issuer of invoice VAT registration number	22	RFF SG3#1\SG4#2	C506	1154
Suppliers article number (secondary indent.)	50	PIA SG26#1	C212	7140
Syntax version	2	UNB	S001	0002
Test indicator	2	UNB		0035
Total line items amount	94	MOA	C516	5004
Total number of segments in the message	95	UNT		0074
Transport means	44	TDT SG10#1	C228	8179
Type of document	4	BGM	C002	1001
Type of package	87	PAC SG26#1\SG32#1	C202	7065
Value added tax on document level	39	TAX SG7#1	C241	5153

Business Terms

Business Term	EANCOM-Segment		Data Element	
	Seg.-No.	Segment SG	DEG	DE
Value added tax on line level	88 TAX	SG26#1\SG36#1	C241	5153
Value date	42 DTM	SG9#1	C507	2380
Weight of the article	58 MEA	SG26#1	C174	6314

Branching Diagram

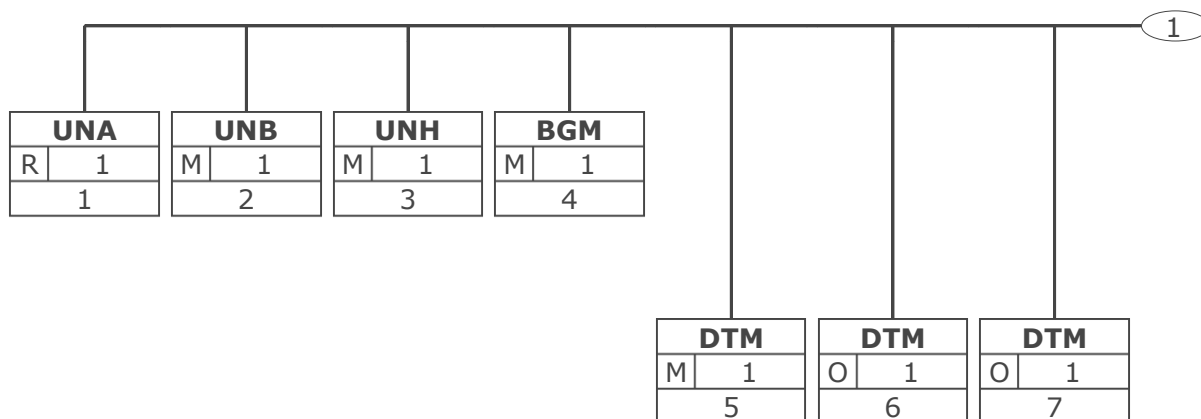

Tag	Tag = Segment/Group Tag	
St	MaxOcc	St = Status (M=Mandatory, C=Conditional, R=Required, O=Optional, A=Advised, D=Dependent)
No	MaxOcc = Maximum occurrence of the segment/group; No = Consecutive segment number	

Branching Diagram

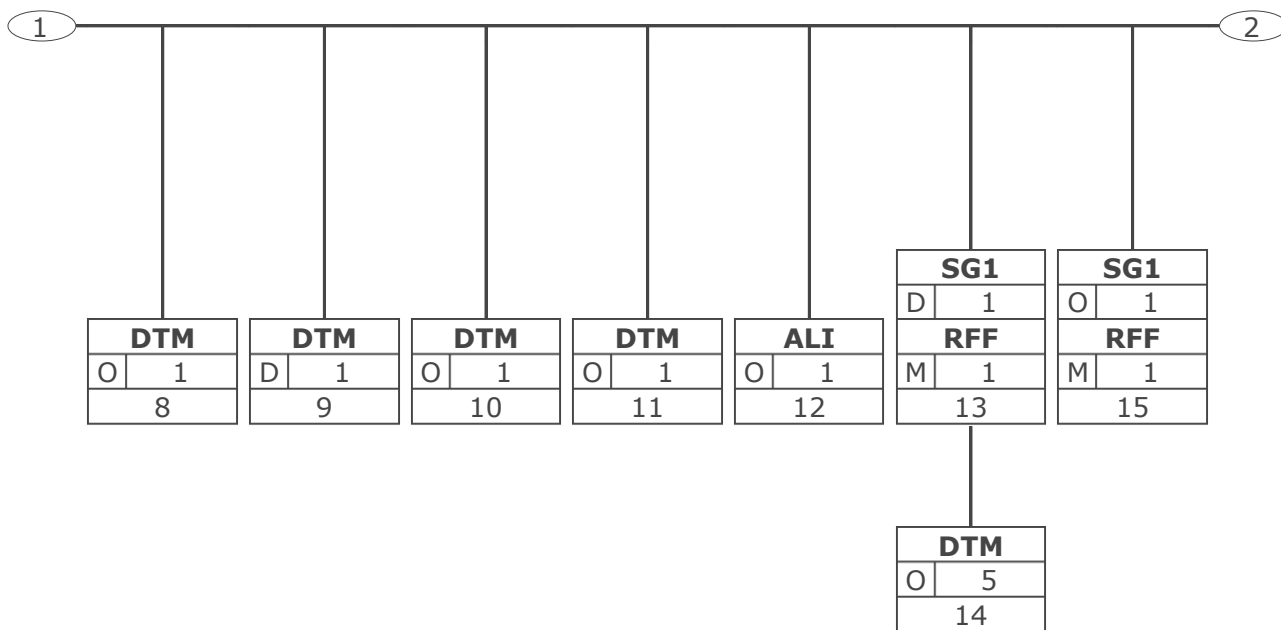

Tag	Tag = Segment/Group Tag
St MaxOcc	St = Status (M=Mandatory, C=Conditional, R=Required, O=Optional, A=Advised, D=Dependent)
No	MaxOcc = Maximum occurrence of the segment/group; No = Consecutive segment number

Branching Diagram

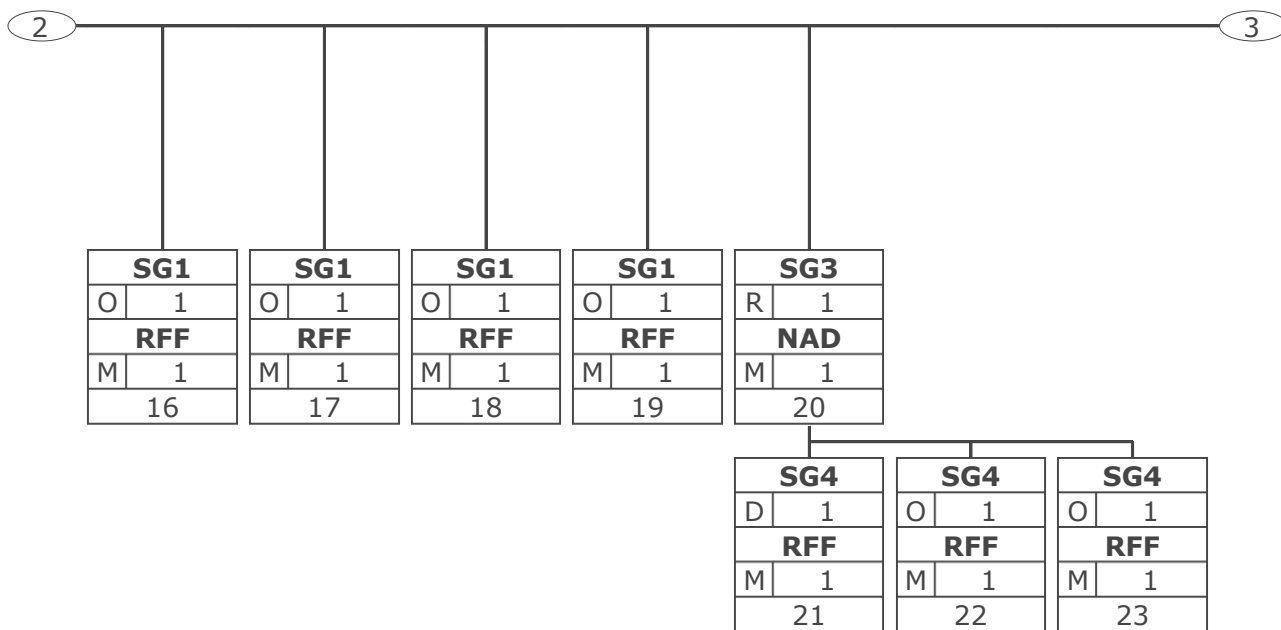

Tag	Tag = Segment/Group Tag
St MaxOcc	St = Status (M=Mandatory, C=Conditional, R=Required, O=Optional, A=Advised, D=Dependent)
No	MaxOcc = Maximum occurrence of the segment/group; No = Consecutive segment number

Branching Diagram

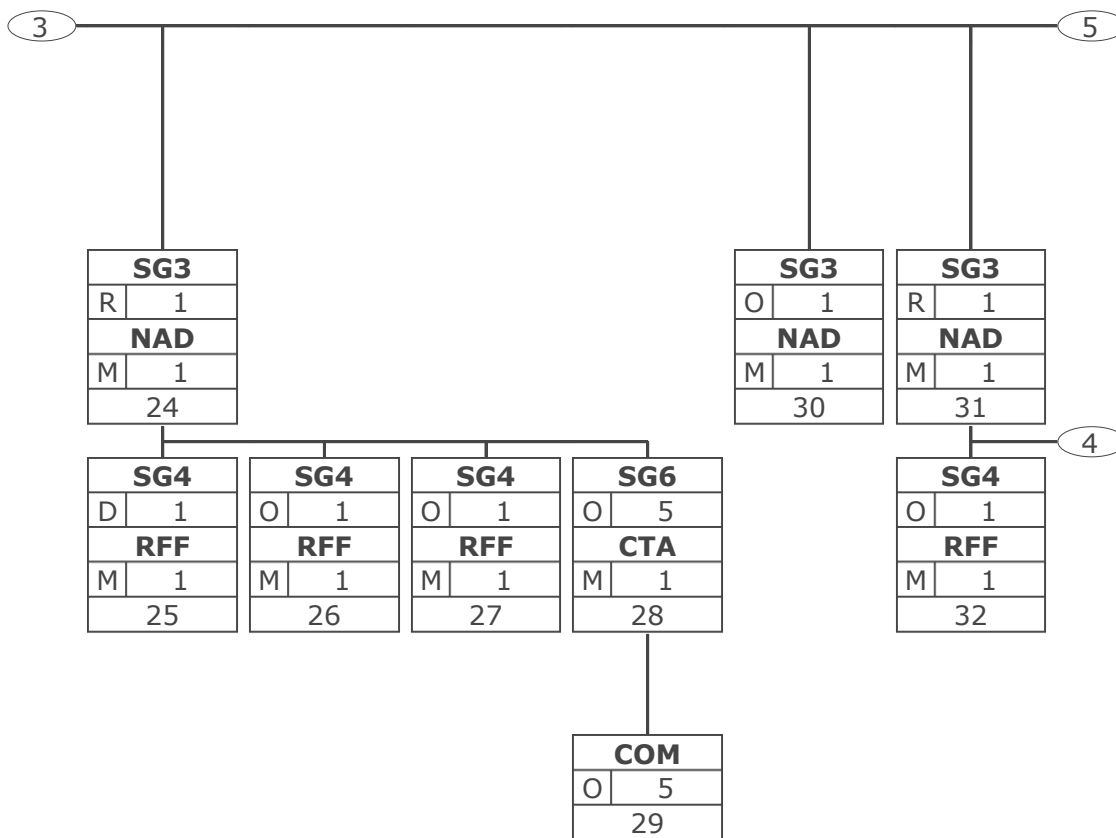

Tag	Tag = Segment/Group Tag
St	MaxOcc St = Status (M=Mandatory, C=Conditional, R=Required, O=Optional, A=Advised, D=Dependent)
No	MaxOcc = Maximum occurrence of the segment/group; No = Consecutive segment number

Branching Diagram

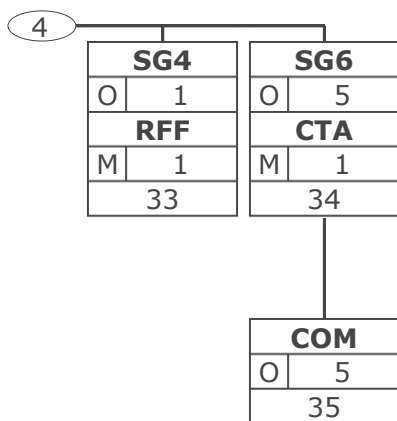

Tag	
St	MaxOcc
No	

Tag = Segment/Group Tag
 St = Status (M=Mandatory, C=Conditional, R=Required, O=Optional, A=Advised, D=Dependent)
 MaxOcc = Maximum occurrence of the segment/group; No = Consecutive segment number

Branching Diagram

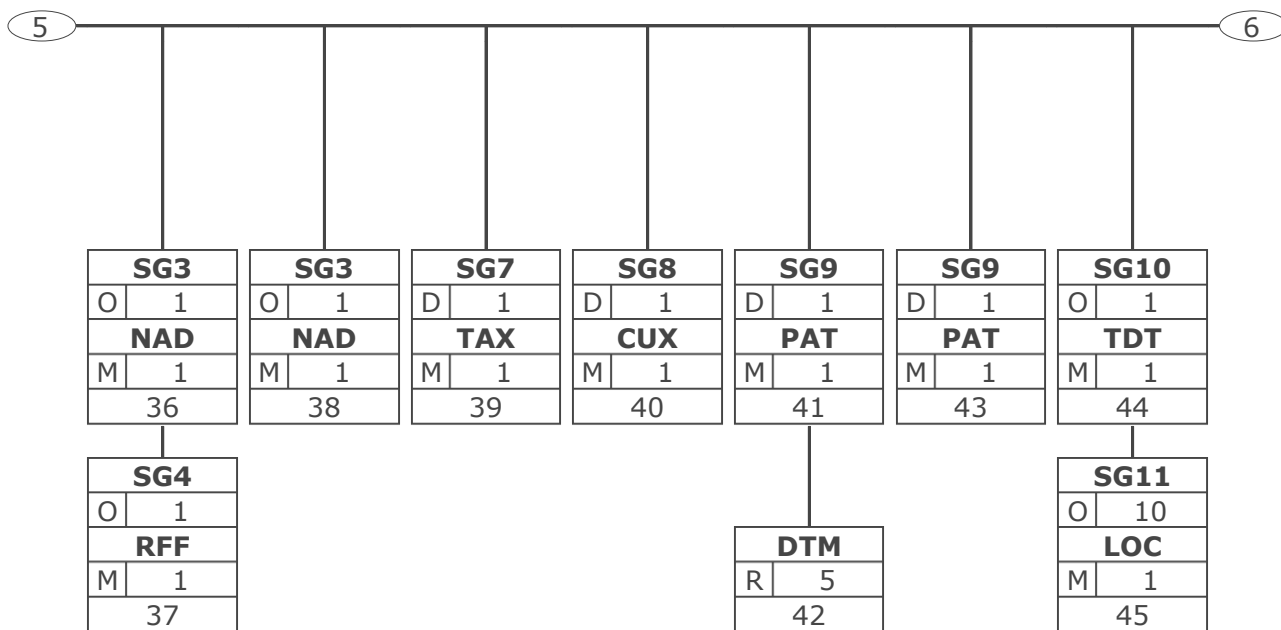

Tag	Tag = Segment/Group Tag
St MaxOcc	St = Status (M=Mandatory, C=Conditional, R=Required, O=Optional, A=Advised, D=Dependent)
No	MaxOcc = Maximum occurrence of the segment/group; No = Consecutive segment number

Branching Diagram

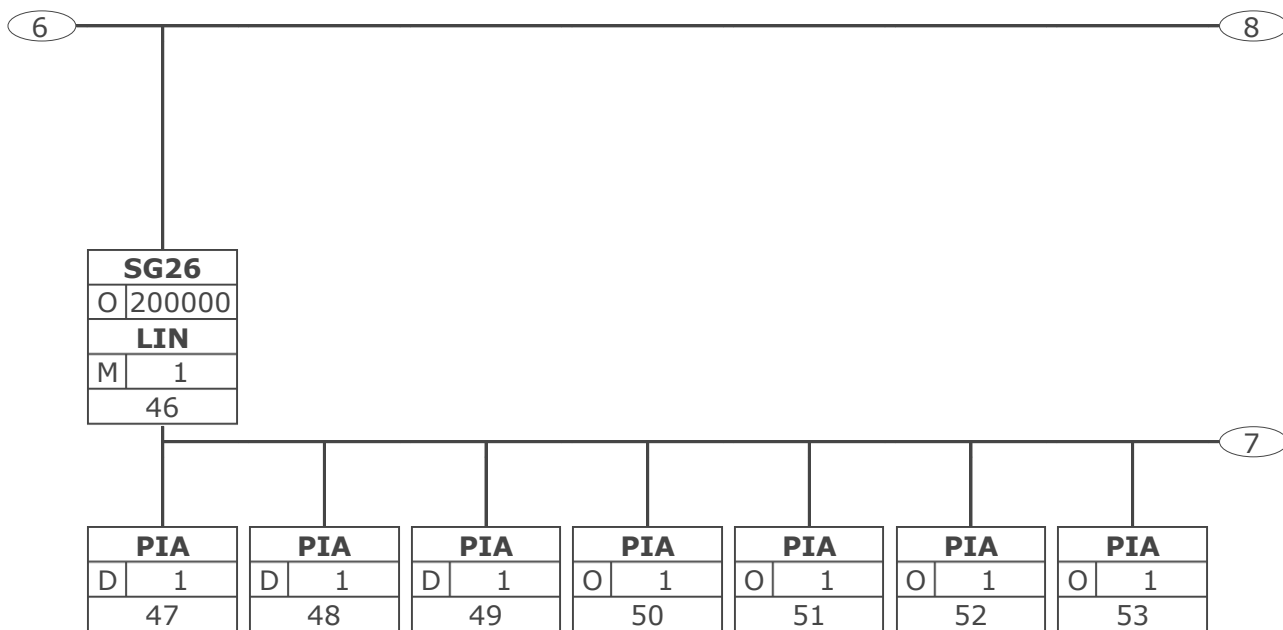

Tag	Tag = Segment/Group Tag
St MaxOcc	St = Status (M=Mandatory, C=Conditional, R=Required, O=Optional, A=Advised, D=Dependent)
No	MaxOcc = Maximum occurrence of the segment/group; No = Consecutive segment number

Branching Diagram

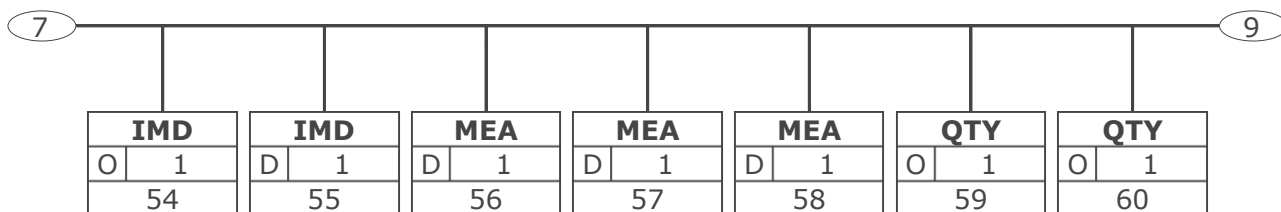

Tag	Tag = Segment/Group Tag
St MaxOcc	St = Status (M=Mandatory, C=Conditional, R=Required, O=Optional, A=Advised, D=Dependent)
No	MaxOcc = Maximum occurrence of the segment/group; No = Consecutive segment number

Branching Diagram

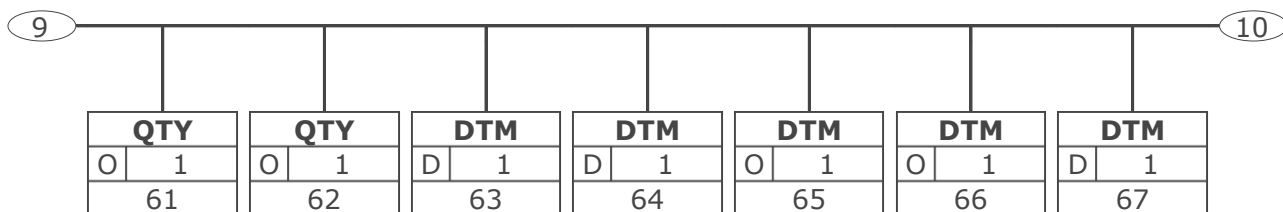

Tag	Tag = Segment/Group Tag
St MaxOcc	St = Status (M=Mandatory, C=Conditional, R=Required, O=Optional, A=Advised, D=Dependent)
No	MaxOcc = Maximum occurrence of the segment/group; No = Consecutive segment number

Branching Diagram

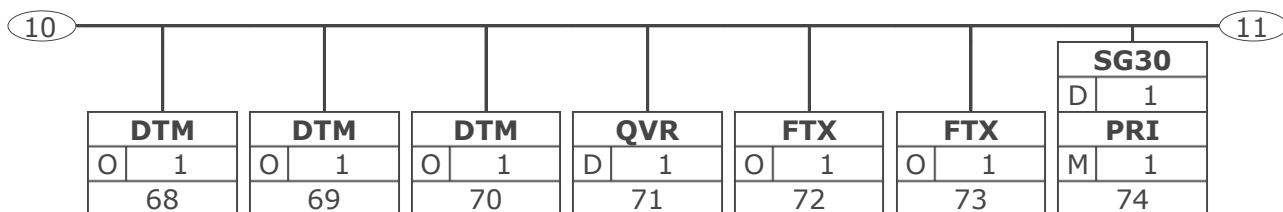

Tag	Tag = Segment/Group Tag
St	MaxOcc St = Status (M=Mandatory, C=Conditional, R=Required, O=Optional, A=Advised, D=Dependent)
No	MaxOcc = Maximum occurrence of the segment/group; No = Consecutive segment number

Branching Diagram

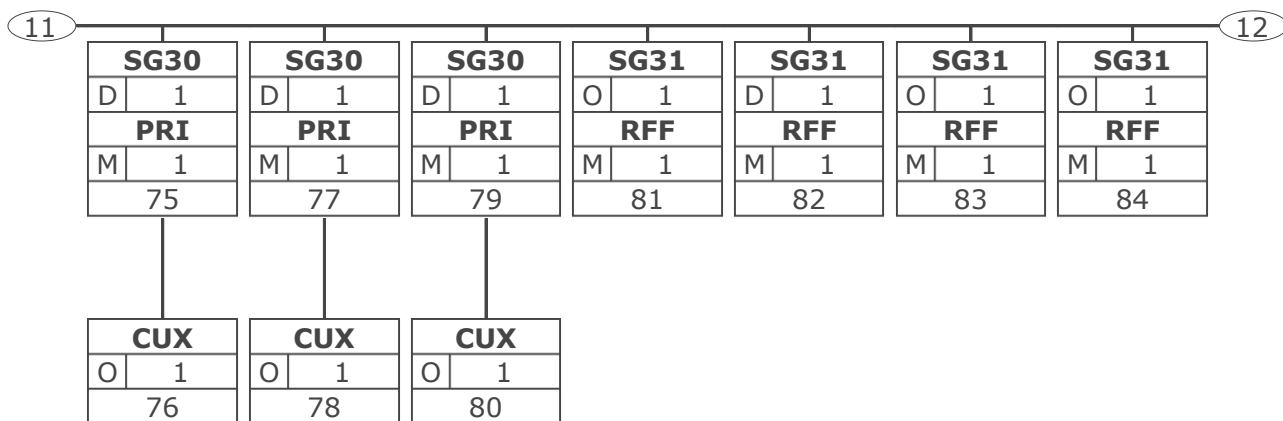

Tag	Tag = Segment/Group Tag
St MaxOcc	St = Status (M=Mandatory, C=Conditional, R=Required, O=Optional, A=Advised, D=Dependent)
No	MaxOcc = Maximum occurrence of the segment/group; No = Consecutive segment number

Branching Diagram

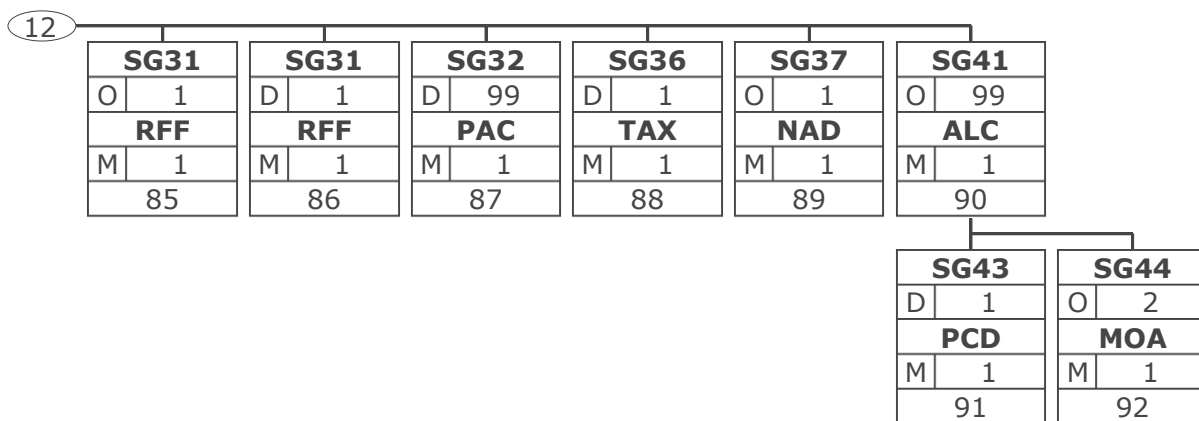

Tag	Tag = Segment/Group Tag
St MaxOcc	St = Status (M=Mandatory, C=Conditional, R=Required, O=Optional, A=Advised, D=Dependent)
No	MaxOcc = Maximum occurrence of the segment/group; No = Consecutive segment number

Branching Diagram

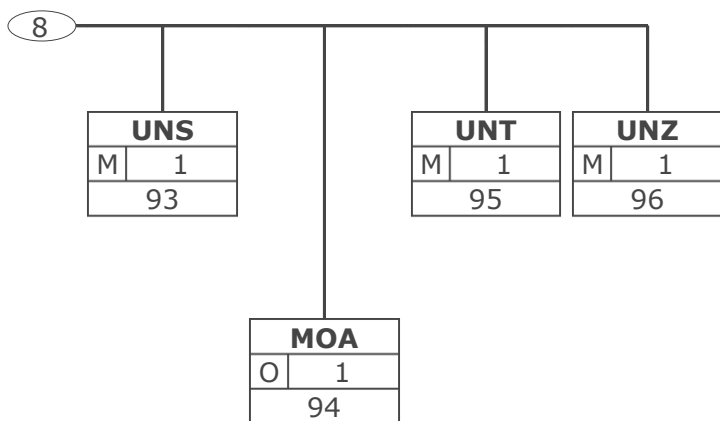

Tag	Tag = Segment/Group Tag
St MaxOcc	St = Status (M=Mandatory, C=Conditional, R=Required, O=Optional, A=Advised, D=Dependent)
No	MaxOcc = Maximum occurrence of the segment/group; No = Consecutive segment number

Message Structure

Seg.	No.	Status	Max Occ	Segment
UNA	1	R	1	Used character set
UNB	2	M	1	Beginning of transmission file
Heading section				
UNH	3	M	1	Beginn of message
BGM	4	M	1	Purchase order response number
DTM	5	M	1	Order confirmation date (time)
DTM	6	O	1	Delivery date, requested
DTM	7	O	1	Delivery date, earliest
DTM	8	O	1	Delivery date, latest
DTM	9	D	1	Cancellation if not delivered
DTM	10	O	1	Date of Delivery
DTM	11	O	1	Delivery date / time, current schedule
ALI	12	O	1	Partial order
SG1		D	1	RFF-DTM
RFF	13	M	1	Order number
DTM	14	O	5	Ordering date
SG1		O	1	RFF-DTM
RFF	15	M	1	Order reference
SG1		O	1	RFF-DTM
RFF	16	M	1	Sellers reference
SG1		O	1	RFF-DTM
RFF	17	M	1	Order number supplier
SG1		O	1	RFF-DTM
RFF	18	M	1	Promotion deal number
SG1		O	1	RFF-DTM
RFF	19	M	1	BIO-ECO Labelling
SG3		R	1	NAD-LOC-FII-SG4-SG6
NAD	20	M	1	Identification of supplier
SG4		D	1	RFF
RFF	21	M	1	Statements on business letters
SG4		O	1	RFF
RFF	22	M	1	Supplier/issuer of invoice VAT registration number
SG4		O	1	RFF
RFF	23	M	1	Additional party identification (supplier)
SG3		R	1	NAD-LOC-FII-SG4-SG6
NAD	24	M	1	Identification of buyer/invoicee
SG4		D	1	RFF
RFF	25	M	1	Statements on business letters
SG4		O	1	RFF
RFF	26	M	1	Internal customer number in suppliers system
SG4		O	1	RFF
RFF	27	M	1	Additional party identification (Buyer)
SG6		O	5	CTA-COM
CTA	28	M	1	Contact person or department
COM	29	O	5	Communication number
SG3		O	1	NAD-LOC-FII-SG4-SG6
NAD	30	M	1	Identification of invoicee

Max. Occ. = Maximum occurrence of the segment/group, Status: M=Mandatory, C=Conditional, R=Required, O=Optional, A=Advised, D=Dependent

Message Structure

Seg.	No.	Status	Max Occ	Segment
SG3		R	1	NAD-LOC-FII-SG4-SG6
NAD	31	M	1	GLN of the receiver of goods/services
SG4		O	1	RFF
RFF	32	M	1	Internal identification for the receiver
SG4		O	1	RFF
RFF	33	M	1	Customer number in the supplier system
SG6		O	5	CTA-COM
CTA	34	M	1	Contact person or department receiver of goods/services
COM	35	O	5	Communication number receiver of goods/services
SG3		O	1	NAD-LOC-FII-SG4-SG6
NAD	36	M	1	Pick up place identification
SG4		O	1	RFF
RFF	37	M	1	Pick up place additional identification
SG3		O	1	NAD-LOC-FII-SG4-SG6
NAD	38	M	1	GLN of the ultimate consignee
SG7		D	1	TAX-MOA
TAX	39	M	1	Value added tax on document level
SG8		D	1	CUX-DTM
CUX	40	M	1	Currency code
SG9		D	1	PAT-DTM-PCD-MOA
PAT	41	M	1	Fixdate for payment
DTM	42	R	5	Value date
SG9		D	1	PAT-DTM-PCD-MOA
PAT	43	M	1	Payment terms
SG10		O	1	TDT-SG11
TDT	44	M	1	Transport means
SG11		O	10	LOC-DTM
LOC	45	M	1	Meter identification
Detail section				
SG26		O	200000	LIN-PIA-IMD-MEA-QTY-ALI-DTM-MOA-GIN-QVR-FTX-SG30-SG31-SG32-SG35-SG36-SG37-SG41-SG47
LIN	46	M	1	GTIN
PIA	47	D	1	Suppliers article number
PIA	48	D	1	Buyers article number
PIA	49	D	1	Substitute article
PIA	50	O	1	Suppliers article number (secondary indent.)
PIA	51	O	1	Buyers article number
PIA	52	O	1	Articles promotional variant
PIA	53	O	1	Class of goods
IMD	54	O	1	Description of the substitute
IMD	55	D	1	Colour, size
MEA	56	D	1	Number of layers per charge carrier
MEA	57	D	1	Number of units per layer
MEA	58	D	1	Weight of the article
QTY	59	O	1	Ordered quantity
QTY	60	O	1	Despatched quantity

Max. Occ. = Maximum occurrence of the segment/group, Status: M=Mandatory, C=Conditional, R=Required, O=Optional, A=Advised, D=Dependent

Message Structure

Seg.	No.	Status	Max Occ	Segment
QTY	61	O	1	Backorder quantity
QTY	62	O	1	Free quantity book
DTM	63	D	1	Minimum remaining time / shelf-life
DTM	64	D	1	Delivery date/time, requested
DTM	65	O	1	Earliest delivery day
DTM	66	O	1	Latest delivery time
DTM	67	D	1	Cancellation if not delivered (Position)
DTM	68	O	1	Despatch date/time (line item)
DTM	69	O	1	Availability (line item)
DTM	70	O	1	Delivery date / time, current schedule
QVR	71	D	1	Quantity difference
FTX	72	O	1	Order qualifier
FTX	73	O	1	Reason qualifier
SG30		D	1	PRI-CUX-DTM
PRI	74	M	1	List price per ordered unit
SG30		D	1	PRI-CUX-DTM
PRI	75	M	1	Net sale price
CUX	76	O	1	Currency code of net sale price
SG30		D	1	PRI-CUX-DTM
PRI	77	M	1	Recommended gross sale price
CUX	78	O	1	Currency code of recommended sale price
SG30		D	1	PRI-CUX-DTM
PRI	79	M	1	Fixed Retail price
CUX	80	O	1	Currency code of fixed retail price
SG31		O	1	RFF-DTM
RFF	81	M	1	Order reference
SG31		D	1	RFF-DTM
RFF	82	M	1	Sellers reference
SG31		O	1	RFF-DTM
RFF	83	M	1	Department reference
SG31		O	1	RFF-DTM
RFF	84	M	1	Promotion deal number
SG31		O	1	RFF-DTM
RFF	85	M	1	Order indicator (Line item reference)
SG31		D	1	RFF-DTM
RFF	86	M	1	BIO-ECO Labelling
SG32		D	99	PAC-QTY-SG34
PAC	87	M	1	Packaging details
SG36		D	1	TAX-MOA
TAX	88	M	1	Value added tax on line level
SG37		O	1	NAD-SG40
NAD	89	M	1	Substitute supplier identification
SG41		O	99	ALC-ALI-DTM-SG42-SG43-SG44- SG45-SG46
ALC	90	M	1	Article condition
SG43		D	1	PCD-RNG
PCD	91	M	1	Allowance or charge in percent
SG44		O	2	MOA-RNG

Max. Occ. = Maximum occurrence of the segment/group, Status: M=Mandatory, C=Conditional, R=Required, O=Optional, A=Advised, D=Dependent

Message Structure

Seg.	No.	Status	Max Occ	Segment
MOA	92	M	1	Basis amount allowance/charge (line level)
Summary section				
UNS	93	M	1	Section control
MOA	94	O	1	Total line items amount
UNT	95	M	1	Number of segments in the message
UNZ	96	M	1	End of the transmission file

Max. Occ. = Maximum occurrence of the segment/group, Status: M=Mandatory, C=Conditional, R=Required, O=Optional, A=Advised, D=Dependent

Segment Layout

No. Seg	St	Max. Occ.			
1	UNA	R 1	Service string advice		
To define the characters selected for use as delimiters and indicators in the rest of the interchange that follows.					
Business Term	DE	EDIFACT	Format	St	* Description
Component data element separator	UNA1	Component data element separator	an1	M	Default value: ":"
Data element separator	UNA2	Data element separator	an1	M	Default value: "+"
Decimal notation	UNA3	Decimal notation	an1	M	Default value: "."
Release character	UNA4	Release indicator	an1	M	Default value: "?"
Reserved for future use	UNA5	Reserved for future use	an1	M	(Default value: space)
Segment terminator	UNA6	Segment terminator	an1	M	Default value: "' '
Segmentstatus: Mandatory					
The use of the UNA segment is mandatory, if character set "A" (UNB,DE0001) is not used.					
For international EDI the use of character set UNOA is recommended. For national (German) EDI the use of UNOC is reasonable because it contains lower case letters and umlauts.					
Example: UNA:+.?' '					
The UNA segment contains the default service string characters.					

Max. Occ. = Maximum Occurrence, St = Status, * = Restricted Codes
 Status: M=Mandatory, R=Required, O=Optional, D=Dependent, A=Advised, N=Not used

Segment Layout

No. Seg	St	Max. Occ.				
2	UNB	M 1	Interchange header To start, identify and specify an interchange.			
Business Term	DE	EDIFACT	Format	St	*	Description
	S001	Syntax identifier		M		
Character set	0001	Syntax identifier	a4	M	*	UNOA UN/ECE level A UNOB UN/ECE level B UNOC UN/ECE level C UNOD UN/ECE level D UNOE UN/ECE level E UNOF UN/ECE level F
Syntax version	0002	Syntax version number	n1	M	*	3 Version 3
	S002	Interchange sender		M		
Indentification of the sender of the transmission file	0004	Sender identification	an..35	M		= Global Location Number (GLN)
	0007	Partner identification code qualifier	an..4	R	*	14 GS1
Address for reverse routing	0008	Address for reverse routing	an..14	O		See note
	S003	Interchange recipient		M		
Indentification of the receiver of the transmission file	0010	Recipient identification	an..35	M		= Global Location Number (GLN)
	0007	Partner identification code qualifier	an..4	R	*	14 GS1
Routing address	0014	Routing address	an..14	O		See note
	S004	Date/time of preparation		M		
File creation date	0017	Date of preparation	n6	M		= Dateformat JJMMTT
File creation time	0019	Time of preparation	n4	M		= Timeformat HHMM
Interchange control reference, beginnig	0020	Interchange control reference	an..14	M		= Unique senders reference
	S005	Recipient's reference, password		O		
Password interchange	0022	Recipient's reference/ password	an..14	M		
	0025	Recipient's reference/ password qualifier	an2	O	*	AA Reference BB Password
Application reference	0026	Application reference	an..14	O		Message type if the transmission fole contains only one message type
	0029	Processing priority code	a1	O	*	A Highest priority
Acknowledgement request	0031	Acknowledgement request	n1	O		
EANCOM	0032	Communications agreement ID	an..35	R		= EANCOM... EDIFACT subset identification (see note)
Test indicator	0035	Test indicator	n1	O	*	1 Interchange is a

Max. Occ. = Maximum Occurrence, St = Status, * = Restricted Codes

Status: M=Mandatory, R=Required, O=Optional, D=Dependent, A=Advised, N=Not used

Segment Layout

Business Term	DE	EDIFACT	Format	St	*	Description
						test
<p>Segmentstatus: Mandatory</p> <p>For international EDI the use of character set UNOA is recommended. For national (German) EDI the use of UNOC is reasonable because it contains lower case letters and umlauts.</p> <p>Note DE 0008: The address for reverse routing is provided by the interchange sender to inform the interchange recipient of the address within the sender's (source) system to which responding interchanges must be sent. It is recommended that the GLN be used for this purpose.</p> <p>Note DE 0014: The routing address is used to identify the receiver, if a provider adds service values for the actual receiver (e.g. consolidated companies, corporate group). The use of the identification system (e.g. GLN) has to be agreed bilaterally.</p> <p>Note DE 0020: This data element must contain a consistent sequential number per interchange between sender and receiver of the transmission.</p> <p>Note DE 0032: This data element is used to identify any underlying agreements which control the exchange of data. Within EANCOM , the identity of such agreements must start with the letters 'EANCOM', the remaining characters within the data element being filled according to bilateral agreements.</p> <p>Example: UNB+UNOC:3+4012345000009:14:4012345000018+4000004000002:14:4000004000099+181013:1043+4711+REF:AA+++EANCOM+1' The EANCOM file 4711 dated 13.10.2018, 10 h 43 is sent by the issuer identified with GLN 4012345000009 to the receiver identified with GLN 4000004000002.</p>						

Max. Occ. = Maximum Occurrence, St = Status, * = Restricted Codes
 Status: M=Mandatory, R=Required, O=Optional, D=Dependent, A=Advised, N=Not used

Segment Layout

Heading section
Heading section

No. Seg	St	Max. Occ.				
3	UNH	M 1	Message header To head, identify and specify a message.			
Business Term	DE	EDIFACT	Format	St	*	Description
Message reference number	0062	Message reference number	an..14	M		Sender's unique message reference. Sequence number of messages in the interchange. DE 0062 in UNT will have the same value. Generated by the sender.
	S009	Message identifier		M		
	0065	Message type	an..6	M	*	ORDRSP Purchase order response message
	0052	Message version number	an..3	M	*	D Draft version/ UN/EDIFACT Directory
	0054	Message release number	an..3	M	*	01B Release 2001 - B
	0051	Controlling agency	an..2	M	*	UN UN/CEFACT
	0057	Association assigned code	an..6	R	*	EAN009 GS1 version control number (GS1 Permanent Code)
Segmentstatus: Mandatory						
This segment is used to head, identify and specify a message.						
Example: UNH+1+ORDRSP:D:01B:UN:EAN009'						
Identification data of the ORDRSP message. The message reference number "1" must be repeated in the UNT segment at the end of the message.						

Max. Occ. = Maximum Occurrence, St = Status, * = Restricted Codes
Status: M=Mandatory, R=Required, O=Optional, D=Dependent, A=Advised, N=Not used

Segment Layout

Heading section

No. Seg	St	Max. Occ.				
4	BGM	M 1	Beginning of message To indicate the type and function of a message and to transmit the identifying number.			
Business Term	DE	EDIFACT	Format	St	*	Description
	C002	Document/message name		R		
Type of document	1001	Document name code	an..3	R	*	231 Purchase order response
	1131	Code list identification code	an..17	N		
	3055	Code list responsible agency code	an..3	N		
	1000	Document name	an..35	O		
	C106	Document/message identification		R		
Purchase order response number	1004	Document identifier	an..35	R		Purchase order response number assigned by document sender
	1225	Message function code	an..3	R	*	4 Change 27 Not accepted 29 Accepted without amendment

Segmentstatus: Mandatory

This segment is used to indicate the type and function of a message and to transmit the identifying number.

Note to DE 1225:

The message function, coded is a critical element in this segment. The restricted codes detailed in DE 1225 have the following definitions:

4 = Change - The supplier accepts to supply the goods or services requested in the Purchase Order or Purchase Order Change Request, but requires changes to one or more of the items.

27 = Not accepted - The supplier declines to supply the goods detailed in a Purchase Order or Purchase Order Change Request.

29 = Accepted without amendment - The supplier accepts to supply the goods or services requested according to the terms set out in the Purchase Order or Purchase Order Change Request.

Example: `BGM+231:::X+128222+29'`

The order response has the number 128222.

Max. Occ. = Maximum Occurrence, St = Status, * = Restricted Codes
Status: M=Mandatory, R=Required, O=Optional, D=Dependent, A=Advised, N=Not used

Segment Layout

Heading section

No. Seg	St	Max. Occ.				
5	DTM	M 1	Date/time/period To specify date, and/or time, or period.			
Business Term	DE	EDIFACT	Format	St	*	Description
	C507	Date/time/period		M		
	2005	Date or time or period function code qualifier	an..3	M	*	137 Document/ message date/ time
Order confirmation date	2380	Date or time or period value	an..35	R		
	2379	Date or time or period format code	an..3	R		102 CCYYMMDD 203 CCYYMMDDHHMM
Segmentstatus: Mandatory						
This segment is used to specify the date of the order response. Identification of the 'Document/ message date/time' (code value 137) is mandatory in the message.						
Example: DTM+137:20181020:102' Date of the order confirmation is the 20th of October 2018.						

Max. Occ. = Maximum Occurrence, St = Status, * = Restricted Codes
Status: M=Mandatory, R=Required, O=Optional, D=Dependent, A=Advised, N=Not used

Segment Layout

Heading section

No. Seg	St	Max. Occ.				
6	DTM	O 1	Date/time/period To specify date, and/or time, or period.			
Business Term	DE	EDIFACT	Format	St	*	Description
	C507	Date/time/period		M		
	2005	Date or time or period function code qualifier	an..3	M	*	2 Delivery date/ time, requested
Delivery date, requested	2380	Date or time or period value	an..35	R		
	2379	Date or time or period format code	an..3	R		102 CCYYMMDD 203 CCYYMMDDHHMM 718 CCYYMMDD- CCYYMMDD Format of period to be given in actual message without hyphen.
Segmentstatus: Optional						
This segment is used by the supplier to specify an amendment of the delivery date requested by the buyer.						
Example: DTM+2:20181028:102' Requested delivery date now is the 28th of October 2018.						

Max. Occ. = Maximum Occurrence, St = Status, * = Restricted Codes
 Status: M=Mandatory, R=Required, O=Optional, D=Dependent, A=Advised, N=Not used

Segment Layout

Heading section

No. Seg	St	Max. Occ.				
7	DTM	O 1	Date/time/period To specify date, and/or time, or period.			
Business Term	DE	EDIFACT	Format	St	*	Description
	C507	Date/time/period		M		
	2005	Date or time or period function code qualifier	an..3	M	*	64 Delivery date/ time, earliest
Delivery date, earliest	2380	Date or time or period value	an..35	R		
	2379	Date or time or period format code	an..3	R		102 CCYYMMDD 203 CCYYMMDDHHMM
Segmentstatus: Optional						
This segment is used to specify, where required, requested dates concerning the delivery of goods.						
Note to DE 2005: The use of this codevalue excludes the use of codevalues 2, 69 and 200.						
Example: DTM+64:201810230800:203'						
The earliest delivery date/time is the 23th of October 2018 at 8.00 a.m.						

Max. Occ. = Maximum Occurrence, St = Status, * = Restricted Codes
 Status: M=Mandatory, R=Required, O=Optional, D=Dependent, A=Advised, N=Not used

Segment Layout

Heading section

No. Seg	St	Max. Occ.				
8	DTM	O 1	Date/time/period To specify date, and/or time, or period.			
Business Term	DE	EDIFACT	Format	St	*	Description
	C507	Date/time/period		M		
	2005	Date or time or period function code qualifier	an..3	M	*	63 Delivery date/ time, latest
Delivery date, latest	2380	Date or time or period value	an..35	R		
	2379	Date or time or period format code	an..3	R		102 CCYYMMDD 203 CCYYMMDDHHMM
Segmentstatus: Optional						
This segment is used to specify, where required, requested dates concerning the delivery of goods.						
Note to DE 2005: The use of this codevalue excludes the use of codevalues 2, 69 and 200.						
Example: DTM+63:201810291500:203'						
The latest delivery date/time is the 29th of October 2018 at 3.00 p.m.						

Max. Occ. = Maximum Occurrence, St = Status, * = Restricted Codes
 Status: M=Mandatory, R=Required, O=Optional, D=Dependent, A=Advised, N=Not used

Segment Layout

Heading section

No. Seg	St	Max. Occ.				
9	DTM	D 1	Date/time/period To specify date, and/or time, or period.			
Business Term	DE	EDIFACT	Format	St	*	Description
	C507	Date/time/period		M		
	2005	Date or time or period function code qualifier	an..3	M	*	61 Cancel if not delivered by this date
Cancellation if not delivered	2380	Date or time or period value	an..35	R		
	2379	Date or time or period format code	an..3	R		102 CCYYMMDD 203 CCYYMMDDHHMM
Segmentstatus: Cancellation of order, if not delivered until the date requested.						
This segment is used to specify, where required, requested dates concerning the delivery of goods.						
Example: DTM+61:201810230800:203' The example request the cancellation if not delivered until the 23th of October 2018 at 8.00 a.m.						

Max. Occ. = Maximum Occurrence, St = Status, * = Restricted Codes
Status: M=Mandatory, R=Required, O=Optional, D=Dependent, A=Advised, N=Not used

Segment Layout

Heading section

No. Seg	St	Max. Occ.				
10	DTM	O 1	Date/time/period To specify date, and/or time, or period.			
Business Term	DE	EDIFACT	Format	St	*	Description
	C507	Date/time/period		M		
	2005	Date or time or period function code qualifier	an..3	M	*	11 Despatch date and/or time
Date of delivery	2380	Date or time or period value	an..35	R		
	2379	Date or time or period format code	an..3	R		102 CCYYMMDD 203 CCYYMMDDHHMM 718 CCYYMMDD- CCYYMMDD Format of period to be given in actual message without hyphen.
Segmentstatus: Optional						
This segment is used by the supplier to specify the date of delivery.						
Example: DTM+11:20181028:102' Date of delivery is the 28th of October 2018.						

Max. Occ. = Maximum Occurrence, St = Status, * = Restricted Codes
 Status: M=Mandatory, R=Required, O=Optional, D=Dependent, A=Advised, N=Not used

Segment Layout

Heading section

No. Seg	St	Max. Occ.				
11	DTM	O 1	Date/time/period To specify date, and/or time, or period.			
Business Term	DE	EDIFACT	Format	St	*	Description
	C507	Date/time/period		M		
	2005	Date or time or period function code qualifier	an..3	M	*	67 Delivery date/ time, current schedule
Schedule, (Header section)	2380	Date or time or period value	an..35	R		
	2379	Date or time or period format code	an..3	R		102 CCYYMMDD 203 CCYYMMDDHHMM 602 CCYY 610 CCYYMM 718 CCYYMMDD- CCYYMMDD Format of period to be given in actual message without hyphen.
Segmentstatus: Optional						
This segment is used when the item is delivered according to the agreed schedule.						
Example: DTM+67:20181028:102' Delivery date / time, current schedule is the 28th of October 2018.						

Max. Occ. = Maximum Occurrence, St = Status, * = Restricted Codes
Status: M=Mandatory, R=Required, O=Optional, D=Dependent, A=Advised, N=Not used

Segment Layout

Heading section

No. Seg	St	Max. Occ.				
12	ALI	O 1	Additional information			
To indicate that special conditions due to the origin, customs preference, fiscal or commercial factors are applicable.						
Business Term	DE	EDIFACT	Format	St	*	Description
	3239	Country of origin name code	an..3	N		
	9213	Duty regime type code	an..3	N		
Partial Order, Status	4183	Special condition code	an..3	R		X1 No back orders when partial delivery (GS1 Temporary Code) X2 Back orders accepted when partial delivery (GS1 Temporary Code) 144 Deliver full order
Segmentstatus: Optional						
This segment is only used, to identify the status of partial order.						
This indication is valid for all articles of the entire order and can be overwritten in the detail-section.						
Example: ALI+++X2' Partial order allowed.						

Max. Occ. = Maximum Occurrence, St = Status, * = Restricted Codes
 Status: M=Mandatory, R=Required, O=Optional, D=Dependent, A=Advised, N=Not used

Segment Layout

Heading section

No. Seg	St	Max. Occ.				
13	SG1	D 1	RFF-DTM			
	RFF	M 1	Reference			
To specify a reference.						
Business Term	DE	EDIFACT	Format	St	*	Description
	C506	Reference		M		
	1153	Reference code qualifier	an..3	M	*	ON Order number (buyer)
Order number	1154	Reference identifier	an..70	R		
<p>Segmentstatus: Depending</p> <p>This segment must be used to provide the order number related to the order response. In case of CRP orders this information is not available, the segment group is omitted.</p> <p>Example: RFF+ON:4711'</p> <p>The message references to the order number 4711.</p>						

Max. Occ. = Maximum Occurrence, St = Status, * = Restricted Codes
 Status: M=Mandatory, R=Required, O=Optional, D=Dependent, A=Advised, N=Not used

Segment Layout

Heading section

No. Seg	St	Max. Occ.				
14	SG1	D 1	RFF-DTM			
	DTM	O 5	Date/time/period To specify date, and/or time, or period.			
Business Term	DE	EDIFACT	Format	St	*	Description
	C507	Date/time/period		M		
	2005	Date or time or period function code qualifier	an..3	M	*	171 Reference date/ time
Ordering date	2380	Date or time or period value	an..35	R		
	2379	Date or time or period format code	an..3	R		102 CCYYMMDD
Segmentstatus: Optional						
This segment is used to specify any dates related to the references given in the previous RFF segment.						
Example: DTM+171:20180301:102' Buyers order is dated the 01th of March 2018.						

Max. Occ. = Maximum Occurrence, St = Status, * = Restricted Codes
Status: M=Mandatory, R=Required, O=Optional, D=Dependent, A=Advised, N=Not used

Segment Layout

Heading section

No. Seg	St	Max. Occ.				
15	SG1	O 1	RFF-DTM			
	RFF	M 1	Reference			
To specify a reference.						
Business Term	DE	EDIFACT	Format	St	*	Description
	C506	Reference		M		
	1153	Reference code qualifier	an..3	M	*	CR Customer reference number
Order reference	1154	Reference identifier	an..70	R		
<p>Segmentstatus: Optional</p> <p>This RFF segment is used to indicate a order reference number relevant for the entire order response.</p> <p>This indication is valid for all articles of the entire order response and can be overwritten in the detail-section.</p> <p>Example: RFF+CR:4711 ' The order response is based on order reference no. 4711.</p>						

Max. Occ. = Maximum Occurrence, St = Status, * = Restricted Codes
 Status: M=Mandatory, R=Required, O=Optional, D=Dependent, A=Advised, N=Not used

Segment Layout

Heading section

No.	Seg	St	Max. Occ.			
16	SG1	O	1	RFF-DTM		
	RFF	M	1	Reference		
To specify a reference.						
Business Term	DE	EDIFACT	Format	St	*	Description
	C506	Reference		M		
	1153	Reference code qualifier	an..3	M	*	SS Seller's reference number
Sellers reference number	1154	Reference identifier	an..70	R		
Segmentstatus: Optional						
This RFF segment is used to indicate a sellers reference number relevant for the entire order response.						
This indication is valid for all articles of the entire order response and can be overwritten in the detail-section.						
Example: RFF+SS:4711'						
The order response is based on sellers reference no. 4711.						

Max. Occ. = Maximum Occurrence, St = Status, * = Restricted Codes
 Status: M=Mandatory, R=Required, O=Optional, D=Dependent, A=Advised, N=Not used

Segment Layout

Heading section

No. Seg	St	Max. Occ.				
17	SG1	O 1	RFF-DTM			
	RFF	M 1	Reference			
To specify a reference.						
Business Term	DE	EDIFACT	Format	St	*	Description
	C506	Reference		M		
	1153	Reference code qualifier	an..3	M	*	VN Order number (supplier)
Order number supplier	1154	Reference identifier	an..70	R		
Segmentstatus: Optional						
This RFF segment is used to indicate a order number of the supplier relevant for the entire order response.						
Example: RFF+VN:4711'						
The order response is based on order number of the supplier no. 4711.						

Max. Occ. = Maximum Occurrence, St = Status, * = Restricted Codes
 Status: M=Mandatory, R=Required, O=Optional, D=Dependent, A=Advised, N=Not used

Segment Layout

Heading section

No. Seg	St	Max. Occ.				
18	SG1	O 1	RFF-DTM			
	RFF	M 1	Reference			
To specify a reference.						
Business Term	DE	EDIFACT	Format	St	*	Description
	C506	Reference		M		
	1153	Reference code qualifier	an..3	M	*	PD Promotion deal number
Promotion deal number	1154	Reference identifier	an..70	R		
Segmentstatus: Optional						
This segment can be used to provide the promotion deal number of the orders related to the order response.						
This indication is valid for all articles of the entire order response and can be overwritten in the detail-section.						
Example: RFF+PD:4713'						
The message references to the promotion deal number 4713.						

Max. Occ. = Maximum Occurrence, St = Status, * = Restricted Codes
 Status: M=Mandatory, R=Required, O=Optional, D=Dependent, A=Advised, N=Not used

Segment Layout

Heading section

No. Seg	St	Max. Occ.				
19	SG1	O 1	RFF-DTM			
	RFF	M 1	Reference			
To specify a reference.						
Business Term	DE	EDIFACT	Format	St	*	Description
	C506	Reference		M		
	1153	Reference code qualifier	an..3	M	*	AXO Product certification number (Old code value: XC1)
ECO controlling agency	1154	Reference identifier	an..70	R		
Segmentstatus: Optional						
This segment services the requirements of EC 834/2007.						
Note: SG1 may be repeated max. 10 times.						
Example: RFF+AXO:AT-N-01-BIO'						
The message contains only BIO products. All of them are certified by the control agency AT-N-01-BIO, as long as no other information is given at line level.						

Max. Occ. = Maximum Occurrence, St = Status, * = Restricted Codes
 Status: M=Mandatory, R=Required, O=Optional, D=Dependent, A=Advised, N=Not used

Segment Layout

Heading section

No. Seg	St	Max. Occ.				
20	SG3	R 1	NAD-LOC-FII-SG4-SG6			
	NAD	M 1	Name and address			
To specify the name/address and their related function, either by C082 only and/or unstructured by C058 or structured by C080 thru 3207.						
Business Term	DE	EDIFACT	Format	St	*	Description
	3035	Party function code qualifier	an..3	M	*	SU Supplier
	C082	Party identification details		A		
Identification of supplier	3039	Party identifier	an..35	M		Global Location Number (GLN) - Format n13
	1131	Code list identification code	an..17	N		
	3055	Code list responsible agency code	an..3	R	*	9 GS1
	C058	Name and address		O		This composite may only be used to fulfill the requirements of directive 2003/58/EG, article 4. If applicable the message sender gets the possibility to give the relevant statements at this place. If C058 ist not sufficient, more declaration can be given in following RFF+GN... segments.
	3124	Name and address description	an..35	M		
	3124	Name and address description	an..35	O		
	3124	Name and address description	an..35	O		
	3124	Name and address description	an..35	O		
	3124	Name and address description	an..35	O		
Segmentstatus: Mandatory						
Within EANCOM it is mandatory to identify the supplier/manufacturer by Global Location Number (GLN).						
Example: NAD+SU+4012345000009::9+ABC123:X:X:X:X' The supplier/manufacturer is identified by Global Location Number (GLN) 4012345000009.						

Max. Occ. = Maximum Occurrence, St = Status, * = Restricted Codes
 Status: M=Mandatory, R=Required, O=Optional, D=Dependent, A=Advised, N=Not used

Segment Layout

Heading section

No. Seg	St	Max. Occ.				
21	SG3	R 1	NAD-LOC-FII-SG4-SG6			
	SG4	D 1	RFF			
	RFF	M 1	Reference			
To specify a reference.						
Business Term	DE	EDIFACT	Format	St	*	Description
	C506	Reference		M		
	1153	Reference code qualifier	an..3	M	*	GN Government reference number
Statements on business letters	1154	Reference identifier	an..70	R		
Segmentstatus: Depending						
This RFF segment may only be used if the preceeding NAD has not enough space to fulfill the requirements of directive 2003/58/EG, article 4.						
Example: RFF+GN:HRB-471111'						
German statements on business letters: HRB-471111						

Max. Occ. = Maximum Occurrence, St = Status, * = Restricted Codes
 Status: M=Mandatory, R=Required, O=Optional, D=Dependent, A=Advised, N=Not used

Segment Layout

Heading section

No. Seg	St	Max. Occ.				
SG3	R	1	NAD-LOC-FII-SG4-SG6			
SG4	O	1	RFF			
22 RFF	M	1	Reference			
To specify a reference.						
Business Term	DE	EDIFACT	Format	St	*	Description
	C506	Reference		M		
	1153	Reference code qualifier	an..3	M	*	VA VAT registration number
Supplier/issuer of invoice VAT registration number	1154	Reference identifier	an..70	R		
Segmentstatus: Optional						
The RFF segment following the NAD segment canspecify the tax number.						
Example: RFF+VA:DE101010'						
The VAT registration number is DE101010.						

Max. Occ. = Maximum Occurrence, St = Status, * = Restricted Codes
 Status: M=Mandatory, R=Required, O=Optional, D=Dependent, A=Advised, N=Not used

Segment Layout

Heading section

No. Seg	St	Max. Occ.				
23	SG3	R 1	NAD-LOC-FII-SG4-SG6			
	SG4	O 1	RFF			
	RFF	M 1	Reference			
To specify a reference.						
Business Term	DE	EDIFACT	Format	St	*	Description
	C506	Reference		M		
	1153	Reference code qualifier	an..3	M	*	YC1 Additional party identification (GS1 Temporary Code)
Additional party identification (supplier)	1154	Reference identifier	an..70	R		
<p>Segmentstatus: Optional</p> <p>This segment is used to provide reference numbers concerning the partners identified in preceding NAD segment. The use of this segment needs to be mutually agreed between the trading partners.</p> <p>If no functional or organisational differences are necessary within one company only the GLN is used for communication purposes, if applicable the receiver links within the inhouse system. Additional identifications should be agreed only in those cases when different functional entities need to be distinguished at one location.</p> <p>Example: RFF+YC1:12345' The additional party identification (supplier) is 12345.</p>						

Max. Occ. = Maximum Occurrence, St = Status, * = Restricted Codes
 Status: M=Mandatory, R=Required, O=Optional, D=Dependent, A=Advised, N=Not used

Segment Layout

Heading section

No. Seg	St	Max. Occ.				
24	SG3	R 1	NAD-LOC-FII-SG4-SG6			
	NAD	M 1	Name and address			
To specify the name/address and their related function, either by C082 only and/or unstructured by C058 or structured by C080 thru 3207.						
Business Term	DE	EDIFACT	Format	St	*	Description
	3035	Party function code qualifier	an..3	M	*	BY Buyer
	C082	Party identification details		A		
Identification of buyer/ invoicee	3039	Party identifier	an..35	M		Global Location Number (GLN) - Format n13
	1131	Code list identification code	an..17	N		
	3055	Code list responsible agency code	an..3	R	*	9 GS1
	C058	Name and address		O		This composite may only be used to fulfill the requirements of directive 2003/58/EG, article 4. If applicable the message sender gets the possibility to give the relevant statements at this place. If C058 ist not sufficient, more declaration can be given in following RFF+GN... segments.
	3124	Name and address description	an..35	M		
	3124	Name and address description	an..35	O		
	3124	Name and address description	an..35	O		
	3124	Name and address description	an..35	O		
	3124	Name and address description	an..35	O		
Segmentstatus: Mandatory						
Within EANCOM it is mandatory to identify the buyer/invoicee by Global Location Number (GLN).						
Example: NAD+BY+4398765000004::9+X:X:X:X'						
The order is generated by a buyer with the Global Location Number (GLN) 4398765000004.						

Max. Occ. = Maximum Occurrence, St = Status, * = Restricted Codes
Status: M=Mandatory, R=Required, O=Optional, D=Dependent, A=Advised, N=Not used

Segment Layout

Heading section

No. Seg	St	Max. Occ.				
SG3	R	1	NAD-LOC-FII-SG4-SG6			
SG4	D	1	RFF			
25 RFF	M	1	Reference			
To specify a reference.						
Business Term	DE	EDIFACT	Format	St	*	Description
	C506	Reference		M		
	1153	Reference code qualifier	an..3	M	*	GN Government reference number
Statements on business letters	1154	Reference identifier	an..70	R		
Segmentstatus: Depending						
This RFF segment may only be used if the preceeding NAD has not enough space to fulfill the requirements of directive 2003/58/EG, article 4.						
Example: RFF+GN:HRB-471111'						
German statements on business letters: HRB-471111						

Max. Occ. = Maximum Occurrence, St = Status, * = Restricted Codes
 Status: M=Mandatory, R=Required, O=Optional, D=Dependent, A=Advised, N=Not used

Segment Layout

Heading section

No. Seg	St	Max. Occ.				
SG3	R	1	NAD-LOC-FII-SG4-SG6			
SG4	O	1	RFF			
26 RFF	M	1	Reference			
To specify a reference.						
Business Term	DE	EDIFACT	Format	St	*	Description
	C506	Reference		M		
	1153	Reference code qualifier	an..3	M	*	IT Internal customer number
Internal customer number in suppliers system	1154	Reference identifier	an..70	R		
<p>Segmentstatus: Optional</p> <p>This segment is used to provide the reference number which is stored as customer number of suppliers system.</p> <p>If no functional or organisational differences are necessary within one company only the GLN is used for communication purposes, if applicable the receiver links within the inhouse system. Additional identifications should be agreed only in those cases when different functional entities need to be distinguished at one location.</p> <p>Example: RFF+IT:22369' The internal customer number in suppliers system is 22369.</p>						

Max. Occ. = Maximum Occurrence, St = Status, * = Restricted Codes
 Status: M=Mandatory, R=Required, O=Optional, D=Dependent, A=Advised, N=Not used

Segment Layout

Heading section

No. Seg	St	Max. Occ.				
SG3	R	1	NAD-LOC-FII-SG4-SG6			
SG4	O	1	RFF			
27 RFF	M	1	Reference			
To specify a reference.						
Business Term	DE	EDIFACT	Format	St	*	Description
	C506	Reference		M		
	1153	Reference code qualifier	an..3	M	*	YC1 Additional party identification (GS1 Temporary Code)
Additional party identification (Buyer)	1154	Reference identifier	an..70	R		
Segmentstatus: Optional						
<p>This segment is used to provide reference numbers concerning the partners identified in preceding NAD segment. The use of this segment needs to be mutually agreed between the trading partners.</p> <p>If no functional or organisational differences are necessary within one company only the GLN is used for communication purposes, if applicable the receiver links within the inhouse system. Additional identifications should be agreed only in those cases when different functional entities need to be distinguished at one location.</p> <p>Example: RFF+YC1:22369' The additional party identification (customer) is 22369.</p>						

Max. Occ. = Maximum Occurrence, St = Status, * = Restricted Codes
 Status: M=Mandatory, R=Required, O=Optional, D=Dependent, A=Advised, N=Not used

Segment Layout

Heading section

No. Seg	St	Max. Occ.				
SG3	R	1	NAD-LOC-FII-SG4-SG6			
SG6	O	5	CTA-COM			
28 CTA	M	1	Contact information To identify a person or a department to whom communication should be directed.			
Business Term	DE	EDIFACT	Format	St	*	Description
	3139	Contact function code	an..3	R		PD Purchasing contact OC Order contact
	C056	Department or employee details		O		
Contact person or department	3413	Department or employee name code	an..17	R		
Segmentstatus: Optional						
For possible checkback this segment can provide a person to turn to.						
Example: CTA+PD+Claus Früh'						
Buyers contact person is Claus Früh.						

Max. Occ. = Maximum Occurrence, St = Status, * = Restricted Codes
 Status: M=Mandatory, R=Required, O=Optional, D=Dependent, A=Advised, N=Not used

Segment Layout

Heading section

No. Seg	St	Max. Occ.				
29	SG3	R 1	NAD-LOC-FII-SG4-SG6			
	SG6	O 5	CTA-COM			
	COM	O 5	Communication contact			
To identify a communication number of a department or a person to whom communication should be directed.						
Business Term	DE	EDIFACT	Format	St	*	Description
	C076	Communication contact		M		
Communication number	3148	Communication address identifier	an..51	M		
	3155	Communication address code qualifier	an..3	M		EM Electronic mail FX Fax TE Telephone XF X.400
Segmentstatus: Optional						
Communication contact of the person to turn to.						
Example: COM+kölsch@früh.de:EM'						
E-mail of Mr. Früh is kölsch@früh.de						

Max. Occ. = Maximum Occurrence, St = Status, * = Restricted Codes
 Status: M=Mandatory, R=Required, O=Optional, D=Dependent, A=Advised, N=Not used

Segment Layout

Heading section

No. Seg	St	Max. Occ.				
30	SG3	O 1	NAD-LOC-FII-SG4-SG6			
	NAD	M 1	Name and address To specify the name/address and their related function, either by C082 only and/or unstructured by C058 or structured by C080 thru 3207.			
Business Term	DE	EDIFACT	Format	St	*	Description
	3035	Party function code qualifier	an..3	M	*	IV Invoicee
	C082	Party identification details		A		
Identification of invoicee	3039	Party identifier	an..35	M		Global Location Number (GLN)- Format n13
	1131	Code list identification code	an..17	N		
	3055	Code list responsible agency code	an..3	R	*	9 GS1
Segmentstatus: Optional						
The invoicee is identified by GLN if not identical with buyer.						
Example: NAD+IV+4071615192710::9' Invoicee is identified by GLN 4071615192710.						

Max. Occ. = Maximum Occurrence, St = Status, * = Restricted Codes
Status: M=Mandatory, R=Required, O=Optional, D=Dependent, A=Advised, N=Not used

Segment Layout

Heading section

No. Seg	St	Max. Occ.				
31	SG3	R 1	NAD-LOC-FII-SG4-SG6			
	NAD	M 1	Name and address			
To specify the name/address and their related function, either by C082 only and/or unstructured by C058 or structured by C080 thru 3207.						
Business Term	DE	EDIFACT	Format	St	*	Description
	3035	Party function code qualifier	an..3	M	*	DP Delivery party
	C082	Party identification details		D		
GLN of the receiver of goods/services	3039	Party identifier	an..35	M		Global Location Number (GLN) - Format n13
	1131	Code list identification code	an..17	N		
	3055	Code list responsible agency code	an..3	R	*	9 GS1
	C058	Name and address		N		
	3124	Name and address description	an..35			
	C080	Party name		D		
Name 1 of the receiver	3036	Party name	an..35	M		
Name 2 of the receiver	3036	Party name	an..35	D		
Name 3 of the receiver	3036	Party name	an..35	D		
	C059	Street		D		
Street and number of receiver	3042	Street and number or post office box identifier	an..35	M		
Place of receiver - name of a city (town, village) for addressing purposes.	3164	City name	an..35	D		
	C819	Country sub-entity details		D		
	3229	Country sub-entity name code	an..9	O		Identification of the name of sub-entities (state, province) defined by appropriate governmental agencies
Postcode of receiver	3251	Postal identification code	an..17	D		
Country of receiver, coded	3207	Country name code	an..3	D		
Segmentstatus: Mandatory						
This NAD segment always identifies the first delivery place.						
The NAD segment is used to specify names, address and function of a partner, either only by data element group C082 and/or in structure form by data element group C080 to 3707.						
DE 3039: Use of GLN, the specification of the Global Location Number is sufficient.						

Max. Occ. = Maximum Occurrence, St = Status, * = Restricted Codes
 Status: M=Mandatory, R=Required, O=Optional, D=Dependent, A=Advised, N=Not used

Segment Layout

Heading section

For receivers, who do not have GLN, the address is indicated as clear text. The group C082 remains empty in this case.

If the delivery party is not known (e.g. pick up by third party), the GLN of the buyer is indicated in DE 3039.

Example: NAD+DP+4399899175941::9++EDI-LAND:Herr Laufen:Garage+Bussardweg 5+Leopardshöhle++3818+DE'

The receiver is identified by Global Location Number (GLN) 4399899175941. An address in clear text is only allowed in exceptional cases.

Segment Layout

Heading section

No. Seg	St	Max. Occ.	
SG3	R	1	NAD-LOC-FII-SG4-SG6
SG4	O	1	RFF
32 RFF	M	1	Reference

To specify a reference.

Business Term	DE	EDIFACT	Format	St	*	Description
	C506	Reference		M		
	1153	Reference code qualifier	an..3	M	*	YC1 Additional party identification (GS1 Temporary Code)
Internal identification for the receiver	1154	Reference identifier	an..70	R		

Segmentstatus: Optional

This segment is used to provide reference numbers concerning the partners identified in preceding NAD segment. The use of this segment needs to be mutually agreed between the trading partners.

If no functional or organisational differences are necessary within one company only the GLN is used for communication purposes, if applicable the receiver links within the inhouse system. Additional identifications should be agreed only in those cases when different functional entities need to be distinguished at one location.

Example: RFF+YC1:45698'

The internal identification for the receiver is 45698.

Max. Occ. = Maximum Occurrence, St = Status, * = Restricted Codes
 Status: M=Mandatory, R=Required, O=Optional, D=Dependent, A=Advised, N=Not used

Segment Layout

Heading section

No. Seg	St	Max. Occ.				
SG3	R	1	NAD-LOC-FII-SG4-SG6			
SG4	O	1	RFF			
33	RFF	M	1	Reference		
To specify a reference.						
Business Term	DE	EDIFACT	Format	St	*	Description
	C506	Reference		M		
	1153	Reference code qualifier	an..3	M	*	IT Internal customer number
Customer Number within the supplier system	1154	Reference identifier	an..70	R		
Segmentstatus: Optional						
This segment is used to provide the reference number which is stored as customer number of suppliers system.						
If no functional or organisational differences are necessary within one company only the GLN is used for communication purposes, if applicable the receiver links within the inhouse system. Additional identifications should be agreed only in those cases when different functional entities need to be distinguished at one location.						
Example: RFF+IT:313131'						
The internal customer number in the supplier system for the receiver is 313131.						

Max. Occ. = Maximum Occurrence, St = Status, * = Restricted Codes
 Status: M=Mandatory, R=Required, O=Optional, D=Dependent, A=Advised, N=Not used

Segment Layout

Heading section

No. Seg	St	Max. Occ.				
34	SG3	R 1	NAD-LOC-FII-SG4-SG6			
	SG6	O 5	CTA-COM			
	CTA	M 1	Contact information			
To identify a person or a department to whom communication should be directed.						
Business Term	DE	EDIFACT	Format	St	*	Description
	3139	Contact function code	an..3	R		PD Purchasing contact
	C056	Department or employee details		O		
Contact person or department receiver of goods/services	3413	Department or employee name code	an..17	R		
Segmentstatus: Optional						
For possible checkback this segment can provide a person to turn to.						
Example: CTA+PD+Claus Früh'						
Contact person is Claus Früh.						

Max. Occ. = Maximum Occurrence, St = Status, * = Restricted Codes
 Status: M=Mandatory, R=Required, O=Optional, D=Dependent, A=Advised, N=Not used

Segment Layout

Heading section

No. Seg	St	Max. Occ.				
35	SG3	R 1	NAD-LOC-FII-SG4-SG6			
	SG6	O 5	CTA-COM			
	COM	O 5	Communication contact			
To identify a communication number of a department or a person to whom communication should be directed.						
Business Term	DE	EDIFACT	Format	St	*	Description
	C076	Communication contact		M		
Communication number receiver of goods/services	3148	Communication address identifier	an..51	M		
	3155	Communication address code qualifier	an..3	M		EM Electronic mail FX Fax TE Telephone XF X.400
Segmentstatus: Optional						
Communication contact of the person to turn to.						
Example: COM+kölsch@früh.de:EM'						
E-mail of Mr. Früh is kölsch@früh.de						

Max. Occ. = Maximum Occurrence, St = Status, * = Restricted Codes

Status: M=Mandatory, R=Required, O=Optional, D=Dependent, A=Advised, N=Not used

Segment Layout

Heading section

No. Seg	St	Max. Occ.				
36	SG3	O 1	NAD-LOC-FII-SG4-SG6			
	NAD	M 1	Name and address			
To specify the name/address and their related function, either by C082 only and/or unstructured by C058 or structured by C080 thru 3207.						
Business Term	DE	EDIFACT	Format	St	*	Description
	3035	Party function code qualifier	an..3	M	*	PW Despatch party
	C082	Party identification details		D		
Pick up place identification	3039	Party identifier	an..35	M		Global Location Number (GLN) - Format n13
	1131	Code list identification code	an..17	N		
	3055	Code list responsible agency code	an..3	R	*	9 GS1
	C058	Name and address		N		
	3124	Name and address description	an..35			
	C080	Party name		D		
Pick up place Name 1	3036	Party name	an..35	M		
Pick up place Name 2	3036	Party name	an..35	D		
Pick up place Name 3	3036	Party name	an..35	D		
	C059	Street		D		
Pick up place street	3042	Street and number or post office box identifier	an..35	M		
Pick up place city/town	3164	City name	an..35	D		
	C819	Country sub-entity details		D		
	3229	Country sub-entity name code	an..9	O		
Pick up place postal code	3251	Postal identification code	an..17	D		
	3207	Country name code	an..3	D		ISO 3166 two alpha code
Segmentstatus: Optional						
The existence of this segment indicates the pick up of goods by a third party.						
The collection place is identified by Global Location Number (GLN). Party name and address in clear text may only be used, if a Global Location Number (GLN) is not (yet) available.						
Example: NAD+PW+4089876511111::9++Abholstelle-Name 1:Abholstelle-Name 2:Abholstelle-Name 3+ Maarweg 104+Köln++50825+DE' The collection place is identified by Global Location Number (GLN) 4089876511111.						

Max. Occ. = Maximum Occurrence, St = Status, * = Restricted Codes
Status: M=Mandatory, R=Required, O=Optional, D=Dependent, A=Advised, N=Not used

Segment Layout

Heading section

No. Seg	St	Max. Occ.	
SG3	O	1	NAD-LOC-FII-SG4-SG6
SG4	O	1	RFF
37 RFF	M	1	Reference

To specify a reference.

Business Term	DE	EDIFACT	Format	St	*	Description
	C506	Reference		M		
	1153	Reference code qualifier	an..3	M	*	YC1 Additional party identification (GS1 Temporary Code)
Pick up place additional identification	1154	Reference identifier	an..70	R		

Segmentstatus: Optional

The RFF segment following the NAD segment can specify a mutually agreed additional identification.

If no functional or organisational differences are necessary within one company only the GLN is used for communication purposes, if applicable the receiver links within the inhouse system. Additional identifications should be agreed only in those cases when different functional entities need to be distinguished at one location.

Example: RFF+YC1:0816'

The additional identification is 0816.

Max. Occ. = Maximum Occurrence, St = Status, * = Restricted Codes
 Status: M=Mandatory, R=Required, O=Optional, D=Dependent, A=Advised, N=Not used

Segment Layout

Heading section

No. Seg	St	Max. Occ.				
38	SG3	O 1	NAD-LOC-FII-SG4-SG6			
	NAD	M 1	Name and address			
To specify the name/address and their related function, either by C082 only and/or unstructured by C058 or structured by C080 thru 3207.						
Business Term	DE	EDIFACT	Format	St	*	Description
	3035	Party function code qualifier	an..3	M	*	UC Ultimate consignee
	C082	Party identification details		D		
GLN of the ultimate consignee	3039	Party identifier	an..35	M		Global Location Number (GLN) - Format n13
	1131	Code list identification code	an..17	N		
	3055	Code list responsible agency code	an..3	R	*	9 GS1
	C058	Name and address		N		
	3124	Name and address description	an..35			
	C080	Party name		D		
Name 1 of the ultimate consignee	3036	Party name	an..35	M		
Name 2 of the ultimate consignee	3036	Party name	an..35	D		
Name 3 of the ultimate consignee	3036	Party name	an..35	D		
	C059	Street		D		
Street of ultimate consignee	3042	Street and number or post office box identifier	an..35	M		
Place of ultimate consignee - name of a city (town, village) for addressing purposes.	3164	City name	an..35	D		
	C819	Country sub-entity details		D		
	3229	Country sub-entity name code	an..9	O		
Postcode of ultimate consignee	3251	Postal identification code	an..17	D		
	3207	Country name code	an..3	D		ISO 3166 two alpha code
Segmentstatus: Optional						
This NAD segment is used to specify name and address of the ultimate consignee. If the warehouse is the delivery party (DE 3035 = DP) and the consignment is addressed to a specific outlet, that outlet is identified as ultimate consignee.						
Use of the GLN, the specification of the Global Location Number is sufficient.						

Max. Occ. = Maximum Occurrence, St = Status, * = Restricted Codes
 Status: M=Mandatory, R=Required, O=Optional, D=Dependent, A=Advised, N=Not used

Segment Layout

Heading section

For ultimate consignees, who do not have GLN, the address is indicated as clear text. The group C082 remains empty in this case.

Example: NAD+UC+4399899175941::9++EDI-LAND:Herr Laufen:Garage+Bussardweg 5+Leopardshöhle++3818+DE'

The ultimate consignee is identified by Global Location Number (GLN) 4399899175941.
An address in clear text is only allowed in exceptional cases.

Segment Layout

Heading section

No. Seg	St	Max. Occ.				
39	SG7	D 1	TAX-MOA			
	TAX	M 1	Duty/tax/fee details			
To specify relevant duty/tax/fee information.						
Business Term	DE	EDIFACT	Format	St	*	Description
	5283	Duty or tax or fee function code qualifier	an..3	M	*	7 Tax
	C241	Duty/tax/fee type		D		
Value added tax on document level	5153	Duty or tax or fee type name code	an..3	O	*	VAT Value added tax
	1131	Code list identification code	an..17	O		
	3055	Code list responsible agency code	an..3	D		
	5152	Duty or tax or fee type name	an..35	O		
	C533	Duty/tax/fee account detail		O		
	5289	Duty or tax or fee account code	an..6	M		
	1131	Code list identification code	an..17	O		
	3055	Code list responsible agency code	an..3	D		
	5286	Duty or tax or fee assessment basis value	an..15	O		
	C243	Duty/tax/fee detail		A		
	5279	Duty or tax or fee rate code	an..7	O		
	1131	Code list identification code	an..17	O		
	3055	Code list responsible agency code	an..3	D		
	5278	Duty or tax or fee rate	an..17	R		Actual tax rate
	5273	Duty or tax or fee rate basis code	an..12	O		
	1131	Code list identification code	an..17	O		
	3055	Code list responsible agency code	an..3	D		
	5305	Duty or tax or fee category code	an..3	R		E Exempt from tax S Standard rate O Services outside scope of tax

Segmentstatus: Depending, Mandatory if not indicated in the complete detail section.

The main tax rate is indicated here in the heading section of the message. Should the occasion arise different tax rates are indicated on detail level.

Note to DE 5278 and 5305: if the business volume is free of tax, DE 5278 must contain 0 (zero).

Max. Occ. = Maximum Occurrence, St = Status, * = Restricted Codes

Status: M=Mandatory, R=Required, O=Optional, D=Dependent, A=Advised, N=Not used

Segment Layout

Heading section

Example: TAX+7+VAT+123ABC++:::19+S'

The dominant tax rate of the document is 19%.

Segment Layout

Heading section

No. Seg	St	Max. Occ.				
40	SG8	D 1	CUX-DTM			
	CUX	M 1	Currencies			
To specify currencies used in the transaction and relevant details for the rate of exchange.						
Business Term	DE	EDIFACT	Format	St	*	Description
	C504	Currency details		R		
	6347	Currency usage code qualifier	an..3	M	*	2 Reference currency
Currency code	6345	Currency identification code	an..3	R		ISO 4217 3-Alpha Code
	6343	Currency type code qualifier	an..3	R	*	9 Order currency
Segmentstatus: Depending						
This segment is used by the supplier to specify an amendment of the currency requested by the buyer.						
Example: CUX+2:EUR:9' Order Currency is EURO						

Max. Occ. = Maximum Occurrence, St = Status, * = Restricted Codes
 Status: M=Mandatory, R=Required, O=Optional, D=Dependent, A=Advised, N=Not used

Segment Layout

Heading section

No. Seg	St	Max. Occ.				
41	SG9	D 1	PAT-DTM-PCD-MOA			
	PAT	M 1	Payment terms basis			
To specify the payment terms basis.						
Notes:						
1. This segment will be removed effective with directory D.02B.						
Business Term	DE	EDIFACT	Format	St	*	Description
Fixdate for payment	4279	Payment terms type code qualifier	an..3	M	*	3 Fixed date
Segment group status: Depending						
This segment group is used by the supplier to specify an amendment of the payment terms requested by the buyer.						
Example: PAT+3'						
Fixdate for payment						

Max. Occ. = Maximum Occurrence, St = Status, * = Restricted Codes
 Status: M=Mandatory, R=Required, O=Optional, D=Dependent, A=Advised, N=Not used

Segment Layout

Heading section

No. Seg	St	Max. Occ.				
42	SG9	D 1	PAT-DTM-PCD-MOA			
	DTM	R 5	Date/time/period To specify date, and/or time, or period.			
Business Term	DE	EDIFACT	Format	St	*	Description
	C507	Date/time/period		M		
	2005	Date or time or period function code qualifier	an..3	M	*	209 Value date
Value date	2380	Date or time or period value	an..35	R		
	2379	Date or time or period format code	an..3	R		102 CCYYMMDD
Segmentstatus: Mandatory						
If this segment group is used the indication of value date is mandatory.						
Example: DTM+209:20181028:102'						
Value date is the 28th of October 2018.						

Max. Occ. = Maximum Occurrence, St = Status, * = Restricted Codes
 Status: M=Mandatory, R=Required, O=Optional, D=Dependent, A=Advised, N=Not used

Segment Layout

Heading section

No. Seg	St	Max. Occ.				
43	SG9	D 1	PAT-DTM-PCD-MOA			
	PAT	M 1	Payment terms basis To specify the payment terms basis.			
Notes:						
1. This segment will be removed effective with directory D.02B.						
Business Term	DE	EDIFACT	Format	St	*	Description
Payment terms	4279	Payment terms type code qualifier	an..3	M	*	7 Extended
	C110	Payment terms		O		
	4277	Payment terms description identifier	an..17	N		
	C112	Terms/time information		O		
	2475	Time reference code	an..3	M		5 Date of invoice
	2009	Terms time relation code	an..3	R		3 After reference
	2151	Period type code	an..3	R	*	D Day
Number of periods (days) for payment	2152	Period count quantity	n..3	R		
Segment group status: Depending						
This segment group is used by the supplier to specify an amendment of the extended payment date requested by the buyer.						
Example: PAT+7++5:3:D:30'						
Value: 30 days after invoice date						

Max. Occ. = Maximum Occurrence, St = Status, * = Restricted Codes
 Status: M=Mandatory, R=Required, O=Optional, D=Dependent, A=Advised, N=Not used

Segment Layout

Heading section

No. Seg	St	Max. Occ.				
44	SG10	O 1	TDT-SG11			
	TDT	M 1	Details of transport			
To specify the transport details such as mode of transport, means of transport, its conveyance reference number and the identification of the means of transport.						
Business Term	DE	EDIFACT	Format	St	*	Description
	8051	Transport stage code qualifier	an..3	M		20 Main-carriage transport
	8028	Means of transport journey identifier	an..17	N		
	C220	Mode of transport		N		
	8067	Transport mode name code	an..3	R		
	C228	Transport means		O		
Transport means	8179	Transport means description code	an..8	D		31 Truck 48 Van 21E Flat lorry 15t (GS1 Temporary Code) All codes can be used.
	8178	Transport means description	an..17	D		
	C040	Carrier		O		
	3127	Carrier identifier	an..17	O		GLN of the carrier
	1131	Code list identification code	an..17	N		
	3055	Code list responsible agency code	an..3	R	*	9 GS1
	3128	Carrier name	an..35	O		
Segmentstatus: Optional						
This segment is used to specify transport instructions for the whole Purchase Order, such as requesting an express transport service.						
Example: TDT+20+++48+4012345123456:::9:Transport GmbH Schnelle Bücher' road parcel express: "Transport GmbH Schnelle Bücher"						

Max. Occ. = Maximum Occurrence, St = Status, * = Restricted Codes
 Status: M=Mandatory, R=Required, O=Optional, D=Dependent, A=Advised, N=Not used

Segment Layout

Heading section

No. Seg	St	Max. Occ.				
SG10	O	1	TDT-SG11			
SG11	O	10	LOC-DTM			
45 LOC	M	1	Place/location identification To identify a place or a location and/or related locations.			
Business Term	DE	EDIFACT	Format	St	*	Description
	3227	Location function code qualifier	an..3	M	*	301 Location of meter (Old code value: 17E)
	C517	Location identification		R		
	3225	Location name code	an..25	N		
	1131	Code list identification code	an..17	N		
	3055	Code list responsible agency code	an..3	R		91 Assigned by supplier or supplier's agent
International meter identification	3224	Location name	an..25	R		33-digits
Segmentstatus: Optional						
This segment group is only used to identify a meter (electricity, gas, etc.).						
Example: LOC+301+: :91:DE1235891257322H0H422598442568863'						
International meter identification						

Max. Occ. = Maximum Occurrence, St = Status, * = Restricted Codes
Status: M=Mandatory, R=Required, O=Optional, D=Dependent, A=Advised, N=Not used

Segment Layout

Detail section

No. Seg	St	Max. Occ.			
46	SG26	O 200000	LIN-PIA-IMD-MEA-QTY-ALI-DTM-MOA-GIN-QVR-FTX-SG30-SG31-SG32-SG35-SG36-SG37-SG41-SG47		
	LIN	M 1	Line item To identify a line item and configuration.		
Business Term	DE	EDIFACT	Format	St	* Description
Line item number	1082	Line item identifier	an..6	R	Application generated line item number
	1229	Action request/ notification description code	an..3	R	1 Added 2 Deleted 3 Changed 5 Accepted without amendment 7 Not accepted 10 Not found 24 Accepted with amendment, no confirmation required Important note: In the media sectors only the use of code values 5, 7 and 24 is allowed. Important note: In the textile industry only the use of code values 1, 3, 5, and 7 is allowed. DE 1229: Action Request, coded, is the critical DE in this segment. The following code value definitions apply: 2 = Deleted : The information is to be or has been deleted. 3 = Changed : The supplier accepts to supply the line item in a purchase order or purchase order change request, but requires one or more changes to the terms set out in the referenced message, as indicated by the data in, and following, the LIN segment. The buyer must acknowledge these requirements by sending a new purchase order or purchase order change request. 5 = Accepted : The supplier accepts to supply the line item in a purchase order or purchase order change request. Though it is not necessary to re-transmit

Max. Occ. = Maximum Occurrence, St = Status, * = Restricted Codes
 Status: M=Mandatory, R=Required, O=Optional, D=Dependent, A=Advised, N=Not used

Segment Layout

Detail section

Business Term	DE	EDIFACT	Format	St	*	Description
						unamended line items or cancellations, this may be done for confirmation. 7 = Not Accepted : The supplier declines to supply the line item in a purchase order or purchase order change request. 10 = Not Found : This line item is not found in the referenced message. 24 = Accepted with amendment, no confirmation required : Accepted with changes which require no confirmation.
	C212	Item number identification		D		
GTIN Global Trade Item Number	7140	Item identifier	an..35	R		Format n..14
	7143	Item type identification code	an..3	R	*	SRV GS1 Global Trade Item Number

Segmentstatus: Mandatory

The LIN-segment is used to specify the item being ordered.

In this segment the GTIN is indicated as item identification.

The detail section always starts with the LIN-segment.

Example: `LIN+1+5+4000004000035:SRV'`

The ordered item with the item number 1 is identified with the GTIN 4000004000035 was accepted without amendment.

Max. Occ. = Maximum Occurrence, St = Status, * = Restricted Codes
 Status: M=Mandatory, R=Required, O=Optional, D=Dependent, A=Advised, N=Not used

Segment Layout

Detail section

No. Seg	St	Max. Occ.				
47	SG26	O 200000	LIN-PIA-IMD-MEA-QTY-ALI-DTM-MOA-GIN-QVR-FTX-SG30-SG31-SG32-SG35-SG36-SG37-SG41-SG47			
	PIA	D 1	Additional product id To specify additional or substitutional item identification codes.			
Business Term	DE	EDIFACT	Format	St	*	Description
	4347	Product identifier code qualifier	an..3	M	*	5 Product identification
	C212	Item number identification		M		
Supplier's article number	7140	Item identifier	an..35	R		
	7143	Item type identification code	an..3	R	*	SA Supplier's article number
	1131	Code list identification code	an..17	N		
	3055	Code list responsible agency code	an..3	R	*	91 Assigned by supplier or supplier's agent
<p>Segmentstatus: Optional, if LIN segment does not provide a GTIN, otherwise segment is not used.</p> <p>This segment is only used, if LIN segment does not provide a GTIN. Then it must follow the LIN segment immediately. In this case LIN segment (mandatory) only provides the line item number. Identification of the article is done by use of the suppliers article number in this PIA segment, DE 4347 is filled with "5" for primary identification.</p> <p>Book: ISBN13 or the suppliers article number can be used as primary identification. The application of both numbering systems at the same time is not allowed, if DE 4347 filled with "5" for primary identification is used.</p> <p>Example: PIA+5+ABC5343:SA: :91' Only if LIN does not provide a GTIN: Item identification in PIA</p>						

Max. Occ. = Maximum Occurrence, St = Status, * = Restricted Codes
 Status: M=Mandatory, R=Required, O=Optional, D=Dependent, A=Advised, N=Not used

Segment Layout

Detail section

No. Seg	St	Max. Occ.				
48	SG26	O 200000	LIN-PIA-IMD-MEA-QTY-ALI-DTM-MOA-GIN-QVR-FTX-SG30-SG31-SG32-SG35-SG36-SG37-SG41-SG47			
	PIA	D 1	Additional product id To specify additional or substitutional item identification codes.			
Business Term	DE	EDIFACT	Format	St	*	Description
	4347	Product identifier code qualifier	an..3	M	*	5 Product identification
	C212	Item number identification		M		
Buyers article number	7140	Item identifier	an..35	R		
	7143	Item type identification code	an..3	R	*	IN Buyer's item number
	1131	Code list identification code	an..17	N		
	3055	Code list responsible agency code	an..3	R	*	92 Assigned by buyer or buyer's agent
<p>Segmentstatus: Optional, if LIN segment does not provide a GTIN, otherwise segment is not used.</p> <p>This segment is only used, if LIN segment does not provide a GTIN. Then it must follow the LIN segment immediately. In this case LIN segment (mandatory) only provides the line item number. Identification of the article is done by use of the buyers article number in this PIA segment, DE 4347 is filled with "5" for primary identification.</p> <p>Example: PIA+5+ABC5343:IN: :92'</p> <p>Only if LIN does not provide a GTIN: Item identification in PIA</p>						

Max. Occ. = Maximum Occurrence, St = Status, * = Restricted Codes
 Status: M=Mandatory, R=Required, O=Optional, D=Dependent, A=Advised, N=Not used

Segment Layout

Detail section

No. Seg	St	Max. Occ.				
49	SG26	O 200000	LIN-PIA-IMD-MEA-QTY-ALI-DTM-MOA-GIN-QVR-FTX-SG30-SG31-SG32-SG35-SG36-SG37-SG41-SG47			
	PIA	D 1	Additional product id To specify additional or substitutional item identification codes.			
Business Term	DE	EDIFACT	Format	St	*	Description
	4347	Product identifier code qualifier	an..3	M	*	3 Substituted by
	C212	Item number identification		M		
Substitute article	7140	Item identifier	an..35	R		
	7143	Item type identification code	an..3	R	*	SRV GS1 Global Trade Item Number
	1131	Code list identification code	an..17	N		
	3055	Code list responsible agency code	an..3	R	*	9 GS1
<p>Segmentstatus: Mandatory, if the article number has been changed, otherwise segment is not used.</p> <p>This function can be used within the ORDRSP to indicate a change of the article number. The LIN segment provides the GTIN of the ordered product and the PIA segment provides the substitute article GTIN.</p> <p>Example: PIA+3+4025894315970;SRV: :9' Substitute article GTIN</p>						

Max. Occ. = Maximum Occurrence, St = Status, * = Restricted Codes
Status: M=Mandatory, R=Required, O=Optional, D=Dependent, A=Advised, N=Not used

Segment Layout

Detail section

No. Seg	St	Max. Occ.				
SG26	O	200000	LIN-PIA-IMD-MEA-QTY-ALI-DTM-MOA-GIN-QVR-FTX-SG30-SG31-SG32-SG35-SG36-SG37-SG41-SG47			
50			PIA	O	1	Additional product id To specify additional or substitutional item identification codes.
Business Term	DE	EDIFACT	Format	St	*	Description
	4347	Product identifier code qualifier	an..3	M	*	1 Additional identification
	C212	Item number identification		M		
Suppliers article number (secondary indent.)	7140	Item identifier	an..35	R		
	7143	Item type identification code	an..3	R	*	SA Supplier's article number
	1131	Code list identification code	an..17	N		
	3055	Code list responsible agency code	an..3	R	*	91 Assigned by supplier or supplier's agent
Segmentstatus: Optional						
This segment is used to advise the suppliers article number additionally to GTIN.						
Example: PIA+1+7788:SA::91'						
The product with GTIN 4000004000035 is additionally identified with suppliers article number 7788.						

Max. Occ. = Maximum Occurrence, St = Status, * = Restricted Codes
 Status: M=Mandatory, R=Required, O=Optional, D=Dependent, A=Advised, N=Not used

Segment Layout

Detail section

No. Seg	St	Max. Occ.				
51	SG26	O 200000	LIN-PIA-IMD-MEA-QTY-ALI-DTM-MOA-GIN-QVR-FTX-SG30-SG31-SG32-SG35-SG36-SG37-SG41-SG47			
	PIA	O 1	Additional product id To specify additional or substitutional item identification codes.			
Business Term	DE	EDIFACT	Format	St	*	Description
	4347	Product identifier code qualifier	an..3	M	*	1 Additional identification
	C212	Item number identification		M		
Buyers article number	7140	Item identifier	an..35	R		
	7143	Item type identification code	an..3	R	*	IN Buyer's item number
	1131	Code list identification code	an..17	N		
	3055	Code list responsible agency code	an..3	R	*	92 Assigned by buyer or buyer's agent
Segmentstatus: Optional						
This segment is used to indicate the buyers article number additionally to GTIN.						
Example: PIA+1+1234:IN::92'						
The product with GTIN 4000004000035 is additionally identified with buyers article number 1234.						

Max. Occ. = Maximum Occurrence, St = Status, * = Restricted Codes
 Status: M=Mandatory, R=Required, O=Optional, D=Dependent, A=Advised, N=Not used

Segment Layout

Detail section

No. Seg	St	Max. Occ.				
52			SG26	O	200000	LIN-PIA-IMD-MEA-QTY-ALI-DTM-MOA-GIN-QVR-FTX-SG30-SG31-SG32-SG35-SG36-SG37-SG41-SG47
			PIA	O	1	Additional product id To specify additional or substitutional item identification codes.
Business Term	DE	EDIFACT	Format	St	*	Description
	4347	Product identifier code qualifier	an..3	M	*	1 Additional identification
	C212	Item number identification		M		
Articles promotional variant	7140	Item identifier	an..35	R		Article number
	7143	Item type identification code	an..3	R	*	PV Promotional variant number
	1131	Code list identification code	an..17	N		
	3055	Code list responsible agency code	an..3	R		9 GS1 91 Assigned by supplier or supplier's agent 92 Assigned by buyer or buyer's agent
Segmentstatus: Optional						
This segment is used to mark an article as a promotional variant.						
DE 7143 = PV, promotional variant: The number supplementing the identification code of a product identifies this product as a variant of the standard product. To be used if the variant has only minimal differences and a changed of the main identification code is not justified.						
Example: PIA+1+4056786542381:PV::9' The product identified with GTIN 4000004000035 is a promotional variant.						

Max. Occ. = Maximum Occurrence, St = Status, * = Restricted Codes
Status: M=Mandatory, R=Required, O=Optional, D=Dependent, A=Advised, N=Not used

Segment Layout

Detail section

No. Seg	St	Max. Occ.				
SG26	O	200000	LIN-PIA-IMD-MEA-QTY-ALI-DTM-MOA-GIN-QVR-FTX-SG30-SG31-SG32-SG35-SG36-SG37-SG41-SG47			
53						
PIA	O	1	Additional product id To specify additional or substitutional item identification codes.			
Business Term	DE	EDIFACT	Format	St	*	Description
	4347	Product identifier code qualifier	an..3	M	*	1 Additional identification
	C212	Item number identification		M		
Class of goods	7140	Item identifier	an..35	R		
	7143	Item type identification code	an..3	R	*	GB Buyer's internal product group code
	1131	Code list identification code	an..17	N		
	3055	Code list responsible agency code	an..3	R	*	92 Assigned by buyer or buyer's agent
Segmentstatus: Optional						
This segment is used to display the class of goods.						
Example: PIA+1+4711:GB::92'						
The article belongs to the class of goods "4711"						

Max. Occ. = Maximum Occurrence, St = Status, * = Restricted Codes
 Status: M=Mandatory, R=Required, O=Optional, D=Dependent, A=Advised, N=Not used

Segment Layout

Detail section

No. Seg	St	Max. Occ.				
54			SG26	O	200000	LIN-PIA-IMD-MEA-QTY-ALI-DTM-MOA-GIN-QVR-FTX-SG30-SG31-SG32-SG35-SG36-SG37-SG41-SG47
			IMD	O	1	Item description To describe an item in either an industry or free format.
Business Term	DE	EDIFACT	Format	St	*	Description
	7077	Description format code	an..3	R	*	A Free-form long description
	C272	Item characteristic		O		
	7081	Item characteristic code	an..3	R		
	C273	Item description		R		
	7009	Item description code	an..17	N		
	1131	Code list identification code	an..17	N		
	3055	Code list responsible agency code	an..3	N		
Substitute article long description	7008	Item description	an..25	R		
	7008	Item description	an..25	N		
	3453	Language name code	an..3	O		ISO 639 2-Alpha Code
<p>Segmentstatus: Optional</p> <p>This segment can used to provide a description for the substitute article.</p> <p>Example: IMD+A++:::Rudi Rüssel::DE' Article long description: Rudi Rüssel, king of noses</p>						

Max. Occ. = Maximum Occurrence, St = Status, * = Restricted Codes
 Status: M=Mandatory, R=Required, O=Optional, D=Dependent, A=Advised, N=Not used

Segment Layout

Detail section

No. Seg	St	Max. Occ.				
55	SG26	O 200000	LIN-PIA-IMD-MEA-QTY-ALI-DTM-MOA-GIN-QVR-FTX-SG30-SG31-SG32-SG35-SG36-SG37-SG41-SG47			
	IMD	D 1	Item description To describe an item in either an industry or free format.			
Business Term	DE	EDIFACT	Format	St	*	Description
	7077	Description format code	an..3	R	*	B Code and text F Free-form
	C272	Item characteristic		O		
	7081	Item characteristic code	an..3	R	*	35 Colour alternatively: only non-numeric values SGR Size grid (GS1 Temporary Code) 98 Size
	1131	Code list identification code	an..17	N		
	3055	Code list responsible agency code	an..3	D	*	9 GS1 Must be used if DE 7081 contains an GTIN Code
	C273	Item description		A		
Colour, size (coded)	7009	Item description code	an..17	D		Codes must be agreed bilaterally.
	1131	Code list identification code	an..17	N		
	3055	Code list responsible agency code	an..3	D		92 Assigned by buyer or buyer's agent 91 Assigned by supplier or supplier's agent
Colour, size	7008	Item description	an..25	R		The length of DE 7008 is restricted to 256 characters. Bigger sizes have to be agreed bilaterally.
	7008	Item description	an..25	N		
	3453	Language name code	an..3	O		ISO 639 2-Alpha Code
<p>Segmentstatus: Depending</p> <p>This segment is used by the supplier to specify an amendment of the size or colour requested by the buyer. The colour/size name is given in clear text, e.g. red. blue, green, etc. by use of code value F in DE 7077. If additionally a colour/size identifier is provided in DE 7009 than code value B is used for DE 7077.</p> <p>Example: <code>IMD+B+SGR::9+XXL::91:::DE'</code> The item has the size XXL</p>						

Max. Occ. = Maximum Occurrence, St = Status, * = Restricted Codes
Status: M=Mandatory, R=Required, O=Optional, D=Dependent, A=Advised, N=Not used

Segment Layout

Detail section

No. Seg	St	Max. Occ.				
56	SG26	O 200000	LIN-PIA-IMD-MEA-QTY-ALI-DTM-MOA-GIN-QVR-FTX-SG30-SG31-SG32-SG35-SG36-SG37-SG41-SG47			
	MEA	D 1	Measurements To specify physical measurements, including dimension tolerances, weights and counts.			
Business Term	DE	EDIFACT	Format	St	*	Description
	6311	Measurement purpose code qualifier	an..3	M	*	PD Physical dimensions (product ordered)
	C502	Measurement details		A		
	6313	Measured attribute code	an..3	R	*	LAY Number of layers (GS1 Temporary Code)
	C174	Value/range		R		
	6411	Measurement unit code	an..3	M	*	H87 Piece (Old code value: PCE)
Number of layers per charge carrier	6314	Measurement value	an..18	O		
<p>Segmentstatus: Depending</p> <p>This segment is used by the supplier to specify an amendment of the composition of the delivery unit requested by the buyer.</p> <p>Example: MEA+PD+LAY+H87:5' Number of layers per charge carrier is "5"</p>						

Max. Occ. = Maximum Occurrence, St = Status, * = Restricted Codes
 Status: M=Mandatory, R=Required, O=Optional, D=Dependent, A=Advised, N=Not used

Segment Layout

Detail section

No. Seg	St	Max. Occ.				
57	SG26	O 200000	LIN-PIA-IMD-MEA-QTY-ALI-DTM-MOA-GIN-QVR-FTX-SG30-SG31-SG32-SG35-SG36-SG37-SG41-SG47			
	MEA	D 1	Measurements			
To specify physical measurements, including dimension tolerances, weights and counts.						
Business Term	DE	EDIFACT	Format	St	*	Description
	6311	Measurement purpose code qualifier	an..3	M	*	PD Physical dimensions (product ordered)
	C502	Measurement details		A		
	6313	Measured attribute code	an..3	A	*	ULY Number of units per layer (GS1 Temporary Code)
	C174	Value/range		R		
	6411	Measurement unit code	an..3	M	*	H87 Piece (Old code value: PCE)
Number of units per layer	6314	Measurement value	an..18	O		
Segmentstatus: Depending						
This segment is used by the supplier to specify an amendment of the composition of the delivery unit requested by the buyer.						
Example: MEA+PD+ULY+H87:5'						
Number of units per layer is "5"						

Max. Occ. = Maximum Occurrence, St = Status, * = Restricted Codes
 Status: M=Mandatory, R=Required, O=Optional, D=Dependent, A=Advised, N=Not used

Segment Layout

Detail section

No. Seg	St	Max. Occ.				
58			SG26 O 200000 LIN-PIA-IMD-MEA-QTY-ALI-DTM-MOA-GIN-QVR-FTX-SG30-SG31-SG32-SG35-SG36-SG37-SG41-SG47 MEA D 1 Measurements To specify physical measurements, including dimension tolerances, weights and counts.			
Business Term	DE	EDIFACT	Format	St	*	Description
	6311	Measurement purpose code qualifier	an..3	M	*	AAI Item weight
	C502	Measurement details		A		
	6313	Measured attribute code	an..3	A		AAA Unit net weight
	6321	Measurement significance code	an..3	N		
	6155	Non-discrete measurement name code	an..17	N		
	6154	Non-discrete measurement name	an..70	N		
	C174	Value/range		R		
	6411	Measurement unit code	an..3	M		GRM gram KGM kilogram All code values from EANCOM code list 6411 and UN/ECE Recommendation 20 code list available.
Weight of the article	6314	Measurement value	an..18	O		
Segmentstatus: Depending This segment is used by the supplier to specify an amendment of the net weights requested by the buyer. Example: MEA+AAI+AAA+GRM:6370' The weight of the article is 63.7 kg net.						

Max. Occ. = Maximum Occurrence, St = Status, * = Restricted Codes
 Status: M=Mandatory, R=Required, O=Optional, D=Dependent, A=Advised, N=Not used

Segment Layout

Detail section

No. Seg	St	Max. Occ.				
59	SG26	O 200000	LIN-PIA-IMD-MEA-QTY-ALI-DTM-MOA-GIN-QVR-FTX-SG30-SG31-SG32-SG35-SG36-SG37-SG41-SG47			
	QTY	O 1	Quantity To specify a pertinent quantity.			
Business Term	DE	EDIFACT	Format	St	*	Description
	C186	Quantity details		M		
	6063	Quantity type code qualifier	an..3	M	*	21 Ordered quantity
Originally ordered quantity	6060	Quantity	an..35	M		Note: Use only numeric values.
	6411	Measurement unit code	an..3	D		KGM kilogram LTR litre MTR metre All code values from EANCOM code list 6411 and UN/ECE Recommendation 20 code list available.
Segmentstatus: Optional						
The QTY segment is used to specify the originally ordered quantity.						
DE 6411 is only used, if the article is a variable quantity article. Default value is piece.						
Example: QTY+21:20' The originally ordered quantity amounts to 20 pieces.						

Max. Occ. = Maximum Occurrence, St = Status, * = Restricted Codes
Status: M=Mandatory, R=Required, O=Optional, D=Dependent, A=Advised, N=Not used

Segment Layout

Detail section

No. Seg	St	Max. Occ.				
SG26	O	200000	LIN-PIA-IMD-MEA-QTY-ALI-DTM-MOA-GIN-QVR-FTX-SG30-SG31-SG32-SG35-SG36-SG37-SG41-SG47			
60	QTY	O 1	Quantity To specify a pertinent quantity.			
Business Term	DE	EDIFACT	Format	St	*	Description
	C186	Quantity details		M		
	6063	Quantity type code qualifier	an..3	M	*	12 Despatch quantity
Despatched quantity	6060	Quantity	an..35	M		Note: Use only numeric values.
	6411	Measurement unit code	an..3	D		KGM kilogram LTR litre MTR metre All code values from EANCOM code list 6411 and UN/ECE Recommendation 20 code list available.
<p>Segmentstatus: Optional</p> <p>The QTY segment is used to specify the despatched quantity.</p> <p>DE 6411 is only used, if the article is a variable quantity article. Default value is piece.</p> <p>Example: QTY+12:10' The despatched quantity amounts to 10 pieces.</p>						

Max. Occ. = Maximum Occurrence, St = Status, * = Restricted Codes
 Status: M=Mandatory, R=Required, O=Optional, D=Dependent, A=Advised, N=Not used

Segment Layout

Detail section

No. Seg	St	Max. Occ.				
61	SG26	O 200000	LIN-PIA-IMD-MEA-QTY-ALI-DTM-MOA-GIN-QVR-FTX-SG30-SG31-SG32-SG35-SG36-SG37-SG41-SG47			
	QTY	O 1	Quantity To specify a pertinent quantity.			
Business Term	DE	EDIFACT	Format	St	*	Description
	C186	Quantity details		M		
	6063	Quantity type code qualifier	an..3	M	*	83 Backorder quantity
Backorder quantity	6060	Quantity	an..35	M		Note: Use only numeric values.
	6411	Measurement unit code	an..3	D		KGM kilogram LTR litre MTR metre All code values from EANCOM code list 6411 and UN/ECE Recommendation 20 code list available.
Segmentstatus: Optional						
The QTY segment is used to specify the backorder quantity.						
DE 6411 is only used, if the article is a variable quantity article. Default value is piece.						
Example: QTY+83:10' The backorder quantity amounts to 10 pieces.						

Max. Occ. = Maximum Occurrence, St = Status, * = Restricted Codes
Status: M=Mandatory, R=Required, O=Optional, D=Dependent, A=Advised, N=Not used

Segment Layout

Detail section

No. Seg	St	Max. Occ.				
62	SG26	O 200000	LIN-PIA-IMD-MEA-QTY-ALI-DTM-MOA-GIN-QVR-FTX-SG30-SG31-SG32-SG35-SG36-SG37-SG41-SG47			
	QTY	O 1	Quantity To specify a pertinent quantity.			
Business Term	DE	EDIFACT	Format	St	*	Description
	C186	Quantity details		M		
	6063	Quantity type code qualifier	an..3	M	*	192 Free goods quantity
Free Quantity	6060	Quantity	an..35	M		Note: Use only numeric values.
<p>Segmentstatus: Optional</p> <p>The QTY segment is used to specify the free quantity for the current order item, which was identified in the LIN segment. The free quantity is additional to the ordered quantity.</p> <p>DE 6411 is only used, if the article is a variable quantity article. Default value is piece.</p> <p>Example: QTY+192:20' The free quantity amounts to 20 pieces of the article no. described in the LIN segment. (GTIN).</p>						

Max. Occ. = Maximum Occurrence, St = Status, * = Restricted Codes
 Status: M=Mandatory, R=Required, O=Optional, D=Dependent, A=Advised, N=Not used

Segment Layout

Detail section

No. Seg	St	Max. Occ.				
SG26	O	200000	LIN-PIA-IMD-MEA-QTY-ALI-DTM-MOA-GIN-QVR-FTX-SG30-SG31-SG32-SG35-SG36-SG37-SG41-SG47			
63	DTM	D 1	Date/time/period To specify date, and/or time, or period.			
Business Term	DE	EDIFACT	Format	St	*	Description
	C507	Date/time/period		M		
	2005	Date or time or period function code qualifier	an..3	M	*	364 Minimum shelf life remaining at time of despatch period
Minimum remaining time / shelf-life	2380	Date or time or period value	an..35	R		
	2379	Date or time or period format code	an..3	R		102 CCYYMMDD 203 CCYYMMDDHHMM 718 CCYYMMDD- CCYYMMDD 804 Day Format of period to be given in actual message without hyphen.
Segmentstatus: Depending						
This segment is used by the supplier to specify an amendment of the minimum remaining time or shelf-life requested by the buyer.						
Example: DTM+364:200:804' Minimum remaining time / shelf-life of quantity is 200 days.						

Max. Occ. = Maximum Occurrence, St = Status, * = Restricted Codes
Status: M=Mandatory, R=Required, O=Optional, D=Dependent, A=Advised, N=Not used

Segment Layout

Detail section

No. Seg	St	Max. Occ.				
64	SG26	O 200000	LIN-PIA-IMD-MEA-QTY-ALI-DTM-MOA-GIN-QVR-FTX-SG30-SG31-SG32-SG35-SG36-SG37-SG41-SG47			
	DTM	D 1	Date/time/period To specify date, and/or time, or period.			
Business Term	DE	EDIFACT	Format	St	*	Description
	C507	Date/time/period		M		
	2005	Date or time or period function code qualifier	an..3	M	*	2 Delivery date/ time, requested
Delivery date, requested (detail section)	2380	Date or time or period value	an..35	R		
	2379	Date or time or period format code	an..3	R		102 CCYYMMDD 203 CCYYMMDDHHMM 718 CCYYMMDD- CCYYMMDD Format of period to be given in actual message without hyphen.
Segmentstatus: Depending						
This segment is used by the supplier to specify an amendment of the delivery date requested by the buyer. If this DTM segment is used at detail section, the specification from the heading section is overwritten.						
Example: DTM+2:20181028:102' This example requires the delivery on 28th of October 2018.						

Max. Occ. = Maximum Occurrence, St = Status, * = Restricted Codes
Status: M=Mandatory, R=Required, O=Optional, D=Dependent, A=Advised, N=Not used

Segment Layout

Detail section

No. Seg	St	Max. Occ.				
SG26	O	200000	LIN-PIA-IMD-MEA-QTY-ALI-DTM-MOA-GIN-QVR-FTX-SG30-SG31-SG32-SG35-SG36-SG37-SG41-SG47			
65	DTM	O 1	Date/time/period To specify date, and/or time, or period.			
Business Term	DE	EDIFACT	Format	St	*	Description
	C507	Date/time/period		M		
	2005	Date or time or period function code qualifier	an..3	M	*	64 Delivery date/time, earliest
Earliest delivery day (Detail section)	2380	Date or time or period value	an..35	R		
	2379	Date or time or period format code	an..3	R		102 CCYYMMDD 203 CCYYMMDDHHMM
<p>Segmentstatus: Optional</p> <p>The DTM segment is used to specify date and/or time or time period. If this DTM segment is used here at detail section, the specification from the heading section is overwritten.</p> <p>This segment is used, if required, for requested dates concerning the delivery of goods.</p> <p>Note DE 2005: The application of this code value excludes the use of the code values 2 and 69.</p> <p>Example: DTM+64:201810230800:203' This example requires the delivery at the earliest time on 23th of October 2018 at 8.00 a.m.</p>						

Max. Occ. = Maximum Occurrence, St = Status, * = Restricted Codes
 Status: M=Mandatory, R=Required, O=Optional, D=Dependent, A=Advised, N=Not used

Segment Layout

Detail section

No. Seg	St	Max. Occ.				
SG26	O	200000	LIN-PIA-IMD-MEA-QTY-ALI-DTM-MOA-GIN-QVR-FTX-SG30-SG31-SG32-SG35-SG36-SG37-SG41-SG47			
66	DTM	O 1	Date/time/period To specify date, and/or time, or period.			
Business Term	DE	EDIFACT	Format	St	*	Description
	C507	Date/time/period		M		
	2005	Date or time or period function code qualifier	an..3	M	*	63 Delivery date/ time, latest
Latest delivery date (Detail section)	2380	Date or time or period value	an..35	R		
	2379	Date or time or period format code	an..3	R		102 CCYYMMDD 203 CCYYMMDDHHMM
<p>Segmentstatus: Optional</p> <p>The DTM segment is used to specify date and/or time or time period. If this DTM segment is used here at detail section, the specification from the heading section is overwritten.</p> <p>This segment is used, if required, for requested dates concerning the delivery of goods.</p> <p>Note DE 2005: The application of this code value excludes the use of the code values 2 and 69</p> <p>Example: DTM+63:201810291500:203' This example requires the delivery at the latest time on 29th of October 2018 at 3.00 p.m.</p>						

Max. Occ. = Maximum Occurrence, St = Status, * = Restricted Codes
 Status: M=Mandatory, R=Required, O=Optional, D=Dependent, A=Advised, N=Not used

Segment Layout

Detail section

No. Seg	St	Max. Occ.				
SG26	O	200000	LIN-PIA-IMD-MEA-QTY-ALI-DTM-MOA-GIN-QVR-FTX-SG30-SG31-SG32-SG35-SG36-SG37-SG41-SG47			
67	DTM	D 1	Date/time/period To specify date, and/or time, or period.			
Business Term	DE	EDIFACT	Format	St	*	Description
	C507	Date/time/period		M		
	2005	Date or time or period function code qualifier	an..3	M	*	61 Cancel if not delivered by this date
Cancellation if not delivered (line item)	2380	Date or time or period value	an..35	R		
	2379	Date or time or period format code	an..3	R		102 CCYMMDD 203 CCYMMDDHHMM
<p>Segmentstatus: Cancellation of line item, if not delivered until the date requested.</p> <p>This segment is used to specify, where required, requested dates concerning the delivery of goods.</p> <p>Example: DTM+61:201810230800:203' The example request the cancellation if not delivered until 23th of October 2018 at 8.00 a.m.</p>						

Max. Occ. = Maximum Occurrence, St = Status, * = Restricted Codes
 Status: M=Mandatory, R=Required, O=Optional, D=Dependent, A=Advised, N=Not used

Segment Layout

Detail section

No. Seg	St	Max. Occ.				
SG26	O	200000	LIN-PIA-IMD-MEA-QTY-ALI-DTM-MOA-GIN-QVR-FTX-SG30-SG31-SG32-SG35-SG36-SG37-SG41-SG47			
68	DTM	O 1	Date/time/period To specify date, and/or time, or period.			
Business Term	DE	EDIFACT	Format	St	*	Description
	C507	Date/time/period		M		
	2005	Date or time or period function code qualifier	an..3	M	*	11 Despatch date and/or time
Despatch date, (detail section)	2380	Date or time or period value	an..35	R		
	2379	Date or time or period format code	an..3	R		102 CCYYMMDD 203 CCYYMMDDHHMM 718 CCYYMMDD-CCYYMMDD Format of period to be given in actual message without hyphen.
Segmentstatus: Optional						
<p>This segment is used by the supplier to specify an amendment of the delivery date requested by the buyer. If this DTM segment is used at detail section, the specification from the heading section is overwritten.</p> <p>Example: DTM+11:200181028:102' This example announces the delivery on 28th of October 2018.</p>						

Max. Occ. = Maximum Occurrence, St = Status, * = Restricted Codes
Status: M=Mandatory, R=Required, O=Optional, D=Dependent, A=Advised, N=Not used

Segment Layout

Detail section

No. Seg	St	Max. Occ.				
SG26	O	200000	LIN-PIA-IMD-MEA-QTY-ALI-DTM-MOA-GIN-QVR-FTX-SG30-SG31-SG32-SG35-SG36-SG37-SG41-SG47			
69	DTM	O 1	Date/time/period To specify date, and/or time, or period.			
Business Term	DE	EDIFACT	Format	St	*	Description
	C507	Date/time/period		M		
	2005	Date or time or period function code qualifier	an..3	M	*	44 Availability
Availability, (detail section)	2380	Date or time or period value	an..35	R		
	2379	Date or time or period format code	an..3	R		102 CCYYMMDD 203 CCYYMMDDHHMM 602 CCYY 610 CCYYMM 718 CCYYMMDD- CCYYMMDD Format of period to be given in actual message without hyphen.
Segmentstatus: Optional						
This segment is used by the supplier to specify an availability date for the article.						
Example: DTM+44:20181028:102' The article is available on 28th of October 2018.						

Max. Occ. = Maximum Occurrence, St = Status, * = Restricted Codes
 Status: M=Mandatory, R=Required, O=Optional, D=Dependent, A=Advised, N=Not used

Segment Layout

Detail section

No. Seg	St	Max. Occ.				
70			SG26	O	200000	LIN-PIA-IMD-MEA-QTY-ALI-DTM-MOA-GIN-QVR-FTX-SG30-SG31-SG32-SG35-SG36-SG37-SG41-SG47
			DTM	O	1	Date/time/period To specify date, and/or time, or period.
Business Term	DE	EDIFACT	Format	St	*	Description
	C507	Date/time/period		M		
	2005	Date or time or period function code qualifier	an..3	M	*	67 Delivery date/ time, current schedule
Schedule (Detail section)	2380	Date or time or period value	an..35	R		
	2379	Date or time or period format code	an..3	R		102 CCYYMMDD 203 CCYYMMDDHHMM 602 CCYY 610 CCYYMM 718 CCYYMMDD- CCYYMMDD Format of period to be given in actual message without hyphen.
Segmentstatus: Optional						
This segment is used when the item is delivered according to the agreed schedule.						
Example: DTM+67:20181028:102'						
The schedule (Detail section) is available on 28th of October 2018.						

Max. Occ. = Maximum Occurrence, St = Status, * = Restricted Codes
 Status: M=Mandatory, R=Required, O=Optional, D=Dependent, A=Advised, N=Not used

Segment Layout

Detail section

No. Seg	St	Max. Occ.				
71	SG26	O 200000	LIN-PIA-IMD-MEA-QTY-ALI-DTM-MOA-GIN-QVR-FTX-SG30-SG31-SG32-SG35-SG36-SG37-SG41-SG47			
	QVR	D 1	Quantity variances To specify item details relating to quantity variances.			
Business Term	DE	EDIFACT	Format	St	*	Description
	C279	Quantity difference information		R		
Quantity difference	6064	Quantity variance value	n..15	M		
	6063	Quantity type code qualifier	an..3	R	*	21 Ordered quantity
	4221	Discrepancy nature identification code	an..3	O		AC Over-shipped AC = Code indicating that there was an excess quantity of goods in a shipment relative to the order. BP Shipment partial - back order to follow BP = The shipment is incomplete, the missing quantities are to follow. CP Shipment partial - considered complete, no backorder CP = Shipment does not fulfil the complete order but should be considered complete. Unshipped items are not considered to be on backorder. IC Item cancelled IC = The code indicates that the item was canceled by the supplier.
	C960	Reason for change		R		
	4295	Change reason description code	an..3	R		AQ Alternate quantity and unit of measurement ARP Article to be published (GS1 Temporary Code) AV Out of inventory BJ Item identification code unknown BL Item represents substitution from original order WR Temporarily unavailable
Segmentstatus: Depending						

Max. Occ. = Maximum Occurrence, St = Status, * = Restricted Codes
 Status: M=Mandatory, R=Required, O=Optional, D=Dependent, A=Advised, N=Not used

Segment Layout

Detail section

This segment is used by the supplier to specify an amendment of the quantity requested by the buyer.

This segment is used to specify any variances between what was ordered and what is planned for being despatched.

The quantity identified in DE 6064 must always refer to the difference between the quantity planned for delivery identified in DE 6060 of QTY at LIN level and the ordered quantity (QTY+12 minus QTY+21, not converse). For negative values (e.g. partial shipment) the variance must be expressed as negative.

Example: QVR+-4:21+BP+BJ'

The quantity difference is 4 units.

Segment Layout

Detail section

No. Seg	St	Max. Occ.				
72	SG26	O 200000	LIN-PIA-IMD-MEA-QTY-ALI-DTM-MOA-GIN-QVR-FTX-SG30-SG31-SG32-SG35-SG36-SG37-SG41-SG47			
	FTX	O 1	Free text To provide free form or coded text information.			
Business Term	DE	EDIFACT	Format	St	*	Description
	4451	Text subject code qualifier	an..3	M	*	PUR Purchasing information
	4453	Free text function code	an..3	O	*	1 Text for subsequent use
	C107	Text reference		D		
Order qualifier	4441	Free text value code	an..17	M	*	DUN Do not record dues (supply only if immediately available) DUY Record dues (backorder if not immediately available) PKN Backorder until agreed order volume is reached, no PKY Backorder until agreed order volume is reached, yes TUN Do not supply replacement article TUY Automatic supply of replacement article FSN Order not forwarded to publisher FSY Order forwarded to publisher
	1131	Code list identification code	an..17	R	*	MEDIA Media (fix value)
	3055	Code list responsible agency code	an..3	R	*	246 GS1 Germany
Segmentstatus: Optional						
This segment is used to advice order qualifiers for the line item.						
This indication overwrites the information given in the heading-section.						

Max. Occ. = Maximum Occurrence, St = Status, * = Restricted Codes
 Status: M=Mandatory, R=Required, O=Optional, D=Dependent, A=Advised, N=Not used

Segment Layout

Detail section

Example: FTX+PUR+1+DUN:MEDIA:246 '
Do not record dues.

Max. Occ. = Maximum Occurrence, St = Status, * = Restricted Codes
Status: M=Mandatory, R=Required, O=Optional, D=Dependent, A=Advised, N=Not used

Segment Layout

Detail section

No. Seg	St	Max. Occ.				
73			SG26	O	200000	LIN-PIA-IMD-MEA-QTY-ALI-DTM-MOA-GIN-QVR-FTX-SG30-SG31-SG32-SG35-SG36-SG37-SG41-SG47
			FTX	O	1	Free text To provide free form or coded text information.
Business Term	DE	EDIFACT	Format	St	*	Description
	4451	Text subject code qualifier	an..3	M	*	DEL Delivery information
	4453	Free text function code	an..3	O	*	1 Text for subsequent use
	C107	Text reference		D		
Reason qualifier	4441	Free text value code	an..17	M		Use list "Einheitliche Meldenummern aus der Liste des Börsenvereins des deutschen Buchhandels e.V." (https://www.boersenverein.de/fileadmin/bundesverband/dokumente/interessengruppen/ig_pro/Einheitliche_Meldenummern_im_Buchhandel_Stand_April_2020.pdf) 15 Currently out of stock
	1131	Code list identification code	an..17	R	*	BOEV BOEV (fix value)
	3055	Code list responsible agency code	an..3	R	*	246 GS1 Germany
Segmentstatus: Optional						
This segment is used to advice reason qualifiers (Meldenummern des Börsenvereins des deutschen Buchhandels) for the substituted/changed line item.						
Example: FTX+DEL+1+15:BOEV:246' Reason for change						

Max. Occ. = Maximum Occurrence, St = Status, * = Restricted Codes
Status: M=Mandatory, R=Required, O=Optional, D=Dependent, A=Advised, N=Not used

Segment Layout

Detail section

No. Seg	St	Max. Occ.				
SG26	O	200000	LIN-PIA-IMD-MEA-QTY-ALI-DTM-MOA-GIN-QVR-FTX-SG30-SG31-SG32-SG35-SG36-SG37-SG41-SG47			
SG30	D	1	PRI-CUX-DTM			
PRI	M	1	Price details			
74	To specify price information.					
Business Term	DE	EDIFACT	Format	St	*	Description
	C509	Price information		R		
	5125	Price code qualifier	an..3	M		AAA Calculation net
List price per ordered unit	5118	Price amount	n..15	R		
	5375	Price type code	an..3	N		
	5387	Price specification code	an..3	O	*	LIU List price (GS1 Temporary Code)
Segmentstatus: Depending						
This segment is used by the supplier to specify an amendment of the price requested by the buyer.						
In the EANCOM order only the net calculation method may be used. Possible condition specification in the ALC group is only for information.						
Example: PRI+AAA:10::LIU'						
Net list purchase price: 10 EURO						

Max. Occ. = Maximum Occurrence, St = Status, * = Restricted Codes
 Status: M=Mandatory, R=Required, O=Optional, D=Dependent, A=Advised, N=Not used

Segment Layout

Detail section

No. Seg	St	Max. Occ.				
SG26	O	200000	LIN-PIA-IMD-MEA-QTY-ALI-DTM-MOA-GIN-QVR-FTX-SG30-SG31-SG32-SG35-SG36-SG37-SG41-SG47			
SG30	D	1	PRI-CUX-DTM			
PRI	M	1	Price details			
75	To specify price information.					
Business Term	DE	EDIFACT	Format	St	*	Description
	C509	Price information		R		
	5125	Price code qualifier	an..3	M	*	AAA Calculation net
Net retail price	5118	Price amount	n..15	R		
<p>Segmentstatus: Depending</p> <p>This segment is used to specify the type of price (net sale price, gross sale price or fixed retail price) valid for the article.</p> <p>Example: PRI+AAA:17.58' The net sale price per piece is 17.58 EURO excl. tax.</p>						

Max. Occ. = Maximum Occurrence, St = Status, * = Restricted Codes
 Status: M=Mandatory, R=Required, O=Optional, D=Dependent, A=Advised, N=Not used

Segment Layout

Detail section

No. Seg	St	Max. Occ.				
SG26	O	200000	LIN-PIA-IMD-MEA-QTY-ALI-DTM-MOA-GIN-QVR-FTX-SG30-SG31-SG32-SG35-SG36-SG37-SG41-SG47			
SG30	D	1	PRI-CUX-DTM			
CUX	O	1	Currencies			
76						To specify currencies used in the transaction and relevant details for the rate of exchange.
Business Term	DE	EDIFACT	Format	St	*	Description
	C504	Currency details		R		
	6347	Currency usage code qualifier	an..3	M	*	2 Reference currency
Currency code price	6345	Currency identification code	an..3	R		ISO 4217 3-Alpha Code
	6343	Currency type code qualifier	an..3	R	*	10 Pricing currency
Segmentstatus: Optional						
This segment is used to indicate currency specification for the price.						
Example: CUX+2:EUR:10'						
Price Currency is EURO						

Max. Occ. = Maximum Occurrence, St = Status, * = Restricted Codes
 Status: M=Mandatory, R=Required, O=Optional, D=Dependent, A=Advised, N=Not used

Segment Layout

Detail section

No. Seg	St	Max. Occ.				
SG26	O	200000	LIN-PIA-IMD-MEA-QTY-ALI-DTM-MOA-GIN-QVR-FTX-SG30-SG31-SG32-SG35-SG36-SG37-SG41-SG47			
SG30	D	1	PRI-CUX-DTM			
PRI	M	1	Price details			
77			To specify price information.			
Business Term	DE	EDIFACT	Format	St	*	Description
	C509	Price information		R		
	5125	Price code qualifier	an..3	M	*	AAE Information price, excluding allowances or charges, including taxes
Suggested retail price	5118	Price amount	n..15	R		
	5375	Price type code	an..3	O	*	CA Catalogue
	5387	Price specification code	an..3	R	*	SRP Suggested retail price
<p>Segmentstatus: Depending</p> <p>This segment is used to specify the type of price (net sale price, gross sale price or fixed retail price) valid for the article.</p> <p>If it is a supplier generated order (BGM DE 1001 = 22E), the supplier can indicate his suggested selling price with the code value "SRP".</p> <p>Example: PRI+AAE:19.98:CA:SRP'</p> <p>The recommended gross retail price per piece is 19.98 EURO incl. tax.</p>						

Max. Occ. = Maximum Occurrence, St = Status, * = Restricted Codes
 Status: M=Mandatory, R=Required, O=Optional, D=Dependent, A=Advised, N=Not used

Segment Layout

Detail section

No. Seg	St	Max. Occ.				
SG26	O	200000	LIN-PIA-IMD-MEA-QTY-ALI-DTM-MOA-GIN-QVR-FTX-SG30-SG31-SG32-SG35-SG36-SG37-SG41-SG47			
SG30	D	1	PRI-CUX-DTM			
CUX	O	1	Currencies			
78						To specify currencies used in the transaction and relevant details for the rate of exchange.
Business Term	DE	EDIFACT	Format	St	*	Description
	C504	Currency details		R		
	6347	Currency usage code qualifier	an..3	M	*	2 Reference currency
Currency code price	6345	Currency identification code	an..3	R		ISO 4217 3-Alpha Code
	6343	Currency type code qualifier	an..3	R	*	10 Pricing currency
Segmentstatus: Optional						
This segment is used to indicate currency specification for the price.						
Example: CUX+2:EUR:10'						
Price Currency is EURO						

Max. Occ. = Maximum Occurrence, St = Status, * = Restricted Codes
 Status: M=Mandatory, R=Required, O=Optional, D=Dependent, A=Advised, N=Not used

Segment Layout

Detail section

No. Seg	St	Max. Occ.				
SG26	O	200000	LIN-PIA-IMD-MEA-QTY-ALI-DTM-MOA-GIN-QVR-FTX-SG30-SG31-SG32-SG35-SG36-SG37-SG41-SG47			
SG30	D	1	PRI-CUX-DTM			
PRI	M	1	Price details			
79	To specify price information.					
Business Term	DE	EDIFACT	Format	St	*	Description
	C509	Price information		R		
	5125	Price code qualifier	an..3	M	*	AAE Information price, excluding allowances or charges, including taxes
Fixed Retail price	5118	Price amount	n..15	R		
	5375	Price type code	an..3	O	*	CA Catalogue
	5387	Price specification code	an..3	R	*	RTP Retail price
<p>Segmentstatus: Depending, status of segment is mandatory, if a fixed retail price must be used for this article.</p> <p>This segment is used to specify the type of price (net sale price, gross sale price or fixed retail price) valid for the article.</p> <p>Example: PRI+AAE:19.98:CA:RTP'</p> <p>The fixed retail price per piece is 19.98 EURO incl. tax.</p>						

Max. Occ. = Maximum Occurrence, St = Status, * = Restricted Codes
 Status: M=Mandatory, R=Required, O=Optional, D=Dependent, A=Advised, N=Not used

Segment Layout

Detail section

No. Seg	St	Max. Occ.				
SG26	O	200000	LIN-PIA-IMD-MEA-QTY-ALI-DTM-MOA-GIN-QVR-FTX-SG30-SG31-SG32-SG35-SG36-SG37-SG41-SG47			
SG30	D	1	PRI-CUX-DTM			
CUX	O	1	Currencies			
80						To specify currencies used in the transaction and relevant details for the rate of exchange.
Business Term	DE	EDIFACT	Format	St	*	Description
	C504	Currency details		R		
	6347	Currency usage code qualifier	an..3	M	*	2 Reference currency
Currency code price	6345	Currency identification code	an..3	R		ISO 4217 3-Alpha Code
	6343	Currency type code qualifier	an..3	R	*	10 Pricing currency
Segmentstatus: Optional						
This segment is used to indicate currency specification for the fixed retail price.						
Example: CUX+2:EUR:10'						
Price Currency is EURO						

Max. Occ. = Maximum Occurrence, St = Status, * = Restricted Codes
 Status: M=Mandatory, R=Required, O=Optional, D=Dependent, A=Advised, N=Not used

Segment Layout

Detail section

No. Seg	St	Max. Occ.				
SG26	O	200000	LIN-PIA-IMD-MEA-QTY-ALI-DTM-MOA-GIN-QVR-FTX-SG30-SG31-SG32-SG35-SG36-SG37-SG41-SG47			
SG31	O	1	RFF-DTM			
RFF	M	1	Reference			
To specify a reference.						
Business Term	DE	EDIFACT	Format	St	*	Description
	C506	Reference		M		
	1153	Reference code qualifier	an..3	M	*	CR Customer reference number
Order reference	1154	Reference identifier	an..70	R		
Segmentstatus: Optional						
This RFF segment is used to indicate a order reference relevant for the order response line.						
This indication overwrites the information given in the heading-section.						
Example: RFF+CR:4711'						
The order reference for the position of the order response is 4711.						

Max. Occ. = Maximum Occurrence, St = Status, * = Restricted Codes
 Status: M=Mandatory, R=Required, O=Optional, D=Dependent, A=Advised, N=Not used

Segment Layout

Detail section

No. Seg	St	Max. Occ.				
SG26	O	200000	LIN-PIA-IMD-MEA-QTY-ALI-DTM-MOA-GIN-QVR-FTX-SG30-SG31-SG32-SG35-SG36-SG37-SG41-SG47			
SG31	D	1	RFF-DTM			
RFF	M	1	Reference			
82	To specify a reference.					
Business Term	DE	EDIFACT	Format	St	*	Description
	C506	Reference		M		
	1153	Reference code qualifier	an..3	M	*	SS Seller's reference number
Sellers reference number	1154	Reference identifier	an..70	R		
<p>Segmentstatus: Depending</p> <p>This RFF segment is used to indicate a sellers reference number relevant for the order response line.</p> <p>This indication overwrites the information given in the heading-section.</p> <p>Example: RFF+SS:4711' The order response line is based on sellers reference no. 4711.</p>						

Max. Occ. = Maximum Occurrence, St = Status, * = Restricted Codes
 Status: M=Mandatory, R=Required, O=Optional, D=Dependent, A=Advised, N=Not used

Segment Layout

Detail section

No. Seg	St	Max. Occ.				
SG26	O	200000	LIN-PIA-IMD-MEA-QTY-ALI-DTM-MOA-GIN-QVR-FTX-SG30-SG31-SG32-SG35-SG36-SG37-SG41-SG47			
SG31	O	1	RFF-DTM			
RFF	M	1	Reference			
83	To specify a reference.					
Business Term	DE	EDIFACT	Format	St	*	Description
	C506	Reference		M		
	1153	Reference code qualifier	an..3	M	*	SD Sales department number
Number of salesdepartment	1154	Reference identifier	an..70	R		
Segmentstatus: Optional						
This RFF segment is used to indicate a department reference relevant for the order response line.						
Example: RFF+SD:4711'						
The order response line is for department 4711.						

Max. Occ. = Maximum Occurrence, St = Status, * = Restricted Codes
 Status: M=Mandatory, R=Required, O=Optional, D=Dependent, A=Advised, N=Not used

Segment Layout

Detail section

No. Seg	St	Max. Occ.				
SG26	O	200000	LIN-PIA-IMD-MEA-QTY-ALI-DTM-MOA-GIN-QVR-FTX-SG30-SG31-SG32-SG35-SG36-SG37-SG41-SG47			
SG31	O	1	RFF-DTM			
RFF	M	1	Reference			
84	To specify a reference.					
Business Term	DE	EDIFACT	Format	St	*	Description
	C506	Reference		M		
	1153	Reference code qualifier	an..3	M	*	PD Promotion deal number
Promotion deal number (line level)	1154	Reference identifier	an..70	R		
Segmentstatus: Optional						
This RFF segment is used to indicate a promotion deal number relevant for the order response line.						
This indication overwrites the information given in the heading-section.						
Example: RFF+PD:4711'						
The order response line is based on promotion deal no. 4711.						

Max. Occ. = Maximum Occurrence, St = Status, * = Restricted Codes
 Status: M=Mandatory, R=Required, O=Optional, D=Dependent, A=Advised, N=Not used

Segment Layout

Detail section

No. Seg	St	Max. Occ.				
SG26	O	200000	LIN-PIA-IMD-MEA-QTY-ALI-DTM-MOA-GIN-QVR-FTX-SG30-SG31-SG32-SG35-SG36-SG37-SG41-SG47			
SG31	O	1	RFF-DTM			
RFF	M	1	Reference			
85	To specify a reference.					
Business Term	DE	EDIFACT	Format	St	*	Description
	C506	Reference		M		
	1153	Reference code qualifier	an..3	M	*	LI Line item reference number
Line item reference (line level)	1154	Reference identifier	an..70	R		
Line number from order indicator (Line item reference).	1156	Document line identifier	an..6	D		This data element is only used to reference line numbers from previous order indicator (Line item reference).
Segmentstatus: Optional						
This RFF segment is used to indicate a line item reference relevant for the order line.						
Example: RFF+LI:4711:X'						
The order line is based on line item reference 4711.						

Max. Occ. = Maximum Occurrence, St = Status, * = Restricted Codes
 Status: M=Mandatory, R=Required, O=Optional, D=Dependent, A=Advised, N=Not used

Segment Layout

Detail section

No. Seg	St	Max. Occ.				
SG26	O	200000	LIN-PIA-IMD-MEA-QTY-ALI-DTM-MOA-GIN-QVR-FTX-SG30-SG31-SG32-SG35-SG36-SG37-SG41-SG47			
SG31	D	1	RFF-DTM			
RFF	M	1	Reference			
86	To specify a reference.					
Business Term	DE	EDIFACT	Format	St	*	Description
	C506	Reference		M		
	1153	Reference code qualifier	an..3	M	*	AXO Product certification number (Old code value: XC1)
ECO controlling agency (article)	1154	Reference identifier	an..70	R		
Segmentstatus: Depending						
This segment services the requirements of EC 834/2007.						
Example: RFF+AXO:AT-N-01-BIO'						
The article is a BIO product. It is certified by the control agency AT-N-01-BIO. The indication overwrites information of the heading section.						

Max. Occ. = Maximum Occurrence, St = Status, * = Restricted Codes
 Status: M=Mandatory, R=Required, O=Optional, D=Dependent, A=Advised, N=Not used

Segment Layout

Detail section

No. Seg	St	Max. Occ.				
SG26	O	200000	LIN-PIA-IMD-MEA-QTY-ALI-DTM-MOA-GIN-QVR-FTX-SG30-SG31-SG32-SG35-SG36-SG37-SG41-SG47			
SG32	D	99	PAC-QTY-SG34			
PAC	M	1	Package			
87	To describe the number and type of packages/physical units.					
Business Term	DE	EDIFACT	Format	St	*	Description
Number of packages	7224	Package quantity	n..8	O		
	C531	Packaging details		O		
	7075	Packaging level code	an..3	N		
	7233	Packaging related description code	an..3	O		50 Package barcoded EAN-13 or EAN-8 51 Package barcoded ITF-14 52 Package barcoded UCC or EAN-128
	7073	Packaging terms and conditions code	an..3	N		
	C202	Package type		O		
Type of package	7065	Package type description code	an..17	A		Textile meaning: lying Textile meaning: hanging
	1131	Code list identification code	an..17	O		
	3055	Code list responsible agency code	an..3	D		9 GS1
	7064	Type of packages	an..35	N		
	C402	Package type identification		N		
	7077	Description format code	an..3			
	C532	Returnable package details		D		
	8395	Returnable package freight payment responsibility code	an..3	O		1 Paid by customer 3 Paid by supplier
Segmentstatus: Depending						
This segment is used by the supplier to specify an amendment of the packaging details requested by the buyer.						
Example: PAC+9+:50+BX::9++1'						
The order line contains of 9 boxes marked with EAN-13.						

Max. Occ. = Maximum Occurrence, St = Status, * = Restricted Codes
 Status: M=Mandatory, R=Required, O=Optional, D=Dependent, A=Advised, N=Not used

Segment Layout

Detail section

No. Seg	St	Max. Occ.				
SG26	O	200000	LIN-PIA-IMD-MEA-QTY-ALI-DTM-MOA-GIN-QVR-FTX-SG30-SG31-SG32-SG35-SG36-SG37-SG41-SG47			
SG36	D	1	TAX-MOA			
TAX	M	1	Duty/tax/fee details			
88			To specify relevant duty/tax/fee information.			
Business Term	DE	EDIFACT	Format	St	*	Description
	5283	Duty or tax or fee function code qualifier	an..3	M	*	7 Tax
	C241	Duty/tax/fee type		D		
Value added tax on line level	5153	Duty or tax or fee type name code	an..3	O	*	VAT Value added tax
	1131	Code list identification code	an..17	O		
	3055	Code list responsible agency code	an..3	D		
	5152	Duty or tax or fee type name	an..35	O		
	C533	Duty/tax/fee account detail		O		
	5289	Duty or tax or fee account code	an..6	M		
	1131	Code list identification code	an..17	O		
	3055	Code list responsible agency code	an..3	D		
	5286	Duty or tax or fee assessment basis value	an..15	O		
	C243	Duty/tax/fee detail		A		
	5279	Duty or tax or fee rate code	an..7	O		
	1131	Code list identification code	an..17	O		
	3055	Code list responsible agency code	an..3	D		
	5278	Duty or tax or fee rate	an..17	R		Actual tax rate
	5273	Duty or tax or fee rate basis code	an..12	O		
	1131	Code list identification code	an..17	O		
	3055	Code list responsible agency code	an..3	D		
	5305	Duty or tax or fee category code	an..3	R		E Exempt from tax S Standard rate O Services outside scope of tax
Segmentstatus: Depending, is only used if the current line has a VAT rate other than indicated in SG7.						

Max. Occ. = Maximum Occurrence, St = Status, * = Restricted Codes

Status: M=Mandatory, R=Required, O=Optional, D=Dependent, A=Advised, N=Not used

Segment Layout

Detail section

The main tax rate has been indicated in the heading section of the message. Should the occasion arise different tax rates have to be indicated here on detail level.

Note to DE 5278 and 5305: if the business volume is free of tax, DE 5278 must contain 0 (zero).

Example: TAX+7+VAT+123ABC++:::19+S'

The VAT rate for the current line item is 19%.

Segment Layout

Detail section

No. Seg	St	Max. Occ.				
SG26	O	200000	LIN-PIA-IMD-MEA-QTY-ALI-DTM-MOA-GIN-QVR-FTX-SG30-SG31-SG32-SG35-SG36-SG37-SG41-SG47			
SG37	O	1	NAD-SG40			
NAD	M	1	Name and address			
89	To specify the name/address and their related function, either by C082 only and/or unstructured by C058 or structured by C080 thru 3207.					
Business Term	DE	EDIFACT	Format	St	*	Description
	3035	Party function code qualifier	an..3	M	*	GZ Substitute supplier
	C082	Party identification details		D		
GLN of the substitute supplier	3039	Party identifier	an..35	M		Global Location Number (GLN) - Format n13
	1131	Code list identification code	an..17	N		
	3055	Code list responsible agency code	an..3	R	*	9 GS1
Segmentstatus: Optional						
This NAD segment identifies the substitute supplier if the main usual supplier be unable to do so.						
The substitute supplier is identified by GLN.						
Example: NAD+GZ+4089876986411::9'						
The substitute supplier is identified by GLN 4089876986411.						

Max. Occ. = Maximum Occurrence, St = Status, * = Restricted Codes
 Status: M=Mandatory, R=Required, O=Optional, D=Dependent, A=Advised, N=Not used

Segment Layout

Detail section

No. Seg	St	Max. Occ.				
SG26	O	200000	LIN-PIA-IMD-MEA-QTY-ALI-DTM-MOA-GIN-QVR-FTX-SG30-SG31-SG32-SG35-SG36-SG37-SG41-SG47			
SG41	O	99	ALC-ALI-DTM-SG42-SG43-SG44-SG45-SG46			
90 ALC	M	1	Allowance or charge			
To identify allowance or charge details.						
Business Term	DE	EDIFACT	Format	St	*	Description
Article condition	5463	Allowance or charge code qualifier	an..3	M	*	A Allowance C Charge
	C552	Allowance/charge information		O		
	1230	Allowance or charge identifier	an..35	N		
	5189	Allowance or charge identification code	an..3	N		
	4471	Settlement means code	an..3	N		
	1227	Calculation sequence code	an..3	N		
	C214	Special services identification		O		
	7161	Special service description code	an..3	R		DI Discount Discount (document)
Segmentstatus: Optional						
This segment is used to specify any allowances or charges which are applicable for the current line item. Separate repetitions of the segmentgroup 43 must be used, if there are further allowances or charges for the same position.						
Example: ALC+A++++DI ' Condition for information: Allowance						

Max. Occ. = Maximum Occurrence, St = Status, * = Restricted Codes
 Status: M=Mandatory, R=Required, O=Optional, D=Dependent, A=Advised, N=Not used

Segment Layout

Detail section

No. Seg	St	Max. Occ.				
SG26	O	200000	LIN-PIA-IMD-MEA-QTY-ALI-DTM-MOA-GIN-QVR-FTX-SG30-SG31-SG32-SG35-SG36-SG37-SG41-SG47			
SG41	O	99	ALC-ALI-DTM-SG42-SG43-SG44-SG45-SG46			
SG43	D	1	PCD-RNG			
91 PCD	M	1	Percentage details To specify percentage information.			
Business Term	DE	EDIFACT	Format	St	*	Description
	C501	Percentage details		M		
	5245	Percentage type code qualifier	an..3	M	*	3 Allowance or charge
Percentage of allowance/charge	5482	Percentage	n..10	R		
Segmentstatus: Depending						
This segment is used by the supplier to specify the conditions (percentage).						
Example: PCD+3:5' 5 percent						

Max. Occ. = Maximum Occurrence, St = Status, * = Restricted Codes
 Status: M=Mandatory, R=Required, O=Optional, D=Dependent, A=Advised, N=Not used

Segment Layout

Detail section

No. Seg	St	Max. Occ.				
SG26	O	200000	LIN-PIA-IMD-MEA-QTY-ALI-DTM-MOA-GIN-QVR-FTX-SG30-SG31-SG32-SG35-SG36-SG37-SG41-SG47			
SG41	O	99	ALC-ALI-DTM-SG42-SG43-SG44-SG45-SG46			
SG44	O	2	MOA-RNG			
92 MOA	M	1	Monetary amount To specify a monetary amount.			
Business Term	DE	EDIFACT	Format	St	*	Description
	C516	Monetary amount		M		
	5025	Monetary amount type code qualifier	an..3	M	*	25 Charge/allowance basis
Basis amount allowance/charge (line level)	5004	Monetary amount	n..35	R		
Segmentstatus: Optional						
This segment is used to provide the basis amount to calculate an allowance or charge.						
Example: MOA+25:220'						
Basis amount: 220 EURO						

Max. Occ. = Maximum Occurrence, St = Status, * = Restricted Codes
 Status: M=Mandatory, R=Required, O=Optional, D=Dependent, A=Advised, N=Not used

Segment Layout

Summary section

Summary section

No. Seg	St	Max. Occ.				
93	UNS	M 1	Section control			
To separate header, detail and summary sections of a message.						
Notes:						
1. To be used by message designers when required to avoid ambiguities. Mandatory only if specified for the type of message concerned.						
Business Term	DE	EDIFACT	Format	St	*	Description
	0081	Section identification	a1	M	*	S Detail/summary section separation
Segmentstatus: Mandatory						
This segment is used to separate the detail and summary section of the message.						
The UNS segment has only a syntactic function						
Example: UNS+S'						
Separation between detail and summary section						

Max. Occ. = Maximum Occurrence, St = Status, * = Restricted Codes
 Status: M=Mandatory, R=Required, O=Optional, D=Dependent, A=Advised, N=Not used

Segment Layout

Summary section

No.	Seg	St	Max. Occ.			
94	MOA	O	1	Monetary amount To specify a monetary amount.		
Business Term	DE	EDIFACT	Format	St	*	Description
	C516	Monetary amount		M		
	5025	Monetary amount type code qualifier	an..3	M	*	79 Total line items amount
Total line items amount	5004	Monetary amount	n..35	R		
Segmentstatus: Optional						
This segment can be used by the supplier to specify an amendment of the monetary value of the buyers order.						
Example: MOA+79:200' The total line itme amount is 200 EUR.						

Max. Occ. = Maximum Occurrence, St = Status, * = Restricted Codes
Status: M=Mandatory, R=Required, O=Optional, D=Dependent, A=Advised, N=Not used

Segment Layout

Summary section

No. Seg	St	Max. Occ.				
95	UNT	M 1	Message trailer To end and check the completeness of a message.			
Business Term	DE	EDIFACT	Format	St	*	Description
Total number of segments in the message	0074	Number of segments in the message	n..6	M		
	0062	Message reference number	an..14	M		The reference number from the UNH segment must be repeated here Unambiguous message reference number (identical with DE 0062 in the UNH segment)
Segmentstatus: Mandatory						
This segment is a mandatory UN/EDIFACT segment. It must always be the last segment in the message.						
Example: UNT+101+1' Number of segments in the message.						

Max. Occ. = Maximum Occurrence, St = Status, * = Restricted Codes
 Status: M=Mandatory, R=Required, O=Optional, D=Dependent, A=Advised, N=Not used

Segment Layout

No. Seg	St	Max. Occ.				
96	UNZ	M 1	Interchange trailer To end and check the completeness of an interchange.			
Business Term	DE	EDIFACT	Format	St	*	Description
End of the transmission file, Number of messages or message groups	0036	Interchange control count	n..6	M		Number of messages or message groups in the transmission file.
Interchange control reference, end	0020	Interchange control reference	an..14	M		Interchange control reference, identical with UNB DE 0020.
<p>Segmentstatus: Mandatory</p> <p>The UNZ segment is the last segment of the transmission file.</p> <p>Note DE 0036: If functional groups are not used, this is the number of messages within the interchange.</p> <p>Example: UNZ+1+4711' The transmission file contains 1 message.</p>						

Max. Occ. = Maximum Occurrence, St = Status, * = Restricted Codes
 Status: M=Mandatory, R=Required, O=Optional, D=Dependent, A=Advised, N=Not used

Used Codes

0001	<p>Syntax identifier Coded identification of the agency controlling a syntax and syntax level used in an interchange.</p> <p>Notes: 1. a3, upper case, Controlling Agency (e.g. UNO=UN/ECE) and a1 stating level (e.g. A) (which together give UNOA).</p>
UNOA	<p>UN/ECE level A As defined in the basic code table of ISO 646 with the exceptions of lower case letters, alternative graphic character allocations and national or application-oriented graphic character allocations.</p>
UNOB	<p>UN/ECE level B As defined in the basic code table of ISO 646 with the exceptions of alternative graphic character allocations and national or application-oriented graphic character allocations.</p>
UNOC	<p>UN/ECE level C As defined in ISO/IEC 8859-1 : Information technology - Part 1: Latin alphabet No. 1.</p>
UNOD	<p>UN/ECE level D As defined in ISO/IEC 8859-2 : Information technology - Part 2: Latin alphabet No. 2.</p>
UNOE	<p>UN/ECE level E As defined in ISO/IEC 8859-5 : Information technology - Part 5: Latin/Cyrillic alphabet.</p>
UNOF	<p>UN/ECE level F As defined in ISO 8859-7 : Information processing - Part 7: Latin/Greek alphabet.</p>
0002	<p>Syntax version number Version number of the syntax identified in the syntax identifier (0001)</p> <p>Notes: 1. Increments 1 for each version.</p>
3	<p>Version 3 ISO 9735 Amendment 1:1992. GS1 Description: Syntax version number 3. This code can be used with all of the character sets (A, B, C, D, E and F).</p>

Used Codes

0007	Partner identification code qualifier Qualifier referring to the source of codes for the identifiers of interchanging partners.
	Notes: 1. Used with sender/recipient identification code.
14	GS1 Partner identification code assigned by GS1, an international organization of GS1 Member Organizations that manages the GS1 System.
0025	Recipient's reference/password qualifier Qualifier for the recipient's reference or password.
	Notes: 1. If specified in IA.
AA	Reference Recipient's reference/password is a reference.
BB	Password Recipient's reference/password is a password.
0029	Processing priority code Code determined by the sender requesting processing priority for the interchange.
	Notes: 1. Used if specified in IA.
A	Highest priority Requested processing priority is the highest.
0031	Acknowledgement request Code determined by the sender for acknowledgement of the interchange.
	Notes: 1. Set = 1 if sender requests acknowledgement, i.e. UNB and UNZ segments received and identified.
1	Requested Acknowledgement is requested.
0035	Test indicator Indication that the interchange is a test.
	Notes: 1. Set = 1 if the interchange is a test. Otherwise not used.

Used Codes

1	Interchange is a test Indicates that the interchange is a test.
0051	Controlling agency Code to identify the agency controlling the specification, maintenance and publication of the message type.
UN	UN/CEFACT United Nations Centre for Trade Facilitation and Electronic Business (UN/CEFACT). GS1 Description: UN Economic Commission for Europe (UN/ECE), Committee on the development of trade (TRADE), Working Party on facilitation of international trade procedures (WP.4).
0052	Message version number Version number of a message type. Notes: 1. If UNG/UNE is used, shall be identical in UNG and UNE. The representation of 0052 was specified as n..3 in version 1 of ISO 9735.
D	Draft version/UN/EDIFACT Directory Message approved and issued as a draft message (Valid for directories published after March 1993 and prior to March 1997). Message approved as a standard message (Valid for directories published after March 1997).
0054	Message release number Release number within the current message type version number (0052). Notes: 1. The representation of 0054 was specified as n..3 in version 1 of ISO 9735.
01B	Release 2001 - B Message approved and issued in the second 2001 release of the UNTDID (United Nations Trade Data Interchange Directory).
0057	Association assigned code A code assigned by the association responsible for the design and maintenance of the message type concerned, which further identifies the message.
EAN009	GS1 version control number (GS1 Permanent Code) Indicates that the message is an EANCOM message in version 009.
0065	Message type Code identifying a type of message and assigned by its controlling agency. Notes: 1. Type of message being transmitted.

Used Codes

ORDRSP	<p>Purchase order response message A code to identify the purchase order response message. GS1 Description: Message from the seller to the buyer, responding to a purchase order message or a purchase order change request message.</p>
0081	<p>Section identification Separates sections in a message.</p>
S	<p>Detail/summary section separation To qualify the segment UNS, when separating the detail from the summary section of a message.</p>
1001	<p>Document name code Code specifying the document name.</p>
231	<p>Purchase order response Response to an purchase order already received.</p>
1131	<p>Code list identification code Code identifying a user or association maintained code list.</p> <p>Notes: 1. The codes for this data element are provided by the code list responsible agency defined in data element 3055.</p>
23	<p>Clearing house automated payment Self explanatory.</p> <p>Notes: This code value will be removed effective with directory D.04A. GS1 Description: Banking community' automated payment clearing system.</p>
25	<p>Bank identification Code for identification of banks.</p> <p>Notes: This code value will be removed effective with directory D.04A.</p>
106	<p>Incoterms 1980 (4110) Code to indicate applicable Incoterm (1980 edition) under which seller undertakes to deliver merchandise to buyer (ICC). Incoterms 1990: use 4053 only.</p> <p>Notes: This code value will be removed effective with directory D.04A.</p>

Used Codes

132	Charge Identification of a type of charge. Notes: This code value will be removed effective with directory D.04A.
154	Bank branch sorting identification Identification of a specific branch of a bank. Notes: This code value will be removed effective with directory D.04A.
157	Clearing code Identification of the responsible bank/clearing house which has cleared or is ordered to do the clearing. Notes: This code value will be removed effective with directory D.04A.
166	Social security identification Code assigned by the authority competent to issue social security identification to identify a person. Notes: This code value will be removed effective with directory D.04A.
174	Citizen identification Self explanatory. Notes: This code value will be removed effective with directory D.04A. GS1 Description: Code issued by national authority competent to issue citizen identification to identify a person.
1E	Incoterms 1990 (GS1 Temporary Code) Incoterms 1990 as published by the International Chamber of Commerce (ICC).
2E	Incoterms 2000 (GS1 Temporary Code) Incoterms 2000 as published by the International Chamber of Commerce (ICC).
3E	Incoterms 2010 (GS1 Temporary Code) Incoterms 2010 as published by the International Chamber of Commerce (ICC).
ADR	Accord Europeen au transport international dangereuses (GS1 Temporary Code) A European agreement concerning the international carriage of dangerous goods by road.

Used Codes

BR	Brand (GS1 Temporary Code) An identifying mark or label on the products of a particular company, or the kind or make of a commodity.
CA	Category (GS1 Temporary Code) A class or division in a scheme of classification.
CO	Colour (GS1 Temporary Code) Description of the colour required/available on the goods.
FL	Flavor (GS1 Temporary Code) The characteristic quality of goods.
HMT	Hazardous material standard text (GS1 Temporary Code) Code indicating agreed standard text on hazardous materials.
LOC	Location Code (GS1 Temporary Code) This is a code to indicate where the EAS tag is located on the Trade Item. Values include On outside of Trade Item, Concealed inside Trade Item, Integrated Inside Trade Item.
OAG	Organic Claim Agency (GS1 Temporary Code) A governing body that creates and maintain standards related to organic products.
OCO	Organic Trade Item Code (GS1 Temporary Code) Used to indicate the organic status of a trade item or of one or more of its components.
OUM	Ordering unit of measure (GS1 Temporary Code) The alternate Unit of Measure of how Trade Items are ordered by the Retailer under one Unit of Measure, but sold under another Unit of Measure.
SKB	SKRS recommendation (GS1 Temporary Code) SKRS recommendation for standard clothes hanger.
SRN	Service relation number (GS1 Temporary Code) A number used to identify a database entry which records recurring services, e.g., treatment of a patient in a hospital, usage by a member of a library facilities, etc.
ST	Style (GS1 Temporary Code) Specific or characteristic design in any goods.
SUM	Selling unit of measure (GS1 Temporary Code) Describes the measurement used for selling unit of the Trade Item to the end consumer.
SZ	Size (GS1 Temporary Code) Any of a series of graded classifications of measure into which goods are divided.

Used Codes

SZG	Size Group (GS1 Temporary Code) A description of the variable size that is necessary to uniquely specify the size of the item in conjunction with the nonpackaged size dimension.
TYP	Type Code (GS1 Temporary Code) This is a code to indicate the type of EAS tag located on the Trade Item. Values include Acousto-Magnetic, Electro-Magnetic, Ink or dye, Microwave, Radio Frequency.
X11	Diet Allergen (GS1 Temporary Code) Indication of which dietary or allergen marks that are on the package.
X12	Environment (GS1 Temporary Code) Indication of which environmental marks (e.g. recycling schemes) that are on trade item package.
X13	Ethical (GS1 Temporary Code) Indication of which ethical trading marks that are on the package.
X14	Free Form (GS1 Temporary Code) Indication of which free-from marks that are on the package.
X15	Expiration date (GS1 Temporary Code) Indicates the type of expiration date marked on the packaging.
X16	Nesting Direction (GS1 Temporary Code) Depicts the arrangement of two items that nest together specifically whether they nest against each other or on top of each other.
X17	Package Marks Hygienic (GS1 Temporary Code) Indication of which hygiene markings are present in the product package
X18	Hazardous Components are Removable (GS1 Temporary Code) An indicator if any hazardous components contained within the trade item can easily be separated from the other materials to facilitate product recycling.
X19	Trade Item Has Refuse Obligations (GS1 Temporary Code) Indicates if there are special disposal obligations that apply to the trade item for example INTRASTAT.
X20	Trade Item Is Designed for Easy Disassembly (GS1 Temporary Code) Indicates that the trade item is designed for easy disassembly by recycling facilities using standard industry tools.
X21	Trade Item Is Rigid Plastic Packaging Container (GS1 Temporary Code) Indicates that a product is or is contained in a Rigid Plastic Packaging Container (RPPC) as defined by laws in the target market.
X22	Trade Item Is ROHS Compliant (GS1 Temporary Code) Indicates if the product is compliant with the European Union RoHS Directive.
X23	Trade Item Is Universal Waste (GS1 Temporary Code) Indicates if a product can be considered universal waste.

Used Codes

X24	Trade Item Is Consumer Upgradeable Or Maintainable (GS1 Temporary Code) Indicates if a product can be easily upgraded or have parts replaced by the consumer.
X25	Trade Item Contains Short Chain Chlorinated Paraffins (GS1 Temporary Code) Indicate if the trade item and/or its components contain paints, coatings, plastics or other materials containing short chain chlorinated paraffins (SCCPs).
X26	Trade Item Contains Pesticide (GS1 Temporary Code) Indicates if the trade item is advertised or labelled as a chemical or contains a chemical that is advertised or labelled to kill, repel or prevent the growth of any living organism.
X27	Trade Item Contains Propellant (GS1 Temporary Code) Indicates if a trade item contains a compressed gas or propellant.
X28	Trade Item Contains Polyvinyl Chloride (GS1 Temporary Code) Indicate if product contains Polyvinyl Chloride (PVC), a widely used thermoplastic polymer.
X29	Trade Item Chemical Is Not Intended For Human Consumption (GS1 Temporary Code) Indicates that the trade item is or contains a Liquid, Gel, Paste, Powder, or Flammable solid not intended for human consumption (ingested).
X30	ROHS Compliance Failure Material (GS1 Temporary Code) The material used in the trade item that does not comply with the ROHS Directives
X31	Packaging Terms And Condition (GS1 Temporary Code) Indicates if the packaging given in the described packaging configuration is a rented, exchangeable, against deposit or one way/not reusable.
X32	Warranty Effective Date Type (GS1 Temporary Code) The type of date associated with the warranty trade item usually expressed as an event date for the item for example date of purchase, date of manufacture or date of delivery.
X33	Warranty Type (GS1 Temporary Code) Type of warranty available for the part, e.g. labour, distance, extended service.
X35	Warranty Constraint (GS1 Temporary Code) Defines the relationship between different guarantee terms, e.g. "and", "or", "the stronger", "the weaker".
X36	Seasonal Availability End Date (GS1 Temporary Code) Indicates the end date of the trade item's seasonal availability.
X37	Seasonal Availability Start Date (GS1 Temporary Code) Indicates the start date of the trade item's seasonal availability.

Used Codes

X38	Season Calendar Year (GS1 Temporary Code) This element indicates the calendar year in which the trade item is seasonally available.
X39	Season Parameter (GS1 Temporary Code) Indication of the season, in which the trade item is available.
X40	Trade Item Automatic Power Down is Enabled (GS1 Temporary Code) An indicator whether a product is enabled with auto power down feature when shipped to the customer.
X41	Electrical Usage Agency Code (GS1 Temporary Code) The agency that regulates electrical usage for products within a target market.
X42	Nesting Type (GS1 Temporary Code) Depicts whether a nested item fits inside or over the other item in a nesting relationship.
X43	Display Dimension Type Code (GS1 Temporary Code) Depicts certain display scenarios used for measurement.
X44	Manufacturer Has Take Back Program (GS1 Temporary Code) Indicates if the manufacturer of the trade item offers any take back programs to consumers for the product to be reused, remanufactured or recycled by the manufacturer.
X45	Display Resolution (GS1 Temporary Code) The display resolution of a television or computer display.
X46	Orientation Preference Sequence (GS1 Temporary Code) Depicts the preferred sequence of orientation used to communicate the manufacturers relative preferences of orientation.
X47	Orientation Type (GS1 Temporary Code) Depicts via code a display orientation for a trade item.
X48	Electrical Usage Trade Item Classification Code (GS1 Temporary Code) A classification code value from a product classification scheme provided to drive required information for electrical usage.
X49	Electrical Usage Trade Item Classification Name (GS1 Temporary Code) A classification name from a product classification scheme provided to drive required information for electrical usage.
X50	Electrical Usage SubClassification Code (GS1 Temporary Code) A sub-classification code value from a product classification scheme provided to drive required information for electrical usage.
X51	Electrical Usage SubClassification Name (GS1 Temporary Code) A sub-classification name provided to drive required information for electrical usage.

Used Codes

X52	Confirmation Status Code (GS1 Temporary Code) The CIC Confirmation Code must be of a type of code number that can be generated automatically by a computer system.
X53	Confirmation Status Code Description (GS1 Temporary Code) Provides the code description that matches up with the Code that can possibly be generated automatically by a computer system.
X54	Additional Confirmation Status Description (GS1 Temporary Code) Provides a way to communicate human entered information that may not be covered by the machine to machine codes and descriptions.
X55	Corrective Action (GS1 Temporary Code) Provides the corrective action code to fix the issue that caused the problem.
X56	Expected Corrective Information (GS1 Temporary Code) Provides the expected corrective information via a human entered information that may not be covered by the machine to machine codes.
X57	Electrical Usage Trade Item Classification Agency (GS1 Temporary Code) A classification agency or organisation whose product classification scheme is being provided to drive required information for electrical usage.
X58	ASFIS (GS1 Permanent Code) FAO alphah-3 code list for fish species identification, commercial name & scientific name.
X59	FAO fishing areas (GS1 Permanent Code) FAO fishing areas codelist.
X60	FAO Fishing gear type (GS1 Permanent Code) FAO Fishing gear type codelist.
X61	EU fish quality (GS1 Permanent Code) EU fish quality grade code list (E, A, B, C).
X62	EU fish size (GS1 Permanent Code) EU fish standardized size code list (1, 2, 3, 4, 5 & One_Size).
X63	EU fish presentation (GS1 Permanent Code) EU fish presentation code list (3 or 5 char alpha code).
ZZZ	Mutually defined Self explanatory. Note : This code value will be removed effective with directory D.04A.
BOEV	BOEV (fix value)
MEDIA	Media (fix value)
1153	Reference code qualifier Code qualifying a reference.

Used Codes

AXO	Product certification number Number assigned by a governing body (or their agents) to a product which certifies compliance with a standard. GS1 Note: Replaces GS1 Temporary Code XC1.
CR	Customer reference number Reference number assigned by the customer to a transaction.
GN	Government reference number A number that identifies a government reference. GS1 Description: This code value should not be used to provide the tax identification number for a party (use code VA).
IT	Internal customer number Number assigned by a seller, supplier etc. to identify a customer within his enterprise.
LI	Line item reference number (1156) Reference number identifying a particular line in a document.
ON	Order number (buyer) [1022] Reference number assigned by the buyer to an order.
PD	Promotion deal number Number assigned by a vendor to a special promotion activity.
SD	Sales department number A number that identifies a sales department.
SS	Seller's reference number Reference number assigned to a transaction by the seller.
VA	VAT registration number Unique number assigned by the relevant tax authority to identify a party for use in relation to Value Added Tax (VAT).
VN	Order number (supplier) Reference number assigned by supplier to a buyer's purchase order.
YC1	Additional party identification (GS1 Temporary Code) Reference number to an additional party identification. This number may be the internal trading partner identification number used by a party to identify its trading parties.
1225	Message function code Code indicating the function of the message.

Used Codes

4	Change Message containing items to be changed. GS1 Description: Message containing items (e.g. line items, goods items, customs items, equipment items) to be changed in a previously sent message or an existing data base.
27	Not accepted Message to inform that the referenced message is not accepted by the recipient.
29	Accepted without amendment Referenced message is entirely accepted.
1229	Action request/notification description code Code specifying the action to be taken or already taken.
1	Added The information is to be or has been added. GS1 Description: This line item is added to a referenced message or an existing data base.
2	Deleted The information is to be or has been deleted. GS1 Description: This line item is deleted from a referenced message or an existing data base.
3	Changed The information is to be or has been changed. GS1 Description: This line item is changed in a referenced message or an existing data base. A change to data on a data base would normally result in the creation of a history entry recording the correction.
4	No action This line item is not affected by the actual message.
5	Accepted without amendment This line item is entirely accepted by the seller.
6	Accepted with amendment This line item is accepted but amended by the seller.
7	Not accepted This line item is not accepted by the seller.
10	Not found This line item is not found in the referenced message.
11	Not amended This line is not amended by the buyer.

Used Codes

23	Proposed amendment A code used to indicate an amendment suggested by the sender.
24	Accepted with amendment, no confirmation required Accepted with changes which require no confirmation.
38	Replaced Provide a replacement.
55	Referred item, rejected The item being referred to has been rejected.
74	Reopened Opened again. GS1 Description: A line item that was marked for deletion is reactivated in the referenced message or existing database.
96	Correction of error A correction to information previously communicated which contained an error.
115	Prior addition This existing line item becomes available at an earlier date. A line item, which has already been added with a certain start validity date is added again with a validity date prior to that of the last addition in the referenced message or existing database.
11E	Reporting item details included (SWIFT Code) Reporting item details are included.
12E	No advice (SWIFT Code) No details will be advised.
13E	Reporting item details sent separately (SWIFT Code) Reporting item details have been transmitted separately.
14E	Reporting item details to follow (SWIFT Code) Reporting item details will be sent separately.
XB6	Reporting item details advised just-in-time (SWIFT Code) Reporting item details will be advised just-in-time.
2005	Date or time or period function code qualifier Code qualifying the function of a date, time or period.
2	Delivery date/time, requested Date on which buyer requests goods to be delivered.
11	Despatch date and/or time (2170) Date/time on which the goods are or are expected to be despatched or shipped.

Used Codes

44	Availability Date/time when received item is available.
61	Cancel if not delivered by this date The date on which cancellation should take place, if delivery has not occurred.
63	Delivery date/time, latest Date identifying a point of time after which goods shall not or will not be delivered.
64	Delivery date/time, earliest Date identifying a point in time before which the goods shall not be delivered.
67	Delivery date/time, current schedule Delivery Date deriving from actual schedule.
137	Document/message date/time (2006) Date/time when a document/message is issued. This may include authentication.
171	Reference date/time Date/time on which the reference was issued.
209	Value date Date on which the funds are at the disposal of the beneficiary or cease to be at the disposal of the ordering customer.
364	Minimum shelf life remaining at time of despatch period Period indicating the minimum shelf life remaining for a product at the time of leaving the supplier.
2009	Terms time relation code Code relating terms to a reference date, time or period.
1	Reference date Payment terms related to reference date.
2	Before reference Payment terms related to time before reference date.
3	After reference Payment terms related to time after reference date.
4	End of 10-day period containing the reference date Payment terms are at the end of the ten day period containing the reference date.
5	End of 2-week period containing the reference date Payment terms are at the end of the two week period containing the reference date.
6	End of month containing the reference date Payment terms are at the end of the month containing the reference date.

Used Codes

7	End of the month following the month of reference date Payment terms are at the end of the month following the month of reference date.
8	End of quarter containing the reference date Payment terms are at the end of the quarter containing the reference date.
9	End of year containing the reference date Payment terms are at the end of the year containing the reference date.
10	End of week containing the reference date Payment terms are at the end of the week containing the reference date.
11	End of ten day period following month after reference date's month Payment terms are 10 days after the end of the referenced month.
14	End of 15-day period containing the reference date Payment terms are at the end of the 15-day period containing the reference date.
16	Whichever is first, the 15th or last day of the month following the payment terms period The payment terms are at, whichever is first, the 15th or the last day of the month following the payment terms period (payment terms period = period of time between the reference date and the theoretical due date).
17	After end of month containing the reference date Payment terms related to a time after the end of the month containing the reference date.
2151	Period type code Code specifying the type of period.
D	Day The twenty-four hour period during which the earth completes one rotation on its axis.
2379	Date or time or period format code Code specifying the representation of a date, time or period.
2	DDMMYY Calendar date: D = Day; M = Month; Y = Year.
101	YYMMDD Calendar date: Y = Year; M = Month; D = Day.
102	CCYYMMDD Calendar date: C = Century ; Y = Year ; M = Month ; D = Day.

Used Codes

104	MMWW-MMWW A period of time specified by giving the start week of a month followed by the end week of a month. Data is to be transmitted as consecutive characters without hyphen.
107	DDD Day's number within a specific year: D = Day.
108	WW Week's number within a specific year: W = Week.
109	MM Month's number within a specific year: M = Month.
110	DD Day's number within is a specific month.
201	YYMMDDHHMM Calendar date including time without seconds: Y = Year; M = Month; D = Day; H = Hour; M = Minute.
203	CCYYMMDDHHMM Calendar date including time with minutes: C=Century; Y=Year; M=Month; D=Day; H=Hour; M=Minutes.
204	CCYYMMDDHHMMSS Calendar date including time with seconds: C=Century;Y=Year; M=Month; D=Day;H=Hour;M=Minute;S=Second.
401	HHMM Time without seconds: H = Hour; m = Minute.
501	HHMMHHMM Time span without seconds: H = Hour; m = Minute;.
502	HHMMSS-HHMMSS Format of period to be given without hyphen.
602	CCYY Calendar year including century: C = Century; Y = Year.
609	YYMM Month within a calendar year: Y = Year; M = Month.
610	CCYYMM Month within a calendar year: CC = Century; Y = Year; M = Month.
615	YYWW Week within a calendar year: Y = Year; W = Week 1st week of January = week 01.
616	CCYYWW Week within a calendar year: CC = Century; Y = Year; W = Week (1st week of January = week 01).

Used Codes

713	YYMMDDHHMM-YYMMDDHHMM Format of period to be given in actual message without hyphen.
715	YYWW-YYWW A period of time specified by giving the start week of a year followed by the end week of year (both not including century). Data is to be transmitted as consecutive characters without hyphen.
717	YYMMDD-YYMMDD Format of period to be given in actual message without hyphen.
718	CCYYMMDD-CCYYMMDD Format of period to be given without hyphen.
719	CCYYMMDDHHMM-CCYYMMDDHHMM A period of time which includes the century, year, month, day, hour and minute. Format of period to be given in actual message without hyphen.
720	DHHMM-DHHMM Format of period to be given without hyphen (D=day of the week, 1=Monday; 2=Tuesday; ... 7=Sunday).
801	Year To indicate a quantity of years.
802	Month To indicate a quantity of months.
803	Week To indicate a quantity of weeks.
804	Day To indicate a quantity of days.
805	Hour To indicate a quantity of hours.
806	Minute To indicate a quantity of minutes.
810	Trimester To indicate a quantity of trimesters (three months).
811	Half month To indicate a quantity of half months.
21E	DDHHMM-DDHHMM (GS1 Temporary Code) Format of period to be given in actual message without hyphen.
2475	Time reference code Code referencing a point in time.

Used Codes

1	Date of order Payment time reference is date of order.
2	Date of confirmation Payment time reference is date of confirmation.
3	Date of contract Payment time reference is date of contract.
5	Date of invoice Payment time reference is date of invoice.
6	Date of credit note Payment time reference is date of credit note.
7	Date of present document Payment time reference is date of present document.
8	Date of confirmation of order received Payment time reference is date of confirmation received.
9	Date invoice received Payment time reference is date of invoice received.
11	Date credit note received Payment time reference is date of credit note received.
12	Date present document received Payment time reference is date of present document received.
21	Date goods received by buyer Payment time reference is date when goods are received by buyer.
23	Date goods received by carrier Payment time reference is date when goods are received by carrier.
26	Date of arrival of transport Date the transport arrived at the agreed destination.
27	Date of outward frontier crossing Date the goods are crossing the border of the exporters country.
28	Date of inward frontier crossing Date the goods are crossing the border of the importers country.
29	Date of delivery of goods to establishments/domicile/site Date the goods are delivered at agreed place of destination.
52	Due date of negotiable instrument Date when the negotiable instrument is due for payment.
66	Specified date Date specified elsewhere.

Used Codes

67	Anticipated delivery date The date on which delivery is anticipated to take place.
68	Effective date The date on which an action or event becomes effective.
69	Invoice transmission date Payment time reference is the date of invoice transmission.
70	Date of issue of transport document(s) The date on which a transport document(s) is issued.
72	Payment date Date when a payment was made.
78	Customs clearance date (import) Date when goods clear Customs in the importing country.
79	Customs clearance date (export) Date when goods clear Customs in the exporting country.
80	Date of salary payment Date when a salary payment was made.
81	Date of shipment as evidenced by the transport document(s) Date of shipment as evidenced by the transport document(s).
83	Requested date of delivery Payment terms apply from the requested date of delivery.
83E	Period of exceptional situation (GS1 Temporary Code) Period of a situation that affects the normal contribution of the employee.
X10	Receipt of goods (GS1 Temporary Code) Payment time reference is the date when goods are received by a receiving party.
3035	Party function code qualifier Code giving specific meaning to a party.
BY	Buyer Party to whom merchandise and/or service is sold.
DP	Delivery party (3144) Party to which goods should be delivered, if not identical with consignee. GS1 Description: Party to which goods should be delivered, if not the same as the buyer.
GZ	Substitute supplier Party which may be in a position to supply products or services should the main usual supplier be unable to do so.

Used Codes

IV	Invoicee (3006) Party to whom an invoice is issued.
PW	Despatch party (3282) Party where goods are collected or taken over by the carrier (i.e. if other than consignor).
SU	Supplier Party who supplies goods and/or services. GS1 Description: Party which provides service(s) and/or manufactures or otherwise has possession of goods, and consigns or makes them available in trade.
UC	Ultimate consignee Party who has been designated on the invoice or packing list as the final recipient of the stated merchandise.
3055	Code list responsible agency code Code specifying the agency responsible for a code list.
2	CEC (Commission of the European Communities) Generic: see also 140, 141, 142, 162. GS1 Description: Commission of the European Communities
3	IATA (International Air Transport Association) The airline industry's international organisation. GS1 Description: International Air Transport Association
5	ISO (International Organization for Standardization) International Organization of Standardization.
6	UN/ECE (United Nations - Economic Commission for Europe) United Nations Economic Commission for Europe.
7	CEFIC (Conseil Europeen des Federations de l'Industrie Chimique) EDI project for chemical industry.
8	EDIFICE Standardised electronic commerce forum for companies with interests in computing, electronics and telecommunications. GS1 Description: EDI Forum for companies with Interest in Computing and Electronics (EDI project for EDP/ADP sector).
9	GS1 GS1 (formerly EAN International), an organisation of GS1 Member Organisations, which manages the GS1 System. GS1 Description: GS1 International.

Used Codes

10	ODETTE Organization for Data Exchange through Tele-Transmission in Europe (European automotive industry project).
17	S.W.I.F.T. Society for Worldwide Interbank Financial Telecommunications s.c.
28	EDITEUR (European book sector electronic data interchange group) Code identifying the pan European user group for the book industry as an organisation responsible for code values in the book industry.
60	Assigned by national trade agency The code list is from a national agency.
65	GS1 France Organisation responsible for GS1 System in France.
68	GS1 Italy Organisation responsible for GS1 System in Italy.
83	US, National Retail Federation The National Retail Federation is the trade association for the general merchandise retailing industry. In addition to providing support and education services, they also maintain and publish standard colour and size codes for the retail industry.
84	DE, BRD (Gesetzgeber der Bundesrepublik Deutschland) German legislature.
86	Assigned by party originating the message Codes assigned by the party originating the message.
87	Assigned by carrier Codes assigned by the carrier.
88	Assigned by owner of operation Assigned by owner of operation (e.g. used in construction).
89	Assigned by distributor Codes assigned by a distributor.
90	Assigned by manufacturer Code assigned by the manufacturer.
91	Assigned by supplier or supplier's agent Codes assigned by a seller or seller's agent. GS1 Description: Code assigned by the supplier or supplier's agent.
92	Assigned by buyer or buyer's agent Codes assigned by a buyer or buyer's agent.
112	US, U.S. Census Bureau The Bureau of the Census of the U.S. Dept. of Commerce.

Used Codes

113	GS1 US Organisation responsible for GS1 System in the USA.
116	US, ANSI ASC X12 American National Standards Institute ASC X12.
131	DE, German Bankers Association German Bankers' Association.
136	GS1 UK Organisation responsible for GS1 System in the UK.
137	AT, Verband oesterreichischer Banken und Bankiers Austrian bankers association.
174	DE, DIN (Deutsches Institut fuer Normung) German standardization institute.
182	US, Standard Carrier Alpha Code (Motor) Organisation maintaining the SCAC lists and transportation operating in North America.
194	AU, AQIS (Australian Quarantine and Inspection Service) Australian Quarantine and Inspection Service.
200	GS1 Netherlands Organisation responsible for GS1 System in the Netherlands.
245	GS1 Denmark Organisation responsible for GS1 System in Denmark.
246	GS1 Germany Organisation responsible for GS1 System in Germany. GS1 Description: German representative of International Article Numbering association (GS1).
260	Ediel Nordic forum A code to identify Ediel Nordic forum, which is an organization standardizing the use of EDI between the participants in the Nordic power market.
281	GS1 Belgium & Luxembourg Organisation responsible for GS1 System in Belgium & Luxembourg.
286	SE, TCO (Tjänstemännens Central Organisation) The Swedish Confederation of Professional Employees.
294	GS1 Austria Organisation responsible for the GS1 System in Austria.
295	AU, Therapeutic Goods Administration Austrialian administration responsible for the regulation of therapeutic goods in Australia. EDIFACT

Used Codes

297	IT, Ufficio IVA Ufficio responsabile gestione partite IVA, Italy (Italian Institute issuing VAT registration numbers). EDIFACT
298	GS1 Spain Organisation responsible for the GS1 System in Spain.
316	GS1 Finland Organisation responsible for the GS1 system in Finland.
317	GS1 Brazil Organisation responsible for the GS1 system in Brazil.
324	GS1 Ireland Organisation responsible for the GS1 system in Ireland.
325	GS1 Russia Organisation responsible for the GS1 system in Russia.
326	GS1 Poland Organisation responsible for the GS1 system in Poland.
327	GS1 Estonia Organisation responsible for the GS1 system in Estonia.
376	PANTONE Color code controlling organisation
400	FAO (Food and Agriculture Organisation) Food and Agriculture Organisation of the United Nations.
403	Comite Europeen de Normalisation Comite Européen de Normalisation (CEN), European committee for standardisation. GS1 Note: Replaces GS1 Temporary Code CEN.
404	Assigned by logistics service provider Codes assigned by a logistics service provider. GS1 Note: Replaces GS1 Temporary Code X6.
CEN	Comite European de Normalisation (GS1 Temporary Code) Comite European de Normalisation. GS1 Note: Code marked for deletion. Use value 403 instead.
PMS	Pantone Matching System (GS1 Temporary Code) Pantone Matching System.
RAL	DE, Deutsches Institut fuer Guetesicherung und Kennzeichnung (GS1 Temporary Code) German Institute for Quality Assurance and Certification.

Used Codes

X5	IT, Ufficio IVA (GS1 Temporary Code) Ufficio responsabile gestione partite IVA, Italy (Italian Institute issuing VAT registration numbers).
X6	Assigned by logistics service provider (GS1 Temporary Code) Codes assigned by the logistics service provider. GS1 Note: Code marked for deletion. Use value 404 instead.
ZZZ	Mutually defined A code assigned within a code list to be used on an interim basis and as defined among trading partners until a precise code can be assigned to the code list.
3139	Contact function code Code specifying the function of a contact (e.g. department or person).
AA	Insurance contact Department/person to contact for matters regarding insurance.
AD	Accounting contact The contact responsible for accounting matters.
AE	Contract contact Department/person to contact for matters regarding contracts.
AM	Claims contact Department/person to contact for matters regarding claims.
AP	Accounts payable contact Department/person responsible for the accounts payable function within a corporation.
AR	Accounts receivable contact Department/person responsible for the accounts receivable within a corporation.
BC	Banking contact Contact person for bank.
BJ	Department or person responsible for processing purchase order Identification of the department or person responsible for the processing of purchase orders.
BN	Certification contact Code specifying a contact with knowledge of a certification action.
BO	After business hours contact Department/person to contact after normal working hours.
BR	Cook Person responsible for cooking. GS1 Note: Replaces GS1 Temporary Code CKE.

Used Codes

CB	Changed by Person who made the change.
CKE	Cook (GS1 Temporary Code) Person responsible for cooking. GS1 Note: Code marked for deletion. Use value BR instead.
CN	Consignee (3132) Party to which goods are consigned.
CO	Consignor (3336) Party which, by contract with a carrier, consigns or sends goods with the carrier, or has them conveyed by him. Synonym: shipper/sender.
CP	Responsible person for computer data processing Responsible person to contact for matters regarding computer data processing.
CR	Customer relations Individual responsible for customer relations.
DE	Department/employee to execute export procedures Department/employee which/who executes export procedures.
DI	Department/employee to execute import procedures Department/employee which/who executes import procedures.
DL	Delivery contact Department/person responsible for delivery.
ED	Engineering contact Department/person to contact for matters regarding engineering.
GR	Goods receiving contact Department/person responsible for receiving the goods at the place of delivery.
HE	Emergency dangerous goods contact Party who is to be contacted to intervene in case of emergency.
HG	Dangerous goods contact Department/person to be contacted for details about the transportation of dangerous goods/hazardous material.
IC	Information contact Department/person to contact for questions regarding transactions.
LO	Place of collection contact Department/employee to be contacted at the place of collection.
MGR	Manager (GS1 Temporary Code) Person responsible for management within a department or company.
NT	Notification contact Department/employee to be notified.

Used Codes

OC	Order contact An individual to contact for questions regarding this order.
PD	Purchasing contact Department/person responsible for issuing this purchase order.
PM	Product management contact Department/person to contact for questions regarding this order.
QC	Quality coordinator contact Quality coordinator contact within an organization.
SA	Sales administration Name of the sales administration contact within a corporation.
SD	Shipping contact The shipping department contact within an organization.
SR	Sales representative or department The sales representative or department contact within an organization.
TA	Traffic administrator The traffic administrator contact within an organization.
TD	Test contact Department/person responsible for testing contact.
TR	Transport contact Department/person in charge of transportation.
WH	Warehouse The warehouse contact within an organization.
3155	Communication address code qualifier Code qualifying the communication address.
AL	Cellular phone Identifies the cellular phone number.
AO	Uniform Resource Location (URL) Identification of the Uniform Resource Location (URL) Synonym: World wide web address. EDIFACT
AQ	X.400 address for mail text The X.400 address accepting information in the body text of a message.
AR	AS1 address Address capable of receiving messages in accordance with the EDIINT/AS1 protocol for MIME based EDI .

Used Codes

AS	AS2 address Address capable of receiving messages in accordance with the EDIINT/AS2 protocol.
AT	AS3 address Address capable of receiving messages in accordance with the EDIINT/AS3 protocol.
AU	File Transfer Protocol Address capable for receiving message in accordance with the File Transfer Protocol (IETF RFC 959 et. al.).
CA	Cable address The communication number identifies a cable address.
EI	EDI Number identifying the service and service user.
EM	Electronic mail Exchange of mail by electronic means. GS1 Description: Creating/sending/receiving of unstructured free text messages or documents using computer network, a mini-computer or an attached modem and regular telephone line or other electronic transmission media.
EXI	Exite mail (GS1 Temporary Code) Requests that the file shall be returned via Exite. GS1 Note: Code marked for deletion.
FX	Fax Device used for transmitting and reproducing fixed graphic material (as printing) by means of signals over telephone lines or other electronic transmission media.
IA	Interchange address (GS1 Temporary Code) Code identifying an EDI interchange address.
TE	Telephone Voice/data transmission by telephone.
TL	Telex Transmission of text/data via telex.
XF	X.400 The X.400 address. GS1 Description: CCITT Message handling system.
XG	Pager Identifies that the communication number is for a pager.

Used Codes

3207

Country name code

| Identification of the name of the country or other geographical entity as defined in ISO 3166-1.

Notes:

| 1. Use ISO 3166-1 two alpha country code.

AD	ANDORRA
AE	UNITED ARAB EMIRATES
AF	AFGHANISTAN
AG	ANTIGUA AND BARBUDA
AI	ANGUILLA
AL	ALBANIA
AM	ARMENIA
AO	ANGOLA
AQ	ANTARCTICA
AR	ARGENTINA
AS	AMERICAN SAMOA
AT	AUSTRIA
AU	AUSTRALIA
AW	ARUBA
AX	ÅLAND ISLANDS
AZ	AZERBAIJAN
BA	BOSNIA AND HERZEGOVINA
BB	BARBADOS
BD	BANGLADESH
BE	BELGIUM
BF	BURKINA FASO
BG	BULGARIA
BH	BAHRAIN
BI	BURUNDI
BJ	BENIN
BL	SAINT BARTHÉLEMY
BM	BERMUDA
BN	BRUNEI DARUSSALAM
BO	BOLIVIA (PLURINATIONAL STATE OF)

Used Codes

BQ	BONAIRE, SINT EUSTATIUS AND SABA
BR	BRAZIL
BS	BAHAMAS
BT	BHUTAN
BV	BOUVET ISLAND
BW	BOTSWANA
BY	BELARUS
BZ	BELIZE
CA	CANADA
CC	COCOS (KEELING) ISLANDS
CD	CONGO, DEMOCRATIC REPUBLIC OF THE
CF	CENTRAL AFRICAN REPUBLIC
CG	CONGO
CH	SWITZERLAND
CI	COTE D'IVOIRE
CK	COOK ISLANDS
CL	CHILE
CM	CAMEROON
CN	CHINA
CO	COLOMBIA
CR	COSTA RICA
CU	CUBA
CV	CABO VERDE
CW	CURAÇAO
CX	CHRISTMAS ISLAND
CY	CYPRUS
CZ	CZECHIA
DE	GERMANY
DJ	DJIBOUTI
DK	DENMARK
DM	DOMINICA
DO	DOMINICAN REPUBLIC
DZ	ALGERIA

Used Codes

EC	ECUADOR
EE	ESTONIA
EG	EGYPT
EH	WESTERN SAHARA
ER	ERITREA
ES	SPAIN
ET	ETHIOPIA
FI	FINLAND
FJ	FIJI
FK	FALKLAND ISLANDS (MALVINAS)
FM	MICRONESIA (FEDERATED STATES OF)
FO	FAROE ISLANDS
FR	FRANCE
GA	GABON
GB	UNITED KINGDOM OF GREAT BRITAIN AND NORTHERN IRELAND
GD	GRENADA
GE	GEORGIA
GF	FRENCH GUIANA
GG	GUERNSEY
GH	GHANA
GI	GIBRALTAR
GL	GREENLAND
GM	GAMBIA
GN	GUINEA
GP	GUADELOUPE
GQ	EQUATORIAL GUINEA
GR	GREECE
GS	SOUTH GEORGIA AND THE SOUTH SANDWICH ISLANDS
GT	GUATEMALA
GU	GUAM
GW	GUINEA-BISSAU
GY	GUYANA
HK	HONG KONG

Used Codes

HM	HEARD ISLAND AND MCDONALD ISLANDS
HN	HONDURAS
HR	CROATIA
HT	HAITI
HU	HUNGARY
ID	INDONESIA
IE	IRELAND
IL	ISRAEL
IM	ISLE OF MAN
IN	INDIA
IO	BRITISH INDIAN OCEAN TERRITORY
IQ	IRAQ
IR	IRAN (ISLAMIC REPUBLIC OF)
IS	ICELAND
IT	ITALY
JE	JERSEY
JM	JAMAICA
JO	JORDAN
JP	JAPAN
KE	KENYA
KG	KYRGYZSTAN
KH	CAMBODIA
KI	KIRIBATI
KM	COMOROS
KN	SAINT KITTS AND NEVIS
KP	KOREA (DEMOCRATIC PEOPLE'S REPUBLIC OF)
KR	KOREA, REPUBLIC OF
KW	KUWAIT
KY	CAYMAN ISLANDS
KZ	KAZAKHSTAN
LA	LAO PEOPLE'S DEMOCRATIC REPUBLIC
LB	LEBANON
LC	SAINT LUCIA

Used Codes

LI	LIECHTENSTEIN
LK	SRI LANKA
LR	LIBERIA
LS	LESOTHO
LT	LITHUANIA
LU	LUXEMBOURG
LV	LATVIA
LY	LIBYA
MA	MOROCCO
MC	MONACO
MD	MOLDOVA, REPUBLIC OF
ME	MONTENEGRO
MF	SAINT MARTIN (FRENCH PART)
MG	MADAGASCAR
MH	MARSHALL ISLANDS
MK	NORTH MACEDONIA
ML	MALI
MM	MYANMAR
MN	MONGOLIA
MO	MACAO
MP	NORTHERN MARIANA ISLANDS
MQ	MARTINIQUE
MR	MAURITANIA
MS	MONTSERRAT
MT	MALTA
MU	MAURITIUS
MV	MALDIVES
MW	MALAWI
MX	MEXICO
MY	MALAYSIA
MZ	MOZAMBIQUE
NA	NAMIBIA
NC	NEW CALEDONIA

Used Codes

NE	NIGER
NF	NORFOLK ISLAND
NG	NIGERIA
NI	NICARAGUA
NL	NETHERLANDS
NO	NORWAY
NP	NEPAL
NR	NAURU
NU	NIUE
NZ	NEW ZEALAND
OM	OMAN
PA	PANAMA
PE	PERU
PF	FRENCH POLYNESIA
PG	PAPUA NEW GUINEA
PH	PHILIPPINES
PK	PAKISTAN
PL	POLAND
PM	SAINT PIERRE AND MIQUELON
PN	PITCAIRN
PR	PUERTO RICO
PS	PALESTINE, STATE OF
PT	PORTUGAL
PW	PALAU
PY	PARAGUAY
QA	QATAR
RE	REUNION
RO	ROMANIA
RS	SERBIA
RU	RUSSIAN FEDERATION
RW	RWANDA
SA	SAUDI ARABIA
SB	SOLOMON ISLANDS

Used Codes

SC	SEYCHELLES
SD	SUDAN
SE	SWEDEN
SG	SINGAPORE
SH	SAINT HELENA, ASCENSION AND TRISTAN DA CUNHA
SI	SLOVENIA
SJ	SVALBARD AND JAN MAYEN
SK	SLOVAKIA
SL	SIERRA LEONE
SM	SAN MARINO
SN	SENEGAL
SO	SOMALIA
SR	SURINAME
SS	SOUTH SUDAN
ST	SAO TOME AND PRINCIPE
SV	EL SALVADOR
SX	SINT MAARTEN (DUTCH PART)
SY	SYRIAN ARAB REPUBLIC
SZ	ESWATINI
TC	TURKS AND CAICOS ISLANDS
TD	CHAD
TF	FRENCH SOUTHERN TERRITORIES
TG	TOGO
TH	THAILAND
TJ	TAJKISTAN
TK	TOKELAU
TL	TIMOR-LESTE
TM	TURKMENISTAN
TN	TUNISIA
TO	TONGA
TR	TURKEY
TT	TRINIDAD AND TOBAGO
TV	TUVALU

Used Codes

TW	TAIWAN, PROVINCE OF CHINA
TZ	TANZANIA, UNITED REPUBLIC OF
UA	UKRAINE
UG	UGANDA
UM	UNITED STATES MINOR OUTLYING ISLANDS
US	UNITED STATES OF AMERICA
UY	URUGUAY
UZ	UZBEKISTAN
VA	HOLY SEE
VC	SAINT VINCENT AND THE GRENADINES
VE	VENEZUELA (BOLIVARIAN REPUBLIC OF)
VG	VIRGIN ISLANDS, BRITISH
VI	VIRGIN ISLANDS, U.S.
VN	VIET NAM
VU	VANUATU
WF	WALLIS AND FUTUNA
WS	SAMOA
YE	YEMEN
YT	MAYOTTE
ZA	SOUTH AFRICA
ZM	ZAMBIA
ZW	ZIMBABWE

3227

Location function code qualifier
Code identifying the function of a location.

301

Location of meter
The identification of the location of a meter.
GS1 Note: Replaces GS1 Temporary Code 17E.

3453

Language name code
Code specifying the language name.

Notes:
1. Use ISO 639-1988.

AA

Afar

aa

Afar

Used Codes

AB	Abkhazian
ab	Abkhazian
AE	Avestan
ae	Avestan
AF	Afrikaans
af	Afrikaans
AK	Akan
ak	Akan
AM	Amharic
am	Amharic
AN	Aragonese
an	Aragonese
AR	Arabic
ar	Arabic
AS	Assamese
as	Assamese
AV	Avaric
av	Avaric
AY	Aymara
ay	Aymara
AZ	Azerbaijani
az	Azerbaijani
BA	Bashkir
ba	Bashkir
BE	Belarusian
be	Belarusian
BG	Bulgarian
bg	Bulgarian
BH	Bihari
bh	Bihari
BI	Bislama
bi	Bislama
BM	Bambara

Used Codes

bm	Bambara
BN	Bengali
bn	Bengali
BO	Tibetan
bo	Tibetan
BR	Breton
br	Breton
BS	Bosnian
bs	Bosnian
CA	Catalan; Valencian
ca	Catalan; Valencian
CE	Chechen
ce	Chechen
CH	Chamorro
ch	Chamorro
CO	Corsican
co	Corsican
CR	Cree
cr	Cree
CS	Czech
cs	Czech
CU	Church Slavic; Old Slavonic; Church Slavonic; Old Bulgarian; Old Church Slavonic
cu	Church Slavic; Old Slavonic; Church Slavonic; Old Bulgarian; Old Church Slavonic
CV	Chuvash
cv	Chuvash
CY	Welsh
cy	Welsh
DA	Danish
da	Danish
DE	German
de	German
DV	Divehi; Dhivehi; Maldivian

Used Codes

dv	Divehi; Dhivehi; Maldivian
DZ	Dzongkha
dz	Dzongkha
EE	Ewe
ee	Ewe
EL	Greek; Modern (1453-)
el	Greek; Modern (1453-)
EN	English
en	English
EO	Esperanto
eo	Esperanto
ES	Spanish; Castilian
es	Spanish; Castilian
ET	Estonian
et	Estonian
EU	Basque
eu	Basque
FA	Persian
fa	Persian
FF	Fulah
ff	Fulah
FI	Finnish
fi	Finnish
FJ	Fijian
fj	Fijian
FO	Faroese
fo	Faroese
FR	French
fr	French
FY	Western Frisian
fy	Western Frisian
GA	Irish
ga	Irish

Used Codes

GD	Gaelic; Scottish Gaelic
gd	Gaelic; Scottish Gaelic
GL	Galician
gl	Galician
GN	Guarani
gn	Guarani
GU	Gujarati
gu	Gujarati
GV	Manx
gv	Manx
HA	Hausa
ha	Hausa
HE	Hebrew
he	Hebrew
HI	Hindi
hi	Hindi
HO	Hiri Motu
ho	Hiri Motu
HR	Croatian
hr	Croatian
HT	Haitian; Haitian Creole
ht	Haitian; Haitian Creole
HU	Hungarian
hu	Hungarian
HY	Armenian
hy	Armenian
HZ	Herero
hz	Herero
IA	Interlingua (International Auxiliary Language Association)
ia	Interlingua (International Auxiliary Language Association)
ID	Indonesian
id	Indonesian
IE	Interlingue

Used Codes

ie	Interlingue
IG	Igbo
ig	Igbo
II	Sichuan Yi
ii	Sichuan Yi
IK	Inupiaq
ik	Inupiaq
IO	Ido
io	Ido
IS	Icelandic
is	Icelandic
IT	Italian
it	Italian
IU	Inuktiut
iu	Inuktiut
JA	Japanese
ja	Japanese
JV	Javanese
jv	Javanese
KA	Georgian
ka	Georgian
KG	Kongo
kg	Kongo
KI	Kikuyu; Gikuyu
ki	Kikuyu; Gikuyu
KJ	Kuanyama; Kwanyama
kj	Kuanyama; Kwanyama
KK	Kazakh
kk	Kazakh
KL	Kalaallisut; Greenlandic
kl	Kalaallisut; Greenlandic
KM	Central Khmer
km	Central Khmer

Used Codes

KN	Kannada
kn	Kannada
KO	Korean
ko	Korean
KR	Kanuri
kr	Kanuri
KS	Kashmiri
ks	Kashmiri
KU	Kurdish
ku	Kurdish
KV	Komi
kv	Komi
KW	Cornish
kw	Cornish
KY	Kirghiz; Kyrgyz
ky	Kirghiz; Kyrgyz
LA	Latin
la	Latin
LB	Luxembourgish; Letzeburgesch
lb	Luxembourgish; Letzeburgesch
LG	Ganda
lg	Ganda
LI	Limburgan; Limburger; Limburgish
li	Limburgan; Limburger; Limburgish
LN	Lingala
ln	Lingala
LO	Lao
lo	Lao
LT	Lithuanian
lt	Lithuanian
LU	Luba-Katanga
lu	Luba-Katanga
LV	Latvian

Used Codes

lv	Latvian
MG	Malagasy
mg	Malagasy
MH	Marshallese
mh	Marshallese
MI	Maori
mi	Maori
MK	Macedonian
mk	Macedonian
ML	Malayalam
ml	Malayalam
MN	Mongolian
mn	Mongolian
MO	Moldavian; Moldovan
mo	Moldavian; Moldovan
MR	Marathi
mr	Marathi
MS	Malay
ms	Malay
MT	Maltese
mt	Maltese
MY	Burmese
my	Burmese
NA	Nauru
na	Nauru
NB	Bokmal Norwegian; Norwegian Bokmal
nb	Bokmal Norwegian; Norwegian Bokmal
ND	Ndebele; North; North Ndebele
nd	Ndebele; North; North Ndebele
NE	Nepali
ne	Nepali
NG	Ndonga
ng	Ndonga

Used Codes

NL	Dutch; Flemish
nl	Dutch; Flemish
NN	Norwegian Nynorsk; Nynorsk, Norwegian
nn	Norwegian Nynorsk; Nynorsk, Norwegian
NO	Norwegian
no	Norwegian
NR	Ndebele; South; South Ndebele
nr	Ndebele; South; South Ndebele
NV	Navajo; Navaho
nv	Navajo; Navaho
NY	Chichewa; Chewa; Nyanja
ny	Chichewa; Chewa; Nyanja
OC	Occitan (post 1500); Provencal
oc	Occitan (post 1500); Provencal
OJ	Ojibwa
oj	Ojibwa
OM	Oromo
om	Oromo
OR	Oriya
or	Oriya
OS	Ossetian; Ossetic
os	Ossetian; Ossetic
PA	Panjabi; Punjabi
pa	Panjabi; Punjabi
PI	Pali
pi	Pali
PL	Polish
pl	Polish
PS	Pushto; Pashto
ps	Pushto; Pashto
PT	Portuguese
pt	Portuguese
QU	Quechua

Used Codes

qu	Quechua
RM	Romansh
rm	Romansh
RN	Rundi
rn	Rundi
RO	Romanian
ro	Romanian
RU	Russian
ru	Russian
RW	Kinyarwanda
rw	Kinyarwanda
SA	Sanskrit
sa	Sanskrit
SC	Sardinian
sc	Sardinian
SD	Sindhi
sd	Sindhi
SE	Northern Sami
se	Northern Sami
SG	Sango
sg	Sango
SI	Sinhala; Sinhalese
si	Sinhala; Sinhalese
SK	Slovak
sk	Slovak
SL	Slovenian
sl	Slovenian
SM	Samoaan
sm	Samoaan
SN	Shona
sn	Shona
SO	Somali
so	Somali

Used Codes

SQ	Albanian
sq	Albanian
SR	Serbian
sr	Serbian
SS	Swati
ss	Swati
ST	Sotho, Southern
st	Sotho, Southern
SU	Sundanese
su	Sundanese
SV	Swedish
sv	Swedish
SW	Swahili
sw	Swahili
TA	Tamil
ta	Tamil
TE	Telugu
te	Telugu
TG	Tajik
tg	Tajik
TH	Thai
th	Thai
TI	Tigrinya
ti	Tigrinya
TK	Turkmen
tk	Turkmen
TL	Tagalog
tl	Tagalog
TN	Tswana
tn	Tswana
TO	Tonga (Tonga Islands)
to	Tonga (Tonga Islands)
TR	Turkish

Used Codes

tr	Turkish
TS	Tsonga
ts	Tsonga
TT	Tatar
tt	Tatar
TW	Twi
tw	Twi
TY	Tahitian
ty	Tahitian
UG	Uighur; Uyghur
ug	Uighur; Uyghur
UK	Ukrainian
uk	Ukrainian
UR	Urdu
ur	Urdu
UZ	Uzbek
uz	Uzbek
VE	Venda
ve	Venda
VI	Vietnamese
vi	Vietnamese
VO	Volapük
vo	Volapük
WA	Walloon
wa	Walloon
WO	Wolof
wo	Wolof
XH	Xhosa
xh	Xhosa
YI	Yiddish
yi	Yiddish
YO	Yoruba
yo	Yoruba

Used Codes

ZA	Zhuang; Chuang
za	Zhuang; Chuang
ZH	Chinese
zh	Chinese
ZU	Zulu
zu	Zulu
4183	Special condition code Code specifying a special condition.
1	Item for national preference Item concerned is applicable to national preference calculation.
2	Item qualifying for payment discount Item concerned is applicable for settlement/payment discount calculation.
3	Item not qualifying for payment discount Item concerned is not applicable for settlement/payment discount calculation.
4	Urgent delivery of reserved goods Urgent delivery of goods for which a reservation was made.
5	Item not to be included in bonus calculation Item concerned is not applicable for bonus calculation.
6	Subject to bonus Item concerned is applicable for bonus calculation.
7	Subject to commission Item concerned is applicable for commission calculation.
8	Subject to discount Item concerned is applicable for discount calculation.
9	Freely available in EU Item should be available freely within the European Economic Community. GS1 Description: Item is freely available in the European Union.
10	Subject to settlement discount Item concerned is applicable for the overall settlement discount.
11	Price includes excise The stated price is inclusive of excise.
12	Price includes tax The stated price is inclusive of tax.
15	Not subject to discount Item concerned is not applicable for discount calculation.

Used Codes

18	Item subject to national export restrictions Item concerned requires export declaration.
96	Promotional advertising A media press communication informing about a promotion.
97	Promotional price Reduction in price for a specified period of time for promotional purposes.
98	Promotional shelf display Product in promotion is displayed in a special shelf or display.
99	Safety data sheet required to accompany goods when moved Material safety data sheet is required to accompany the goods when they are moved.
109	Sale or return Item concerned may be returned to supplier or otherwise disposed of if it remains unsold after a pre-determined period of time.
116	Subject to postponed discount The item concerned is applicable for postponed discount which will be refunded via a later credit.
119	Product genetically modified An indication that a product has been genetically modified during its production process.
123	Pharmacy sales only A special condition limiting the sale of a product to a pharmacy.
124	Sale requires medical prescription The sale of the product requires a medical prescription. GS1 Description: The identified product may only be sold in conjunction with a medical prescription.
125	New item, not yet available The item is new and not yet available.
126	New, available The item is new and available.
127	Obsolete The item is obsolete.
128	Prototype The item is a prototype and is not yet in normal production.
129	Non-standard product This item is not a standard product.
130	Discontinued The item is no longer available.

Used Codes

133	Gift supplied with purchase Product made available as a gift to a customer when purchasing an accompanying product.
134	Sale from promotional stock An indication that products sold came from promotional stock.
135	Sale from obsolete stock An indication that products sold came from obsolete stock.
136	Buying group conditions A code indicating that buying group conditions apply.
137	Cancel order unless complete delivery possible on requested date and or time Code indicating that the order is to be cancelled if complete delivery is not possible on the date and or time requested in the order.
140	Return of goods Special conditions related to the return of goods.
141	Subject to annual bonus Item concerned is applicable for annual bonus calculation.
142	Invoiced but not replenished A special condition indicating the fact that goods which have not yet been replenished have been invoiced.
143	Replenished but not invoiced A special condition indicating the fact that goods which have been replenished have not yet been invoiced.
144	Deliver full order A special condition indicating that delivery of the order will only be accepted in full.
147	Special handling requirements at point of receipt An indication that the product requires special handling at the point of receipt.
148	Supply direct delivery Goods to be supplied direct delivery to the delivery store and not through a distribution centre or a warehouse.
150	Mixed item pallet Goods to be supplied on mixed item pallet.
151	Items from the same dye lot The items should be supplied from the same dye lot.
152	Awaiting credit clearance Processing of the referenced document is delayed while credit clearance is obtained.
153	Return publication full copies Return the full copies of a publication.

Used Codes

154	Return publication headings only Return only the heading of a publication.
155	Destroy publication Destroy the publication by whatever means, but in such a way that it cannot be read afterwards.
157	Not subject to sale or return Product supplied not subject to sale or return.
158	Item to be sold in both domestic and export markets The item will be sold in both the domestic and export markets.
159	Item to be sold only in export markets The item will be sold only in export markets.
164	Shipment completes order There will be no further shipments for this order as it is considered complete.
165	Split shipment Subsequent shipment(s) will arrive for this order as it has been split over more than one shipment.
166	Include in continuous replenishment calculation An indication that a product or group of products are to be included in the continuous replenishment calculation.
167	Remove from continuous replenishment calculation An indication that a product or group of products are to be removed from the continuous replenishment calculation.
168	Standard pack shipment The shipment contains only standard packs.
169	Pick pack shipment The shipment contains only packages resulting from a pick and pack operation. GS1 Description: Where the hierarchy of the shipment resulting from a pick and pack operation has the article level sub-ordinate to the packaging level.
170	Goods for retail outlet shelf Goods to be placed on a retail outlet shelf.
171	Security stock The goods are required to maintain the security stock.
172	Production batch number allocated A batch number is allocated by the manufacturer to the item.
173	Production batch number allocated as required by law A batch number is allocated by the manufacturer to the item as required by law.

Used Codes

174	Product not genetically modified An indication that a product has not been genetically modified during its production process.
175	Suspended An item whose production or distribution has been suspended. EDIFACT
176	No re-ordering The item will not be re-ordered. EDIFACT
177	Product irradiated for preservation An indication that a product has had radioactive rays directed onto it to preserve it. EDIFACT
179	Product gluten-free An indication that a product does not contain any gluten.
180	Product contains gluten An indication that a product contains gluten.
181	Product lactose-free An indication that a product does not contain any lactose.
182	Product contains lactose An indication that a product contains lactose.
183	CH, compliant with Genetically Modified Food law An indication that a product complies with the Swiss law on genetically modified food.
184	CH, non-compliant with Genetically Modified Food law An indication that a product does not comply with the Swiss law on genetically modified food.
185	CH, compliant with General Food law An indication that a product complies with the Swiss general food law.
186	CH, non-compliant with General Food law An indication that a product does not comply with the Swiss general food law.
187	Store may not order The store is not allowed to order.
188	Distribution centre may not order Distribution centre is not allowed to order.
189	Net content declaration indicated A declaration of a trade item's net content is on the product label.
190	Net content declaration not indicated A declaration of a trade item's net content is not on the product label.

Used Codes

191	Not irradiated Radiation has not been applied.
192	Batch or lot number not allocated The trade item has no batch or lot number.
193	Unsold trade item not returnable A trade item that is not sold cannot be returned.
194	Ingredient irradiated Radiation has been applied to a trade item's ingredient.
195	Ingredients not irradiated Radiation has not been applied to any trade item's ingredient.
196	Raw material irradiated Radiation has been applied to a trade item's raw material.
197	Raw material not irradiated Radiation has not been applied to any trade item's raw material.
198	Re-orderable The item may be re-ordered.
199	Receipt advice, fully detailed Includes qualitative and/or quantitative details regarding everything received (all line items) whether or not there were exceptions between what was received and what was advised as being sent.
200	Receipt advice, only exceptions Includes only qualitative and/or quantitative exceptions between what was received and what was advised as being sent.
201	Ingredient is irradiated not applicable The indication that an ingredient of a trade item is irradiated is not applicable.
202	Raw material is irradiated not applicable The indication that raw material of a trade item is irradiated is not applicable.
203	Trade item is genetically modified not applicable The indication that a product has not been genetically modified is not applicable
204	Ingredient is irradiated not applicable The indication that a trade item is irradiated is not applicable.
205	Size dependent pricing An item price may be different depending of the size.
206	Size independent pricing An item price is independent of the size.
207	Only accepted products Includes only details regarding accepted products.

Used Codes

208	Financial compensation Special condition related to a financial compensation.
209	Wrong order Complete order credited due to a wrong order that was previously invoiced.
210	Quality defect Special condition due to quality defect of delivered trade items.
211	Wrong price Special condition related to a previously invoiced incorrect price.
53E	Await further instructions (GS1 Temporary Code) Wait for further instructions as to what to do with the publications. These instructions will either be given in electronic form or by other means such as letter, fax, e-mail.
55E	No action (GS1 Temporary Code) Code indicating the fact that no actions have taken place since the last message.
59E	No pallets (GS1 Temporary Code) Goods are to be supplied without pallets.
61E	Mono item pallet (GS1 Temporary Code) Goods to be supplied on mono item pallet.
69E	Product data publically available (GS1 Temporary Code) A code indicating the fact that the data associated with the current product may be made publically available on a product data base.
70E	Product data not publically available (GS1 Temporary Code) A code indicating the fact that the data associated with the current product may not be made publically available on a product data base.
73E	Delivery subject to final authorization (GS1 Temporary Code) Code indicating the fact that delivery of the order should not take place until final authorization has been received from the delivery party or buyer.
74E	Subject to special rules for hazardous materials (GS1 Temporary Code) A code to indicate that the product is subject to special hazardous materials rules.
75E	Not subject to special rules for hazardous materials (GS1 Temporary Code) A code to indicate that the product is not subject to special hazardous materials rules.
76E	Special conditions applicable to only this invoice (GS1 Temporary Code) This invoice is subject to some special conditions.
77E	Installation order conditions (GS1 Temporary Code) A code indicating order conditions related the installation for the first time, or complete restocking, of the entire range of a retail outlet.

Used Codes

79E	Discrepancies or adjustments (GS1 Temporary Code) Special conditions related to discrepancies or adjustments.
88E	Commodity (GS1 Temporary Code) Company's standard product.
90E	Temporarily out (GS1 Temporary Code) Item is temporarily not available.
91E	Manufacture out (GS1 Temporary Code) Item is out of production.
93E	Seasonally available only (GS1 Temporary Code) Product described is only available in specific seasons or time periods in a year, e.g. christmas decorations.
94E	Deletion, announcement only (GS1 Temporary Code) An announcement to say that the item is in the process of being deleted from the supplier's product range
95E	Temporary product (GS1 Temporary Code) A product which is only available for a temporary period of time.
96E	Product again available (GS1 Temporary Code) A product which was previously unavailable which is once again available.
ACD	Party has access to all non publically available data (GS1 Temporary Code) The identified party has access to all non publically available pricing and non-pricing data associated with the current product.
ACN	Party has access only to non publically available non-pricing data (GS1 Temporary Code) The identified party has access only to the non publically available non-pricing data associated with the current product.
ACP	Party has access only to non publically available pricing data (GS1 Temporary Code) The identified party has access only to the non publically available pricing data associated with the current product.
X1	No back orders when partial delivery (GS1 Temporary Code) Indication that no back orders are allowed when there is a partial delivery.
X10	Include article surveillance (GS1 Temporary Code) Product should contain article surveillance.
X18	Final consumer reservation (GS1 Temporary Code) Goods to be supplied with maximum urgency because final consumer has made reservation (in a retail outlet).
X19	Shelf replenishment merchandise (GS1 Temporary Code) Goods to be placed in a retail outlet shelf.

Used Codes

X2	Back orders accepted when partial delivery (GS1 Temporary Code) Indication that back orders are accepted when there is a partial delivery.
X20	Security stock merchandise (GS1 Temporary Code) Goods to maintain the security stock of a retail outlet.
X44	Item to be included in bonus calculation (GS1 Temporary Code) Item will be included when calculating agreed bonuses.
X5	End consumer promotional item (GS1 Temporary Code) Item is an end consumer promotional item.
X61	Is reload (GS1 Temporary Code) Value indicating the state of the Catalogue Item within the Request for Notification Process being currently on the Notification List.
X62	Is not reload (GS1 Temporary Code) Value indicating the state of the Catalogue Item within the Request for Notification Process being Initial Load.
X8	Provisional (GS1 Temporary Code) Item concerned is provisional.
X9	No empties (GS1 Temporary Code) No empty packaging to exchange, e.g. no empty bottles for ordered drinks.
4221	Discrepancy nature identification code Code specifying the identification used to define the nature of a discrepancy.
AA	Item discontinued by wholesaler The wholesaler no longer offers the ordered product.
AB	Item no longer produced The item ordered has been discontinued and is no longer in production.
AC	Over-shipped Code indicating that there was an excess quantity of goods in a shipment relative to the order.
AD	Item out of stock at manufacturer The item is out of stock at manufacturer.
AE	Delivered but not advised Shipment or goods have been delivered without any advance notification of delivery.
AF	Goods delivered damaged Part or all of the goods in a shipment were delivered damaged.
AG	Delivered too late Delivered but at a later date than the delivery date under the agreed conditions or stipulated in the order.

Used Codes

AH	<p>Next higher packaging quantity The ordered item has been, or is to be, packed to the next higher packaging quantity.</p> <p>GS1 Description: An indication from the buyer which allows the supplier to pack, if required, the ordered item to its next higher complete level of packaging.</p>
AS	<p>Available now - scheduled to ship (date) The material is available for shipment and is committed for shipment/delivery at a future date.</p> <p>GS1 Description: Back ordered product (product which has been ordered, was not delivered as scheduled but which the buyer still expects to receive at a later date) is now available and is scheduled for shipment on a specified date.</p>
BK	<p>Back ordered from previous order An order is being held as no material is available to fulfil the requirement.</p> <p>EDIFACT</p>
BP	<p>Shipment partial - back order to follow A portion of the previous order is being held as open, as enough material was not available to fulfil the requirement.</p> <p>GS1 Description: The shipment is incomplete, the missing quantities are to follow.</p>
CC	<p>Shipment complete The quantity dispatched fulfilled the order quantity.</p> <p>GS1 Description: The shipment is complete.</p>
CE	<p>Shipment includes extra items to meet price break The quantity dispatched exceeds the order quantity to accommodate a quantity of scale price model opportunity.</p> <p>GS1 Description: An additional quantity to the quantity ordered has been added for special discounts.</p>
CK	<p>Cancelled from previous order Amount deleted from the earlier schedule.</p> <p>EDIFACT</p>
CM	<p>Shipment complete with additional quantity The quantity dispatched exceeds the ordered quantity.</p> <p>GS1 Description: The shipment is complete and includes an additional quantity.</p>
CN	<p>Next carrier, PVE - (date) Self explanatory.</p> <p>GS1 Description: Item will be shipped on the next available or scheduled carrier.</p>

Used Codes

CP	<p>Shipment partial - considered complete, no backorder The quantity shipped is less than the amount authorized and there is no plan to ship the remaining amount.</p> <p>GS1 Description: Shipment does not fulfil the complete order but should be considered complete. Unshipped items are not considered to be on backorder.</p>
CS	<p>Shipment complete with substitution The quantity and product shipped, though not exactly matching the original order, is compliant with and fulfils the expectation.</p> <p>GS1 Description: Shipment considered complete. One or more items in the order have been substituted by other items.</p>
IC	<p>Item cancelled The material previously ordered is no longer needed.</p> <p>GS1 Description: Item has been cancelled from the order by the buyer or supplier.</p>
IS	<p>Item represents substitution from original order The quantity and product shipped is compliant with the expectation.</p> <p>GS1 Description: Item substitutes another item originally ordered.</p>
OS	<p>Item out of stock because of strike of force majeure Item is not available due to strike or an unforeseeable event.</p>
OW	<p>Item out of stock at wholesaler Item is not available at the distribution point.</p>
PO	<p>Purchase order inquiry - unshipped items only The response includes information concerning all of the articles that were not dispatched and included in the prior inquiry that had been requested by the contact initiator.</p> <p>EDIFACT</p>
PP	<p>Purchase order inquiry - specific items The response includes information concerning a unique sub-set of the total list of articles that the contract initiator had requested information on.</p> <p>EDIFACT</p>
PS	<p>In process - scheduled to ship (date) This amount is being manufactured in anticipation for a possible authorization for shipment.</p> <p>EDIFACT</p>
RA	<p>Item rationed Product is restricted because of limited availability.</p> <p>GS1 Description: Item has been rationed, ordered quantity exceeds rationed quantity.</p>

Used Codes

TW	Item temporarily discontinued by wholesaler Product is, for the time being, not available from the distribution point. GS1 Description: The item has been temporarily removed from the product range of the wholesaler.
US	Pack to closest complete logistic packaging quantity Pack to the closest complete logistic packaging quantity. GS1 Description: An indication from the buyer which allows the supplier to pack, if required, the ordered item to its closest complete level of packaging.
UT	Pack to next lower complete logistic quantity Pack to the next lower complete logistic packaging quantity. GS1 Description: An indication from the buyer which allows the supplier to pack, if required, the ordered item to the next lowest complete logistics packaging.
4277	Payment terms description identifier Identification of the terms of payment between the parties to a transaction (generic term). Notes: 1. Recommend use UN/ECE Recommendation No. 17 Payterms.
1	Draft(s) drawn on issuing bank Draft(s) must be drawn on the issuing bank.
2	Draft(s) drawn on advising bank Draft(s) must be drawn on the advising bank.
3	Draft(s) drawn on reimbursing bank Draft(s) must be drawn on the reimbursing bank.
4	Draft(s) drawn on applicant Draft(s) must be drawn on the applicant.
5	Draft(s) drawn on any other drawee Draft(s) must be drawn on any other drawee.
6	No drafts No drafts required.
ZZZ	Mutually defined (GS1 Temporary Code) A code identifying mutually defined payment terms.
4279	Payment terms type code qualifier Code qualifying the type of payment terms.
3	Fixed date Payments are due on the fixed date specified.

Used Codes

7	Extended Payment is extended beyond the normal due date.
4295	Change reason description code Code specifying the reason for a change.
AA	Member attribute change An attribute of a member of a group has changed.
AC	Member category change The member or benefits category has changed.
AJT	Adjustment (GS1 Temporary Code) Code indicating that an adjustment has taken place.
AQ	Alternate quantity and unit of measurement Change is due to an alternate quantity and unit of measurement. GS1 Description: Code indicating an alternate quantity and unit of measure than that was previously agreed.
AR	Article out of assortment for particular company Item normally part of a suppliers standard assortment but is unavailable for a specific buyer due to legal or commercial reasons.
ARP	Article to be published (GS1 Temporary Code) The article has to be published.
AS	Article out of assortment Article normally part of a standard assortment is unavailable.
AT	Item not ordered Code indicating the item or product was not ordered.
AU	No delivery due to outstanding payments Delivery of an item was stopped due to outstanding deliveries which have not yet been paid.
AUE	Article code unknown (GS1 Temporary Code) Item identification code (GTIN article number) is unknown. GS1 Note: Code marked for deletion. Use value BJ instead.
AV	Out of inventory Item is out of inventory.
AY	Sale location different Sold in a different sales location. GS1 Description: The reason for a different price is a different sale location and a different type of sale location, for example, a duty paid shop or a duty free shop.

Used Codes

BA	Damaged Goods CA change resulting from damaged goods. EDIFACT
BB	Transport means technical failure Transport means had a technical failure, e.g. transport means could not be unloaded or did not comply with hygienic requirements.
BC	Equipment technical failure Equipment had a technical failure, e.g. equipment was damaged or wrong.
BE	Goods technical failure Goods had a technical failure, e.g. instability, overhang, transportation lock or damage.
BF	Spoilage of goods A change resulting from the spoilage of goods.
BG	Grade difference out of tolerance level The change is due to a variation in the grade of the product outside the tolerance level allowed in an agreement.
BH	Batch number difference The batch number printed on the product received is different to the batch number specified in the despatch advice message.
BI	Expiry date difference The expiry date printed on the product received is different from the expiry date specified in the despatch advice message. GS1 Note: Replaces GS1 Temporary Code X40.
BJ	Item identification code unknown The item identification code is unknown. GS1 Note: Replaces GS1 Temporary Code AUE.
BK	Barcode not readable Barcode is not readable by a barcode scanning device. GS1 Note: Replaces GS1 Temporary Code BN_OLD.
BL	Item represents substitution from original order Code indicating the item or product is a substitute of the item or product originally ordered. GS1 Note: Replaces GS1 Temporary Code IS.
BM	Minimum/maximum product durability date unacceptable Code indicating that the minimum durability date (e.g. best before date) and/or maximum durability date (e.g. expiry date) of a product are not acceptable. GS1 Note: Replaces GS1 Temporary Code PE.
BN	Temperature outside agreed range The temperature is or has been outside the agreed range. GS1 Note: Replaces GS1 Temporary Code X32.

Used Codes

BN_OLD	<p>Bar code not readable (GS1 Temporary Code)</p> <p>Bar code is not readable for some reason (e.g. poor print quality) by a bar code scanning device.</p> <p>GS1 Note: Code marked for deletion. Use value BK instead.</p>
BO	<p>Delivered but not advised</p> <p>Shipment or goods have been delivered without any advance notification of delivery.</p> <p>GS1 Note: Replaces GS1 Temporary Code X33.</p>
BP	<p>Short shipped</p> <p>The quantity of goods received is smaller than advised.</p> <p>GS1 Note: Replaces GS1 Temporary Code X34.</p>
BR	<p>Item withdrawn</p> <p>The item has been withdrawn.</p> <p>GS1 Note: Replaces GS1 Temporary Code X35.</p>
BS	<p>SSCC difference</p> <p>The logistic unit is identified by another Serial Shipping Container Code (SSCC) than the one announced in the despatch advice.</p> <p>GS1 Note: Replaces GS1 Temporary Code X37.</p>
BT	<p>SSCC missing</p> <p>The logistic unit is missing its Serial Shipping Container code (SSCC).</p> <p>GS1 Note: Replaces GS1 Temporary Code X38.</p>
BU	<p>Best before date(s) difference</p> <p>The best before date(s) deviate(s) from those announced in the despatch advice.</p> <p>GS1 Note: Replaces GS1 Temporary Code X39.</p>
BV	<p>Weight difference</p> <p>More or less weight was received than announced in the despatch advice.</p> <p>GS1 Note: Replaces GS1 Temporary Code X41.</p>
BW	<p>Quantity difference</p> <p>More or less units were received than announced in the despatch advice.</p>
BX	<p>Delivered too late</p> <p>Delivered but at a later date than the delivery date under the agreed conditions or stipulated in the preceding message.</p> <p>GS1 Note: Replaces GS1 Temporary Code X43.</p>
IS	<p>Item represents substitution from original order (GS1 Temporary Code)</p> <p>Code indicating the item or product is a substitute of the item or product originally ordered.</p> <p>GS1 Note: Code marked for deletion. Use value BL instead.</p>
PC	<p>Pack difference</p> <p>Self-explanatory.</p> <p>GS1 Description: The packaging of the product has changed.</p>

Used Codes

PE	Minimum/maximum product durability date unacceptable (GS1 Temporary Code) Code indicating that the minimum durability date (e.g. best before date) or maximum durability date (e.g. expiry date) of a product are not acceptable. GS1 Note: Code marked for deletion. Use value BM instead.
PS	Product/services ID change The product/services identification has changed.
QT	Quantity price break The quantity price break has changed. GS1 Description: Additional quantity shipped to meet special discount conditions.
UM	Unit of measure difference The change is due to a difference in the unit of measure. GS1 Description: The unit of measure for the product shipped is different to the unit of measure for the product ordered.
WQ	Over shipped A shipped quantity greater than the ordered or invoiced quantity.
WR	Temporarily unavailable Product is temporarily unavailable.
WT	Excluded from the promotion activity Product is not included in the promotion activity.
WU	Committed purchase quantity exceeded The committed purchase quantity has been exceeded.
WV	Committed purchase quantity not ordered The committed purchase quantity has not been ordered.
X29	Government price charge (GS1 Temporary Code) Reason for price charge is due to government action.
X32	Receipt temperature outside agreed range (GS1 Temporary Code) The temperature at which the goods are received is outside the agreed range. GS1 Note: Code marked for deletion. Use value BN instead.
X33	Delivered but not advised (GS1 Temporary Code) Shipment or goods have been delivered without any advance notification of delivery. GS1 Note: Code marked for deletion. Use value BO instead.
X34	Missing (GS1 Temporary Code) The quantity of goods received is smaller than advised. GS1 Note: Code marked for deletion. Use value BP instead.
X35	Article withdrawn (GS1 Temporary Code) The article has been withdrawn GS1 Note: Code marked for deletion. Use value BR instead.

Used Codes

X36	Best before date out of chronological order (GS1 Temporary Code) Goods have a best before date which is out of chronological order.
X37	Wrong SSCC (GS1 Temporary Code) The logistic unit is identified by another SSCC than the one announced in the despatch advice. GS1 Note: Code marked for deletion. Use value BS instead.
X38	SSCC missing (GS1 Temporary Code) The logistic unit is missing its SSCC. GS1 Note: Code marked for deletion. Use value BT instead.
X39	Wrong best before date(s) (GS1 Temporary Code) The best before date(s) deviates from the one announced in the despatch advice. GS1 Note: Code marked for deletion. Use value BU instead.
X40	Wrong expiry date(s) (GS1 Temporary Code) The expiry date(s) deviates from the one announced in the despatch advice. GS1 Note: Code marked for deletion. Use value BI instead.
X41	Different weight (GS1 Temporary Code) More or less weight was received than expected with regard of what was announced in the despatch advice. GS1 Note: Code marked for deletion. Use value BV instead.
X42	Over-shipped (GS1 Temporary Code) An excess quantity of goods was received in a shipment with regard of what was expected in the despatch advice. GS1 Note: Code marked for deletion. Use value WQ instead.
X43	Delivered too late (GS1 Temporary Code) Delivered but at a later date than the delivery date under the agreed conditions or stipulated in the preceding message GS1 Note: Code marked for deletion. Use value BX instead.
X44	GS1 bar code label missing (GS1 Temporary Code) The GS1 bar code label is missing
4347	Product identifier code qualifier Code qualifying the product identifier.
1	Additional identification Information which specifies and qualifies product identifications.
3	Substituted by The given item number is the number of the product that substitutes another one.
5	Product identification The item number is for product identification.

Used Codes

4441	Free text value code Code specifying free form text.
78E	Proof Of Delivery (GS1 Permanent Code) The mentioned URL refers to a Proof of Delivery document. This Code value can be used if DE 4451 of the FTX segment is ZXL.
0	
1	
2	
3	
4	
5	
6	
7	
8	
9	
10	
11	
12	
13	
14	
15	Currently out of stock
16	
17	
18	
19	
20	
21	
22	
23	
24	
25	
26	
27	
28	

Used Codes

29

30

31

32

33

34

36

37

38

39

40

41

42

43

44

45

46

47

48

49

50

51

52

53

54

55

56

57

58

59

60

61

62

Used Codes

63

64

65

66

67

68

69

70

71

72

73

74

75

76

77

78

79

80

81

82

83

84

85

86

87

88

89

90

91

92

93

94

95

Used Codes

96	
97	
98	
99	
ACN	Consignment order, no
ACY	Consignment order, yes
AF	Box Number
AFL	Tax-free export delivery The invoice refers to a tax-free export delivery.
AWV	Declaration for external sector statistics
BA	The issuer of the document is the goods/services providing company.
BE	The receiver of the document is the goods/services providing company.
BF	Butter fat Restriction of use: The butter/the intermediate product is subject to article, of VO(EG) Nr. 2571/97
BI	Barcode information
BKM	Adjustment of inventory quantity
CO2	CO2KostAufG Mandatory information according to § 3 para. 1 CO2KostAufG. If the tenant supplies himself with combustible, he has a claim for reimbursement against the landlord in accordance with § 6 para. 2 and § 8 para.2 CO2KostAufG.
DESADV	DESADV (fix value)
DUN	Do not record dues (supply only if immediately available)
DUY	Record dues (backorder if not immediately available)
EA	Lable type
EEV	The ownership is ours until full payment for goods.
FSN	Order not forwarded to publisher
FSY	Order forwarded to publisher
HA	Handling information
IGD	Intra-community triangular business
IGL	Tax free EU delivery Delivery within the EU comunity
INTRASTAT	Message to the Federal Statistical Office used to balance the actual merchandise traffic.
KA	Combined article (GS1_DE Code) Note on use of the simplification rule in case of combined articles.

Used Codes

KOR	Correction document
LES	The invoice contains items that are subject to the reverse charge procedure. In these cases, the beneficiary owes the VAT.
NACH-ORDER	Seasonal Repeat Order for continuous ordering and deliver
NE	Customer name
NOI	This document is no invoice or credit note by means of VAT law. The indicated VAT does not allow the deduction of input tax.
NOS-ORDER	The document relates to NOS (Never out of stock) articles, that are continuously reordered and replenished. (CRP)
OWN	Do not forward order to publisher
OWY	Forward order to publisher
PKN	Backorder until agreed order volume is reached, no
PKY	Backorder until agreed order volume is reached, yes
PT	Price text
PWN	Batch bonus, no
PWY	Batch bonus, yes
RN	Number of storage rack
RWN	Remittance, no
RWY	Remittance, yes
SE00	The price indicated is exempted from tax.
SE07	The reduced tax rate of 7% is valid for the price indicated.
SE19	The tax rate of 19% is valid for the price indicated.
ST1	Fee reduction applies, due to discount and bonus agreements.
ST2	Fee reduction applies, due to our current business terms.
ST3	Discount or bonus agreements apply.
TUN	Do not supply replacement article
TUY	Automatic supply of replacement article
UHR	Copyright fee
VEV	The ownership is ours until full payment of outstanding money. This is also true for resale or further processing.
VOR-ORDER	Seasonal Start Order for installation order conditions
WBM	Goods movement quantity
WEV	The ownership is ours until full payment of outstanding money.
ZRN	Central settlement, no
ZRY	Central settlement, yes

Used Codes

4451	Text subject code qualifier Code qualifying the subject of the text.
DEL	Delivery information Information about delivery.
PUR	Purchasing information Note contains purchasing information.
4453	Free text function code Code specifying the function of free text.
1	Text for subsequent use The occurrence of this text does not affect message processing.
5025	Monetary amount type code qualifier Code qualifying the type of monetary amount.
25	Charge/allowance basis The amount specified is the basis for calculation of charges/allowance.
79	Total line items amount The sum of all the line item amounts.
5125	Price code qualifier Code qualifying a price. Notes: 1. The code set from data element 5387 may also be used as agreed among trading partners.
1E	Calculation net - including taxes (GS1 Temporary Code) The price stated is the net price including all allowances and charges, and including taxes. Allowances and charges may be stated for information purposes only.
AAA	Calculation net The price stated is the net price including allowances/ charges. Allowances/ charges may be stated for information only. GS1 Description: The price stated is the net price including allowances/ charges and excluding taxes. Allowances/charges may be stated for information only.
AAB	Calculation gross The price stated is the gross price to which allowances/charges, if valid, must be applied. GS1 Description: The price stated is the gross price excluding all allowances, charges and taxes. Allowances and charges must be stated and used for net calculation purposes.

Used Codes

AAE	Information price, excluding allowances or charges, including taxes The price stated is for information purposes only and excludes all allowances and charges. Taxes however are included in the price.
AAF	Information price, excluding allowances or charges and taxes The price stated is for information purposes only and excludes all allowances, charges and taxes.
AAH	Subject to escalation and price adjustment Subject to increase or development by successive stages and price adjustment.
AAQ	Firm price Price which will remain unchanged for a given time period.
ABL	Base price The base price of a product or service.
ABM	Base price difference The difference in price against a base price.
CAL	Calculation price The price stated is the price for the calculation of the line item amount.
INF	Information The price is provided for information.
5153	Duty or tax or fee type name code Code specifying a type of duty, tax or fee.
VAT	Value added tax A tax on domestic or imported goods applied to the value added at each stage in the production/distribution cycle.
5245	Percentage type code qualifier Code qualifying the type of percentage.
3	Allowance or charge [5424] Allowance or charge expressed as a percentage.
5273	Duty or tax or fee rate basis code Code specifying the basis for a duty or tax or fee rate.
1	Value (5316) To specify that the applicable rate of duty, tax or fee is based on the Customs value (CCC).
2	Weight (6150) To specify that the applicable rate of duty, tax or fee is based on the weight of the item (CCC).

Used Codes

3	Quantity (6060) To specify that the applicable rate of duty, tax or fee is based on the quantity of the item (CCC).
5283	Duty or tax or fee function code qualifier Code qualifying the function of a duty or tax or fee.
7	Tax Contribution levied by an authority.
5305	Duty or tax or fee category code Code specifying a duty or tax or fee category.
A	Mixed tax rate Code specifying that the rate is based on mixed tax. GS1 Description: Transaction includes item taxed at different rates.
AA	Lower Rate Tax rate is lower than standard rate.
AC	Value Added Tax (VAT) not now due for payment A code to indicate that the Value Added Tax (VAT) amount which is due on the current invoice is to be paid on receipt of a separate VAT payment request. GS1 Description: The value added tax is not due for payment now.
AE	VAT Reverse Charge Code specifying that the standard VAT rate is levied from the invoicee. GS1 Description: Code specifying that the rate is based upon the reverse charge VAT treatment which is always standard rate tax.
C	Duty paid by supplier Duty associated with shipment of goods is paid by the supplier; customer receives goods with duty paid.
D	Value Added Tax (VAT) margin scheme - travel agents Indication that the VAT margin scheme for travel agents is applied.
E	Exempt from tax Code specifying that taxes are not applicable. GS1 Description: All items in the transaction or a specific line item are exempt from tax.
F	Value Added Tax (VAT) margin scheme - second-hand goods Margin scheme for second-hand goods.
G	Free export item, tax not charged Indication that the VAT margin scheme for second-hand goods is applied.

Used Codes

H	Higher rate Code specifying a higher rate of duty or tax or fee. GS1 Description: All items in the transaction or a specific line item are taxed at the higher rate of tax.
I	Value Added Tax (VAT) margin scheme - works of art Indication that the VAT margin scheme for works of art is applied.
J	Value Added Tax (VAT) margin scheme - collector's items and antiques Indication that the VAT margin scheme for collector's items and antiques is applied.
O	Services outside scope of tax Code specifying that taxes are not applicable to the services.
S	Standard rate Code specifying the standard rate. GS1 Description: All items in the transaction or a specific line item are taxed at the standard rate of tax.
Z	Zero rated goods Code specifying that the goods are at a zero rate. GS1 Description: All items in the transaction or a specific line item are zero tax rated.

5375	Price type code Code specifying the type of price.
CA	Catalogue Code specifying the catalogue price. GS1 Description: The price detailed is the price detailed in the currently referenced catalogue.

5387	Price specification code Code identifying pricing specification.
LIU	List price (GS1 Temporary Code) Regular list price (no promotions or special discounts applied).
RTP	Retail price Price per unit of quantity of a product to be used for retail.
SRP	Suggested retail price Price per unit of quantity of a product suggested for retail.

5463	Allowance or charge code qualifier Code qualifying an allowance or charge.
-------------	---

Used Codes

A	Allowance Code specifying an allowance. GS1 Description: Deduction in the form of a rate, amount, percentage, or quantity to the price or amount charged for a product.
C	Charge Code specifying a charge. GS1 Description: Addition in the form of a rate, amount, percentage, or quantity to the price or amount charged for a product.
6063	Quantity type code qualifier Code qualifying the type of quantity.
12	Despatch quantity Quantity despatched by the seller.
21	Ordered quantity The quantity which has been ordered.
83	Backorder quantity The quantity of goods that is on back-order. GS1 Description: Quantity of a product for backorder purposes.
192	Free goods quantity Quantity of goods which are free of charge.
6311	Measurement purpose code qualifier Code qualifying the purpose of the measurement.
AAI	Item weight Weight at line item level.
PD	Physical dimensions (product ordered) Specified measurement dimensions refer to physical dimensions of a product, material or package. GS1 Description: The restriction 'product ordered' can be ignored.
6313	Measured attribute code Code specifying the attribute measured.
A	Consolidated weight The measured consolidated weight.
AAA	Unit net weight GS1 Description: Weight (mass) of the goods without any packing.

Used Codes

AAB	Unit gross weight [6292] Weight (mass) of goods including packing but excluding the carrier's equipment.
AAC	Total net weight Total weight of goods excluding packaging. GS1 Description: "Total" in this code means the sum of the net weight of all items.
AAD	Total gross weight [6292] Weight (mass) of goods including packing but excluding the carrier's equipment. GS1 Description: "Total" in this code means the sum of the gross weight of all items.
AAJ	Number of units per pallet The number of units contained on a pallet. GS1 Description: An indication of the number of units on a loaded pallet. The value associated with this code is calculated by multiplying the number of units per layer by the number of layers on a pallet.
AAK	Fat content An indication of the fat content of a product.
AAL	Net weight GS1 Description: Weight (mass) of goods excluding packaging. GS1 usage note: The field of implementation of this code is the area of transport and related activities such as the preparation of goods into consignments for shipping.
AAO	Humidity Self-explanatory.
AAP	Voltage Self-explanatory.
AAQ	Power consumption Value of energy consumption.
AAR	Heat dissipation Self-explanatory.
AAU	Operative temperature Temperature identified system or process works according to specifications.
AAW	Gross volume The observed volume unadjusted for factors such as temperature or gravity. GS1 Description: The usage of this code relates to the contents, e.g. gases or liquids that expand/contract under given circumstances.

Used Codes

AAX	<p>Net volume</p> <p>The observed volume after adjustment for factors such as temperature or gravity.</p> <p>GS1 Description: The usage of this code relates to the contents, e.g. gases or liquids that expand/contract under given circumstances.</p>
AAY	<p>Water content</p> <p>Water content in product.</p>
ABF	<p>Item width when unrolled</p> <p>The width of an item when unrolled.</p>
ABG	<p>Item length when unrolled</p> <p>The length of an item when unrolled.</p>
ABH	<p>Item area when unrolled</p> <p>The area occupied by an item when unrolled.</p>
ABI	<p>Original wort</p> <p>Measure of the malt and hops content of beer, before fermentation has taken place.</p>
ABJ	<p>Volume</p> <p>The amount of air space taken up by the entity identified in the 6311 qualifier.</p> <p>GS1 Description: The usage of this code relates to the cube of air that the package takes up.</p>
ABK	<p>Angle</p> <p>The angle of an object.</p> <p>EDIFACT</p>
ABL	<p>Peg hole horizontal distance from package leftmost edge</p> <p>Horizontal distance from the left most edge of the package to the center of the hole into which the peg is inserted.</p> <p>EDIFACT</p>
ABM	<p>Peg hole vertical distance from top</p> <p>Vertical distance from the top of the package to the top of the hole into which the peg is inserted.</p> <p>EDIFACT</p>
ABO	<p>Product strength, chemical</p> <p>The amount of the single active chemical ingredient within a product.</p> <p>EDIFACT</p>
ABP	<p>Product strength basis, chemical</p> <p>Amount of product used as the basis for the specification of the chemical product strength.</p> <p>EDIFACT</p>
ABQ	<p>Percentage of alcohol (by volume)</p> <p>The percentage of alcohol contained in a liquid.</p>

Used Codes

ACG	Chargeable weight The weight on which charges are based.
ACN	Estimated gross weight Estimated weight (mass) of goods, including packing and excluding carrier's. GS1 Description: Estimated gross weight (mass) of goods, including packing and excluding carrier's equipment.
ACP	Estimated volume Estimated size or measure of anything in three dimensions. GS1 Description: The usage of this code relates to the cube of air that the package takes up.
ACV	Loading meters The length in a vehicle, whereby the complete width and height over that length is needed for the goods.
ADJ	Surface (GS1 Temporary Code) A measurement in relation a surface.
ADX	Transport container actual filling weight Actual filling weight of a transport container.
ADY	Transport container maximum capacity Maximum capacity of a transport container.
ADZ	Declared net weight The declared net weight of a product or products used for invoicing, customs or transport purposes. GS1 Description: The field of implementation of this code is the area of transport and/or customs.
AEA	Loading height Maximum height of products or packages loaded onto a given transportation device or equipment such as a pallet.
AEB	Stacking height Maximum height up to which the same product or package may be placed one upon the other for storage purposes.
AEI	Drained weight The weight of a product when all liquids used in the packaging of the product have been removed.
AEL	Area Extent or measure of a surface.
AEV	Acidity of juice Acid measurement of juice. GS1 Description: Acid number of juice of fruit measured with pH = 8.2.

Used Codes

AEW	Penetrometry Measurement of force required to drive a standard penetrating stamp.
AEX	Durofel Measurement of the elastic force using a standard penetrating stamp. GS1 Description: Measure of the elastic force of the pulp of a fruit. This is measured with a penetrating stamp and expressed as a percentage.
AEY	Juice weight per 100 grams Measurement of weight of juice, based on 100 grams of the entire weight. GS1 Description: Weight of juice, based on 100 grams of the entire fruit, expressed as a percentage.
AEZ	Fruit skin colour Measurement of the colouring of the epidermis of a fruit. GS1 Description: Colouring of the epidermis of a fruit measured with comparators. It indicates the maturity of the fruit or its commercial quality.
AFB	Durofel D10 Measure of the elastic force of the pulp of a fruit. It is measured with a penetrating stamp with diameter 10. GS1 Description: Measure of the elastic force of the pulp of a fruit. It is measured with a penetrating stamp with diameter 10. This measure is expressed as a percentage.
AFC	Durofel D25 Measure of the elastic force of the pulp of a fruit. It is measured with a penetrating stamp with diameter 25. GS1 Description: Measure of the elastic force of the pulp of a fruit. It is measured with a penetrating stamp with diameter 25. This measure is expressed as a percentage.
AFD	Durofel D50 Measure of the elastic force of the pulp of a fruit. It is measured with a penetrating stamp with diameter 50. GS1 Description: Measure of the elastic force of the pulp of a fruit. It is measured with a penetrating stamp with diameter 50. This measure is expressed as a percentage.
AFE	Maximum stacking weight The maximum weight which may be stacked upon a product or package without the product or packaging being crushed.
AFF	Gross measure cube The total cubic space occupied by an item, taking into account any protruding components, arrived at by multiplying the maximum length, width and height.

Used Codes

AFG	Percentage fat content in dry matter The percentage of fat content in dry matter.
AFH	Saccharometric content Measurement of the sugar content of a solution. EDIFACT
AFI	Hydrate content of an alcoholic product after bottling The hydrate content which occurs in an alcoholic product after bottling.
AFJ	Anhydrous content The non-water content. GS1 Description: Anhydrous content of an alcoholic product.
AFT	Colour depth The number of distinct colours represented, e.g. in an image or in a display.
AFU	Colour depth, maximum The maximum number of distinct colours that can be represented, e.g. in an image or in a display.
AFV	Image resolution The level of detail of an image.
AFW	Device resolution, maximum The maximum level of detail produced by a device.
AFX	Acoustic absorption coefficient The portion of sound energy a surface absorbs, measured at different frequencies.
BNU	Peg hole number Used to identify the peg hole if more than one hole is present in the product or packaging.
BNV	Number of inner packs Indicates the number of non coded physical groupings (inner packs) of next lower level trade items within the current trade item level.
BNW	Number of next level trade items within inner pack The number of next lower level trade items contained within the physical non-coded grouping (inner pack).
BNX	Number of trade items per pallet layer The number of trade items contained on a single layer of a pallet.
BNY	Packed items layer Height The height of a single layer of packed items.
BNZ	Packing material weight, skin tight covering The weight measurement of the packing material used for skin tight covering (e.g. when packaging prepared meats, poultry, cheese, and other food products).

Used Codes

BRB	Components labelled for recycling percentage Percentage of trade item components that clearly label how to facilitate product disassembly and recycling.
BRC	Renewable plastic components percentage, by net weight The percentage of the plastic components only made from rapidly renewable plant-based material by net weight of product.
BRD	Clamp pressure, required The pressure that should be applied by a clamp.
BUP	Number of base units per pallet (GS1 Temporary Code) The number of base units contained in a pallet.
CF1	Colony forming Unit (GS1 Temporary Code) Micro-organism colonies that are to be counted under determined conditions.
CT	Contents of package In combination with the other data elements of the actual segment this code indicates the measured content of a package.
DBX	Degree BRIX (GS1 Temporary Code) The rate of sugar.
DI	Diameter Diameter of an article.
DLL	Diluted liquid (GS1 Temporary Code) The volume of liquid which results after a dilution agent has been added, e.g. undiluted orange juice of 200ml, after dilution with water the volume of diluted liquid equals 1 litre.
DN	Density The measured density.
DP	Depth The measured depth.
ENE	Energy efficiency (GS1 Temporary Code) A measurement of the energy efficiency of an article.
G	Gross weight [6292] Weight (mass) of goods including packing but excluding the carrier's equipment. GS1 Description: The field of implementation of this code is the area of transport and related activities such as the preparation of goods into consignments for shipping.
HT	Height dimension Numeric value of height.
HYE	Hydrate content (GS1 Temporary Code) Hydrate content of an alcoholic product.

Used Codes

ID	<p>Inside diameter The measured inside diameter.</p> <p>GS1 Description: A measurement of the inside diameter of a roll, tube, pipe, or circle.</p>
LAY	<p>Number of layers (GS1 Temporary Code) Number of layers of a product or products within a package, container, pallet, etc.</p> <p>GS1 Description: Number of layers of a product or products within a package, container, pallet, etc.</p>
LN	<p>Length dimension (6168) Length of pieces or packages stated for transport purposes.</p>
MDM	<p>Maximum demand (GS1 Temporary Code) The highest demand recorded during the period of recording of usage of the supply.</p>
NPL	<p>Number of layers per pallet (GS1 Temporary Code) The number of layers per pallet.</p>
NPP	<p>Number of pallet places (GS1 Temporary Code) The number of pallet places needed to store or transport pallets (can be stacked).</p>
OD	<p>Outside diameter The measured outside diameter.</p> <p>GS1 Description: A measurement of the outside diameter of a roll, tube, pipe, or circle.</p>
PMC	<p>Package net measurement cube (GS1 Temporary Code) An indication of the net cubed measurement of a package.</p>
PWF	<p>Power factor (GS1 Temporary Code) The ration of the power dissipated (active power in kW) to the total power (which is the product of the input volts times amps given in kVa). When equipment which uses reactive power is being operated the power factor will be less than one.</p>
RA	<p>Relative humidity The measured relative humidity.</p>
RJ	<p>Rockwell C Hardness in the Rockwell C scale.</p>
SF	<p>Stacking factor excluding bottom item (GS1 Temporary Code) Maximum number of items stackable upon each other, excluding the bottom item.</p>
SPG	<p>Specific gravity (GS1 Temporary Code) The measured specific gravity.</p>

Used Codes

SSZ	Step size (GS1 Temporary Code) An indication of measurements in which options contained within a Customer Specific Article are available, e.g. 10 metre planks of wood may be sold in step sizes of 2 metres.
T	Tare weight Weight excluding goods and loose accessories.
TC	Temperature A measurement in relation to temperature.
TH	Thickness The measured thickness.
TN	Time period Measurement of a specific length of time.
UCO	Units per package (GS1 Temporary Code) The number of identified units per package.
ULY	Number of units per layer (GS1 Temporary Code) Number of units of a product or package within one layer of a package, container, pallet, etc.
WD	Width dimension Numeric value of width.
WRM	Weight per running metre (GS1 Temporary Code) A code used to indicate the weight per running metre of floor coverings over floor area.
WSM	Weight per square metre (GS1 Temporary Code) A code used to indicate the weight per square metre of floor coverings over floor area.
X01	Acidity of meat (1 hour after slaughtering) The meat's acid quality or condition expressed as a pH value measured 1 hour after slaughtering.
X02	Acidity of meat (12 hours after slaughtering) The meat's acid quality or condition expressed as a pH value measured 12 hours after slaughtering.
X03	Acidity of meat (24 hours after slaughtering) The meat's acid quality or condition expressed as a pH value measured 24 hours after slaughtering.
X04	Acidity of meat (36 hour(s) after slaughtering) The meat's acid quality or condition expressed as a pH value measured 36 hours after slaughtering.
X05	Acidity of meat (48 hour(s) after slaughtering) The meat's acid quality or condition expressed as a pH value measured 48 hours after slaughtering.

Used Codes

X13	Acidity of meat (GS1 Temporary Code) The meat's acid quality or condition expressed as a pH value.
X16	Slaughtering weight (GS1 Temporary Code) Warm weight after slaughter
X17	Stacking factor including bottom item (GS1 Temporary Code) Maximum number of items stackable upon each other, including the bottom item.
X1E	Number of units in the width of a layer (GS1 Temporary Code) Number of units of a product or package which make up the width of a layer in a package, container, pallet, etc.
X2E	Number of units in the depth of a layer (GS1 Temporary Code) Number of units of a product or package which make up the depth of a layer in a package, container, pallet, etc.
X6E	Nestable percentage (GS1 Temporary Code) Extent expressed as a percentage to which an item can be nested within an identical item.
X7E	Gross weight including carrier's equipment (GS1 Temporary Code) Weight (mass) of goods including packaging and the carrier's equipment. In this context 'carrier's equipment' means any material resources necessary to facilitate the transport and handling of the goods without having the ability to move by its own propulsion, e.g. pallet, container, etc. GS1 usage Note The field of implementation of this code is the area of transport and related activities such as the preparation of goods into consignments for shipping.
ZWA	Waste content The measured waste content.
6343	Currency type code qualifier Code qualifying the type of currency.
9	Order currency The name or symbol of the monetary unit used in an order.
10	Pricing currency The name or symbol of the monetary unit used for pricing purposes.
6345	Currency identification code Code specifying a monetary unit.
	Notes: 1. Use ISO 4217 three alpha code.
AED	Dirham
AFN	Afghani

Used Codes

ALL	Lek
AMD	Dram
ANG	Netherlands Antillian Guilder
AOA	Kwanza
ARS	Argentine Peso
AUD	Australian Dollar
AWG	Aruban Florin
AZN	Azerbaijan Manat
BAM	Convertible Mark
BBD	Barbados Dollar
BDT	Taka
BGN	Bulgarian Lev
BHD	Bahraini Dinar
BIF	Burundi Franc
BMD	Bermudian Dollar (customarily: Bermuda Dollar)
BND	Brunei Dollar
BOB	Boliviano
BOV	Mvdol
BRL	Brazilian Real
BSD	Bahamian Dollar
BTN	Ngultrum
BWP	Pula
BYN	Belarussian Ruble
BZD	Belize Dollar
CAD	Canadian Dollar
CDF	Franc Congolais
CHE	WIR Euro
CHF	Swiss Franc
CHW	WIR Franc
CLF	Unidad de Fomento
CLP	Chilean Peso
CNY	Yuan Renminbi
COP	Colombian Peso

Used Codes

COU	Unidad de Valor Real
CRC	Costa Rican Colon
CUC	Peso Convertible
CUP	Cuban Peso
CVE	Cabo Verde Escudo
CZK	Czech Koruna
DJF	Djibouti Franc
DKK	Danish Krone
DOP	Dominican Peso
DZD	Algerian Dinar
EGP	Egyptian Pound
ERN	Nakfa
ETB	Ethopian Birr
EUR	Euro
FJD	Fiji Dollar
FKP	Falkland Islands Pound
GBP	Pound Sterling
GEL	Lari
GHS	Ghana Cedi
GIP	Gibraltar Pound
GMD	Dalasi
GNF	Guinean Franc
GTQ	Quetzal
GYD	Guyana Dollar
HKD	Honk Kong Dollar
HNL	Lempira
HRK	Kuna
HTG	Gourde
HUF	Forint
IDR	Rupiah
ILS	New Israeli Sheqel
INR	Indian Rupee
IQD	Iraqi Dinar

Used Codes

IRR	Iranian Rial
ISK	Iceland Krona
JMD	Jamaican Dollar
JOD	Jordanian Dinar
JPY	Yen
KES	Kenyan Shilling
KGS	Som
KHR	Riel
KMF	Comorian Franc
KPW	North Korean Won
KRW	Won
KWD	Kuwaiti Dinar
KYD	Cayman Islands Dollar
KZT	Tenge
LAK	Lao Kip
LBP	Lebanese Pound
LKR	Sri Lanka Rupee
LRD	Liberian Dollar
LSL	Loti
LYD	Libyan Dinar
MAD	Morrocan Dirham
MDL	Moldovan Leu
MGA	Ariary
MKD	Denar
MMK	Kyat
MNT	Tugrik
MOP	Pataca
MRU	Ouguiya
MUR	Mauritius Rupee
MVR	Rufiyaa
MWK	Malawi Kwacha
MXN	Mexican Peso
MXV	Mexican Unidad de Inversion (UDI)

Used Codes

MYR	Malaysian Ringgit
MZN	Mozambique Metical
NAD	Namibia Dollar
NGN	Naira
NIO	Cordoba Oro
NOK	Norwegian Krone
NPR	Nepalese Rupee
NZD	New Zealand Dollar
OMR	Rial Omani
PAB	Balboa
PEN	Sol
PGK	Kina
PHP	Philippine Piso
PKR	Pakistan Rupee
PLN	Zloty
PYG	Guarani
QAR	Qatari Rial
RON	Romanian Leu This currency code is effective from 1 July 2005
RSD	Serbian Dinar
RUB	Russian Ruble
RWF	Rwanda Franc
SAR	Saudi Riyal
SBD	Solomon Islands Dollar
SCR	Seychelles Rupee
SDG	Sudanese Pound
SEK	Swedish Krona
SGD	Singapore Dollar
SHP	St. Helena Pound
SLL	Leone
SOS	Somali Shilling
SRD	Suriname Dollar
SSP	South Sudanese Pound

Used Codes

STN	Dobra
SVC	El Salvador Colon
SYP	Syrian Pound
SZL	Lilangeni
THB	Baht
TJS	Somoni
TMT	Turkmenistan New Manat
TND	Tunisian Dinar
TOP	Pa'anga
TRY	Turkish Lira
TTD	Trinidad and Tobago Dollar
TWD	New Taiwan Dollar
TZS	Tanzanian Shilling
UAH	Hryvnia
UGX	Uganda Shilling
USD	US Dollar
USN	US Dollar (Next day)
UYI	Uruguayo Peso en Unidades
UYU	Peso Uruguayo
UYW	Unidad Previsional
UZS	Uzbekistan Sum
VES	Bolívar Soberano
VND	Dong
VUV	Vatu
WST	Tala
XAF	CFA Franc
XAG	Silver
XAU	Gold
XBA	Bond Markets Units European Composite Unit (EURCO)
XBB	European Monetary Unit (E.M.U.-6)
XBC	European Unit of Account 9 (E.U.A.-9)
XBD	European Unit of Account 17 (E.U.A.-17)
XCD	East Carribean Dollar

Used Codes

XDR	SDR
XOF	CFA Franc
XPD	Palladium
XPF	CFP Franc
XPT	Platinum
XSU	Sucre
XTS	Codes specifically reserved for testing purposes
XUA	ADB Unit of Account
XXX	The codes assigned for transactions where no currency is involved
YER	Yemeni Rial
ZAR	Rand
ZMW	Zambian Kwacha
ZWL	Zimbabwe Dollar (effective 1 February 2009)

6347

Currency usage code qualifier
Code qualifying the usage of a currency.

1	Charge payment currency The currency in which charges are to be paid.
2	Reference currency The currency applicable to amounts stated. It may have to be converted.
3	Target currency The currency which should be used to the target destination of the transaction.

6411

Measurement unit code
Code specifying the unit of measurement.

Notes:

| 1. Recommend use UN/ECE Recommendation 20, Common code.

001	Barrel (205 litres, 45 gallons) (GS1 Temporary Code) A unit of liquids equivalent to 205 litres or 45 gallons.
23	gram per cubic centimetre GS1 Description: g/cm ³ as a unit of measure for the density of gas. This is necessary for dangerous substance articles for determination of the quantities that can be stored together on the shelf.
25	gram per square centimetre GS1 Description: A measure of weight in terms of gram per square centimetre.

Used Codes

28	kilogram per square metre GS1 Description: Unit of measure expressed in kilogram per square metre.
37	ounce per square foot
59	part per million
64	Pound per square inch, gauge A unit of measure expressed in pound per square inch
2N	decibel
2X	metre per minute GS1 Description: A measure of speed in terms of metres per minute.
4K	milliampere
4L	megabyte GS1 Description: A unit of computer memory equal to 1.048.576 (i.e. 2 power 20) bytes.
4O	microfarad GS1 Description: One millionth of a farad. A farad is the capacitance of a capacitor between the plates of which a potential of 1 volt is created by a charge of 1 Coulomb.
4P	newton per metre
A25	cheval vapeur
A86	gigahertz GS1 Description: Hertz multiplied by 10 ⁹ .
A99	Bit A unit of information equal to one binary digit.
ACR	acre GS1 Description: Acre (4840 yd ²)
AD	byte GS1 Description: A unit of information stored in a computer, equal to eight bits.
AMH	ampere hour GS1 Description: Ampere-hour (3,6kC)
AMP	ampere
AMT	amount
ANN	year GS1 Description: The expression of a year as a measure unit.

Used Codes

APZ	Troy ounce or apothecary ounce EDIFACT
ASM	alcoholic strength by mass GS1 Description: Alcoholic strength expressed by mass.
ASU	alcoholic strength by volume GS1 Description: Alcoholic strength expressed by volume.
AV	capsule GS1 Description: Encapsuled dosage form for pharmaceuticals.
B13	Joule per square metre A unit of measure of heat energy expressed in joule per square metre.
B17	Credit A unit of count defining the number of entries made to the credit side of an account.
BAR	bar GS1 Description: A unit of measure equal to 106 dines per square centimeter.
BTU	British thermal unit GS1 Description: British thermal unit (1,055 kilojoules)
C0	call GS1 Description: Unit of measure for telephone calls. Code value is C0 (C Zero).
C60	ohm centimetre GS1 Description: Unit of measure expressed in Ohm centimetre.
C79	Kilovolt Ampere Hour A unit of accumulated energy of 1000 volt amperes over a period of one hour. EDIFACT
CDL	candela GS1 Description: Unit of measure of light intensity.
CEL	degree celsius
CF2	Colony forming unit per gram (GS1 Temporary Code) Colony forming units per gram is a unit of measure for micro-organisms, such as bacteria, in a food item. Micro-organisms form colonies that are be counted under determined conditions
CLT	centilitre GS1 Description: A unit of volume equal to one hundredth of a liter.
CMK	square centimetre

Used Codes

CMQ	cubic centimetre GS1 Description: A system of units for the measurement of volume based on the cubic centimetre.
CMT	centimetre
D19	Square metre kelvin per watt Unit of measure of thermal insulance expressed in square metre kelvin per watt.
D21	square metre per kilogram GS1 Description: Unit of measure expressed in square metre per kilogram.
D32	Terawatt hour A unit of measure expressed in terawatt hour
D5	Kilogram per square centimetre A unit of measure expressed in kilogram per square centimetre
D55	Watt per square metre kelvin Unit of measure of thermal conductance expressed in watt per square metre kelvin.
D68	Number of Words A unit of count defining the number of words. EDIFACT
DAY	day GS1 Description: The expression of a day as a measure unit.
DD	degree GS1 Description: Unit of measure of temperature.
DMQ	cubic decimetre GS1 Description: Unit of measure expressed in cubic decimetre.
DMT	decimetre
DRG	Dragée (GS1 Temporary Code) Number of dragées (coated tablets) contained in the item's package as a measurement unit.
DZN	dozen GS1 Description: A unit of measure of 12 or group of 12.
E09	Milliampere hour A unit of power load delivered at the rate of one thousandth of an ampere over a period of one hour. EDIFACT

Used Codes

E10	Degree day A unit of measure used in meteorology and engineering to measure the demand for heating or cooling over a given period of days. EDIFACT
E11	Gigacalorie A unit of heat energy equal to one thousand million calories. EDIFACT
E27	Dose A unit of count defining the number of doses (dose: a definite quantity of a medicine or drug). EDIFACT
E31	Square metre per litre A unit of count defining the number of square metres per litre. EDIFACT
E32	Litre per hour A unit of count defining the number of litres per hour. EDIFACT
E34	Gigabyte A unit of information equal to 10 E9 bytes.
E37	Pixel A unit of count defining the number of pixels (pixel: picture element).
E38	Megapixel A unit of count equal to 10 E6 (1000000) pixels (picture elements).
E39	Dots per inch A unit of information defining the number of dots per linear inch as a measure of the resolution or sharpness of an image. GS1 Description: synonym: pixels per inch.
EA	each
EV	envelope GS1 Description: A unit of measure pertaining to the number of envelopes.
FAH	degree Fahrenheit
FOT	foot GS1 Description: Foot (0,3048 m)
FP	Pound per square foot A unit of measure expressed in pound per square foot
FTK	Square foot A unit of measure expressed in square foot
FTQ	cubic foot

Used Codes

GL	gram per litre
GLI	gallon (UK) GS1 Description: Gallon (4,546092 dm ³)
GM	gram per square metre GS1 Description: Unit of measure of grams per square metre.
GRM	gram
GRO	gross GS1 Description: A unit of measure of 12 dozens.
GV	gigajoule
GWH	gigawatt hour GS1 Description: Gigawatt-hour (1 million kW/h)
H87	Piece A unit of count defining the number of pieces (piece: a single item, article or exemplar). EDIFACT
HLT	hectolitre
HMT	hectometre A unit of linear measure equal to 10 E2 metres.
HTZ	hertz GS1 Description: One cycle per second.
HUR	hour
INH	inch GS1 Description: Inch (25,4 mm)
INK	Square inch A unit of measure expressed in square inch
JM	Megajoule per cubic metre EDIFACT
JOU	joule
K51	Kilocalorie (mean) EDIFACT
KB	kilocharacter
KBA	kilobar
KEL	kelvin
KGM	kilogram

Used Codes

KHZ	kilohertz
KJO	kilojoule
KL	kilogram per metre GS1 Description: A measure of weight in terms of kilogram per metre.
KMH	kilometre per hour GS1 Description: A unit of measure expressed in kilometre per hour.
KMQ	kilogram per cubic metre GS1 Description: A measure of weight in terms of kilogram per cubic metre.
KMT	kilometre
KPA	kilopascal GS1 Description: Unit of measure expressed in kilopascal.
KVA	kilovolt - ampere GS1 Description: A unit of electric power.
KVT	kilovolt
KWH	kilowatt hour
KWT	kilowatt
L2	litre per minute GS1 Description: Unit of measure expressed in litre per minute.
LBR	Pound EDIFACT
LD	Litre per day A unit of measure defining the number of litres per day.
LNE	Printed line count (GS1 Temporary Code) The indication of the count of printed lines included on a paper communication (e.g. telegram) for invoicing purposes.
LTR	litre GS1 Description: Litre (1 dm ³)
LUX	lux GS1 Description: Unit of measure of illumination (it corresponds to the illumination of a surface which normally and uniformly receives a light flow of 1 lumen per square meter).
M4	Monetary value A unit of measure expressed as a monetary amount. EDIFACT

Used Codes

MAL	mega litre
MAW	megawatt
MC	microgram One millionth of a gram.
MCU	millicurie GS1 Description: Unit of measure for radioactivity.
MGM	milligram
MHZ	megahertz
MIN	minute
MLT	millilitre
MMK	square millimetre GS1 Description: A unit to measure a surface equal to one millionth of a quadrate.
MMQ	cubic millimetre GS1 Description: A unit of measure expressed in cubic milimetres.
MMT	millimetre
MON	month GS1 Description: The expression of a month as a measure unit.
MPA	megapascal GS1 Description: A unit of measure expressed in Megapascal.
MQH	Cubic metre per hour A unit of measure defining the number of cubic metres per hour.
MTK	square metre
MTQ	cubic metre
MTR	metre
MTS	Metre per second A unit of speed expressed in metres per second.
MWH	megawatt hour (1000 kW.h)
NAR	number of articles
NEW	newton GS1 Description: The SI unit of force, equal to the force that would give a mass of one kilogram an acceleration of one metre per second.
NIU	number of international units A unit of count defining the number of international units.

Used Codes

NRL	number of rolls
ONZ	ounce GS1 Description: Ounce GB, US (28,349523 g)
OZA	fluid ounce (US) GS1 Description: Fluid ounce US (29,5735 cm ³)
OZI	fluid ounce (UK) GS1 Description: Fluid ounce UK (28,413 cm ³)
P1	percent GS1 Description: This code is used to indicate measurements in terms of percentages, e.g. the relative humidity (code RA in data element 6313) is 52%.
PA	packet
PAL	pascal GS1 Description: The SI unit of pressure, equal to one Newton per square metre.
PCE	Piece (GS1 Temporary Code) GS1 Note: Old code value. Use value H87 instead.
PF	pallet (lift) GS1 Description: A number of articles expressed in terms of pallets.
PR	pair GS1 Description: Two articles which belong together but are not necessarily identical.
PTI	pint (UK) GS1 Description: Pint UK (0,568262 dm ³)
PTN	Portion (GS1 Temporary Code) The identification of the number of portions (doses in medical terms) into which a complete product may be broken into for serving purposes, e.g. a pie with 6 portions, a liquid medicine with 20 doses.
QAN	quarter (of a year)
QTI	quart (UK) GS1 Description: Quart UK (1,1136523 dm ³)
RJH	Decanewton (GS1 Temporary Code) A unit of force equal to 10 Newton.
RPM	revolutions per minute
RTO	Ratio (GS1 Temporary Code) The measured value is a ratio.

Used Codes

SEC	second
SMI	Mile (statute mile) A unit of measure expressed in mile
ST	sheet
TNE	tonne (metric ton) GS1 Description: Metric ton (1000kg)
U2	tablet A unit of count defining the number of tablets (tablet: a small flat or compressed solid object). GS1 Description: Dosage form for pharmaceuticals, pressed or compacted from a powder into a solid dose.
UI	Unit of activity, predefined (GS1 Temporary Code) A measure pertaining to a predefined activity.
VI	vial GS1 Description: Small glass container. E.g. for a liquid medicine or perfume.
VLT	volt
WHR	watt hour
WTT	watt
YDK	Square yard A unit of measure expressed in square yard
YRD	yard GS1 Description: Yard (0,9144 m)
ZP	page GS1 Description: The indication of a page as a measurement unit for invoicing purposes, e.g. fax pages.
7009	Item description code Code specifying an item.
ACA	ABC Method - Classification A (GS1 Permanent Code) Activity based on costing classification method A.
ACB	ABC Method - Classification B (GS1 Permanent Code) Activity based on costing classification method B.
ACC	ABC Method - Classification C (GS1 Permanent Code) Activity based on costing classification method C.

Used Codes

AUT	Autumn (GS1 Permanent Code) Autumn season.
BA	Base article (GS1 Permanent Code) A conceptual article identified for the purposes of ordering Customer Specific Articles. Base articles must always have configurations of options associated with them.
BLK	Bulk consumer unit (GS1 Permanent Code) The item is designed as a bulk consumer unit, i.e. to be sold mainly to hotels, restaurants, caterers, hospitals etc.
BU	Base unit (GS1 Permanent Code) The lowest level packaged unit for a given product, which may or may not be the consumer unit.
CA	Case (GS1 Permanent Code) A standard trade item shipping unit.
CIT	Collateral Item (GS1 Permanent Code) A trade item delivered from a manufacturer to the retail selling floor that is not considered inventory and has no retail value.
CMP	Composition (GS1 Permanent Code) The item is included in a dynamic assortment.
CSF	Display material (GS1 Permanent Code) A shopping unit that is a display.
CSG	Full display stand (GS1 Permanent Code) A trade item given to a consumer as part of a promotional event on another item or items.
CTO	Cut to order (GS1 Permanent Code) A unit load that is a "display ready pallet" and is intended to go directly to the selling floor.
CU	Consumer unit (GS1 Permanent Code) A group of trade items (the same or different) that are intended to be sold as a single consumer unit at the Point-of-Sale.
D	Available all the year round (GS1 Permanent Code) A unit load that could contain multiple packages.
DAS	Dynamic Assortment (GS1 Permanent Code) The item is included in a dynamic assortment.
DF	Default (GS1 Permanent Code) A logistical unit or a consumer unit between a case and a each.
DIC	Discount coupon (GS1 Permanent Code) A coupon that entitles to a discount.

Used Codes

DSP	Display shipper (GS1 Permanent Code) A shopping unit that is a display.
DST	Display stand (GS1 Permanent Code) A trade item given to a consumer as part of a promotional event on another item or items.
DU	Despatch unit (GS1 Permanent Code) The package size of a product or products which may be shipped when fulfilling an order.
ETO	Engineer to Order (GS1 Permanent Code) Engineer to Order includes products that are designed, developed and manufactured in response to a specific customer request.
F01	Caught (GS1 Permanent Code) Caught at sea
F02	Caught in freshwater (GS1 Permanent Code) Caught in freshwater
F03	Farmed (GS1 Permanent Code) Farmed
F04	Cultivated (GS1 Permanent Code) Cultivated
FEM	Female (GS1 Permanent Code) Female gender.
FS	Available in spring-summer (GS1 Permanent Code) The product is available in the spring-summer period.
FZ1	Previously frozen (GS1 Permanent Code) Previously frozen
FZ2	Not previously frozen (GS1 Permanent Code) Not previously frozen
GWP	Gift with purchase (GS1 Permanent Code) A trade item given to a consumer as part of a promotional event on another item or items.
HN	Handling unit (GS1 Permanent Code) The package size of a product which will be used when transporting and storing the product.
HW	Available in autumn-winter (GS1 Permanent Code) The product is available in the autumn-winter period.
IF1	IF <> THEN <> ENDIF (GS1 Permanent Code) E.G., IF <customer chooses node number 1332> THEN <action (taken from DE 1229 of LIN) to node number 1773> ENDIF.

Used Codes

IF2	IF NOT <> THEN <> ENDIF (GS1 CPermanent ode) E.G., IF NOT <customer does not choose node number 1332> THEN <action (taken from DE 1229 of LIN) to node number 1773> ENDIF.
IF3	IF <> AND (GS1 Permanent Code) E.G., IF <customer chooses node number 1332> AND (followed by another repeat of IMD with another rule).
IF4	IF NOT <> AND (GS1 Permanent Code) E.G., IF NOT <customer does not choose node number 1332> AND (followed by another repeat of IMD with another rule).
IF5	IF <> OR (GS1 Permanent Code) E.G., IF <customer chooses node number 1332> OR (followed by another repeat of IMD with another rule).
IF6	IF NOT <> OR (GS1 Permanent Code) E.G., IF NOT <customer does not choose node number 1332> OR (followed by another repeat of IMD with another rule).
IF7	IF <> XOR (GS1 Permanent Code) E.G., IF <customer chooses node number 1332> XOR (followed by another repeat of IMD with another rule).
IF8	IF NOT <> XOR (GS1 Permanent Code) E.G., IF NOT <customer does not choose node number 1332> XOR (followed by another repeat of IMD with another rule).
IN	Invoicing unit (GS1 Permanent Code) The package size of a product or products which will be used as the unit on which the buyer is invoiced.
IT	Intermediate unit (GS1 Permanent Code) A package size of a product or products falling in between two predefined package sizes.
MA	Mandatory (GS1 Permanent Code) An option of a Customer Specific Article which is mandatory in the configuration of the base article, e.g. it is mandatory to have legs when ordering a CSA table.
MAL	Male (GS1 Permanent Code) Male gender.
MM	Mixed module (GS1 Permanent Code) A unit load that is a "display ready pallet" and is intended to go directly to the selling floor.
MOD	Model (GS1 Permanent Code) The identification of an article as a high level model of a product, e.g. spring fashions.

Used Codes

MP	<p>Multipack (GS1 Permanent Code)</p> <p>A group of trade items (the same or different) that are intended to be sold as a single consumer unit at the Point-of-Sale.</p>
MTO	<p>Make to Order (GS1 Permanent Code)</p> <p>A Make to Order environment is one in which products are completed after receipt of a customer order and are built or configured only in response to a customer order.</p>
MTS	<p>Make to Stock (GS1 Permanent Code)</p> <p>Make to Stock products are intended to be shipped from finished goods or 'off the shelf', are completed prior to receipt of a customer order, and are generally produced in accordance with sales forecasts.</p>
NAR	<p>Next Article (GS1 Permanent Code)</p> <p>An indication that what follows is a set of linked articles, a certain number of these linked articles should be chosen.</p>
NBU	<p>Not a base unit (GS1 Permanent Code)</p> <p>Not the lowest level packaged unit for a given product, which may or may not be the consumer unit.</p>
NCU	<p>Not a consumer unit (GS1 Permanent Code)</p> <p>The current base item or packaging item is not a consumer unit, i.e. is not a pre-packaging that is intended and labelled or marked for consumers according to legal requirements.</p>
ND	<p>Non divisible item (GS1 Permanent Code)</p> <p>The item is not divisible.</p>
NDU	<p>Not a despatch unit (GS1 Permanent Code)</p> <p>The current base item or packaging item is not a regular logistical despatch unit, i.e. it is as a rule only delivered as many within a further repackaging, and not as an individual logistics item.</p>
NFR	<p>Not For Resale (GS1 Permanent Code)</p> <p>Item is not for resale to consumer.</p>
NIN	<p>Not an invoicing unit (GS1 Permanent Code)</p> <p>The current base item or packaging item is not an invoicing unit of the data supplier, i.e. cannot be invoiced individually but only as one of many in a repackaging or transport packaging item.</p>
NLK	<p>Not a bulk consumer unit (GS1 Permanent Code)</p> <p>The item is not designed as a bulk consumer unit, i.e. to be sold mainly to hotels, restaurants, caterers, hospitals etc.</p>
NO	<p>Not an ordering unit (GS1 Permanent Code)</p> <p>A package size of a product or products which may not be ordered.</p>
NOS	<p>Yes, NOS item (GS1 Permanent Code)</p> <p>The current item is an NOS (Never out of stock) article, that is continuously reordered and replenished.</p>

Used Codes

NOT	Not, not an NOS item (GS1 Permanent Code) The current item is not an NOS (Never out of stock) article, therefore is not continuously reordered and replenished.
NOV	Next option value (GS1 Permanent Code) An indication that what follows is a set of linked option values, next option values, or parameters.
NPC	Reusable container, but not standardized by a pool cooperative (GS1 Permanent Code) Reusable container that is not standardized by a pool cooperative.
NRC	Non-returnable container (GS1 Permanent Code) The current product is not traditionally a traded product and does not need to be returned to the sender.
NRE	Not a retail product (GS1 Permanent Code) The current item is not meant for retail sale, but only for sale to hotels, restaurants and catering.
NS	Not smallest unit (GS1 Permanent Code) Not the smallest unit for a given product.
NSU	Non-standard unit (GS1 Permanent Code) Products grouped together to fulfil specific ordering needs and not generally available.
NVQ	Not a variable quantity product (GS1 Permanent Code) The current item is a variable weight trade item, for which the weight and the quantity is determined only by the buyer.
OP	Option (GS1 Permanent Code) An option within a Customer Specific Article which does not exist on its own, e.g. colour, and which has discrete values.
OPL	Overall product level (GS1 Permanent Code) An overall level whereby many products are grouped on the basis of their composition, application and characteristics (e.g. Coca Cola with no size, packaging, price, etc, specified).
OPV	Option value (GS1 Permanent Code) The result of a choice of an option. The option value will be the lowest level of a branch beneath an option structure.
ORU	Ordering unit (GS1 Permanent Code) Indication that the current product is an ordering unit (ordering unit will not normally equal invoicing unit).
PA	Numeric parameter (GS1 Permanent Code) An option of a Customer Specific Article which has a continuous numeric value, e.g., measurement of the length of a chair leg between 60cms and 80cms.

Used Codes

PAA	Alpha-numeric parameter (GS1 Permanent Code) An option of a Customer Specific Article which has a continuous alpha-numeric value, e.g., words and numbers to be embroidered into a cushion cover.
PAD	Promotional article description (GS1 Permanent Code) Description of a promotional article.
PAL	Pallet (GS1 Permanent Code) A unit load that could contain multiple packages.
PAS	Prepack assortment (GS1 Permanent Code) Contains multiple components, each of which represents a unique consumer unit item.
PIP	Packer or inner pack (GS1 Permanent Code) A logistical unit or a consumer unit between a case and a each.
PPK	Prepack (GS1 Permanent Code) Contains multiple components, each of which represents a unique consumer unit item.
PR1	Bonus Pack (GS1 Permanent Code) The free quantity promotional trade item contains free additional quantities. The additional quantity is written on the package as free.
PR2	Free components (GS1 Permanent Code) It contains free included components or material. The price is lower since the trade item includes a part of its content free. The free quantity is written on the package.
PR3	Free quantity (GS1 Permanent Code) It contains free quantity, a "special offer" sticker on the package indicates the promotional offer but the free quantity is not written on the package. If the free quantity promotional offer results in a change of GTIN and the quantity of product is the same as the standard trade item, it qualifies as a free quantity promotional trade item. The linkage has to be provided.
PR4	Multi-pack and combination pack (GS1 Permanent Code) It is a promotional grouping with included free quantity. The grouping is created for promotional activities only. In the grouping a part of the quantity is free.
PRO	Programme (GS1 Permanent Code) A programme within a Customer Specific Article which does not exist on its own.
PWP	Purchase with purchase (GS1 Permanent Code) A trade item sold to a consumer at a special price as part of a promotional event, contingent on the consumer purchasing another item or items.
RC	Returnable container (GS1 Permanent Code) The current product is not traditionally a traded product but one which should be returned according to separate instructions.

Used Codes

RD	Refundable deposit item (GS1 Permanent Code) Item is subject to a refundable deposit.
RE	Retail product (GS1 Permanent Code) The current item is meant for retail sale only, and not for sale to hotels, restaurants and catering.
RPC	Reusable pool container (GS1 Permanent Code) Reusable container standardized by a pool cooperative.
SER	Service (GS1 Permanent Code) A code identifying the current item as a service (i.e. not a physical product).
SG	Standard group of products (mixed assortment) (GS1 Permanent Code) A standard package containing different products enabling the package to be ordered, delivered and invoiced.
SMR	Summer (GS1 Permanent Code) Summer season.
SPK	Setpack (GS1 Permanent Code) Contains multiple components, each of which represents a unique consumer unit item.
SPR	Spring (GS1 Permanent Code) Spring season.
SU	Smallest unit (GS1 Permanent Code) The smallest usable or tradeable size or unit for a given product.
TU	Traded unit (GS1 Permanent Code) The package size of a product or products which has been agreed by trading partners as the size which may be ordered, delivered and invoiced.
UNI	Unisex (GS1 Permanent Code) No gender.
VQ	Variable quantity product (GS1 Permanent Code) Product is used or traded in continuous rather than discrete quantities.
WNT	Winter (GS1 Permanent Code) Winter season.
XX1	Count (GS1 Permanent Code) The measure applied to price is count.
XX2	Area (GS1 Permanent Code) The measure applied to price is area.
XX3	Weight (GS1 Permanent Code) The measure applied to price is weight.
XX4	Volume (GS1 Permanent Code) The measure applied to price is volume.

Used Codes

XX5	Length (GS1 Permanent Code) The measure applied to price is length.
XX6	Loose (GS1 Permanent Code) A trade item which is without packaging at the retail level.
XX7	Pre-packed (GS1 Permanent Code) A variable-measure trade item which is provided with packaging that is assembled or produced by the supplier or by the retailer in advance of sale to the consumer.
XX8	Fixed discount coupon on item price (GS1 Permanent Code) A discount coupon that can be redeemed at the point of sale for a fixed amount when purchasing a specific item/brand/range.
XX9	Fixed discount coupon on purchase amount (GS1 Permanent Code) A discount coupon that can be redeemed at the point of sale for a fixed amount on the total amount of the purchase.
XY1	Percentage discount on item price (GS1 Permanent Code) A discount coupon that can be redeemed at the point of sale for a percentage of the specific item/brand/range value.
XY2	Percentage discount on purchase amount (GS1 Permanent Code) A discount coupon that can be redeemed at the point of sale for a percentage of the total amount of the purchase.
XY3	Meal voucher (GS1 Permanent Code) Fixed amount voucher that can be redeemed at foodservice industry.
XY4	Limited Edition (GS1 Permanent Code) A product with limited edition is restricted in the number of copies produced, although in fact the number may be very low or very high. A special edition implies there is extra material of some kind included.
XY5	One Shot Product (GS1 Permanent Code) The trading partners agree to supply/buy this product only once. Afterwards this product will not be supplied/bought any more.
XY6	Fee (GS1 Permanent Code) Code identify the GTIN of LIN segment as being fees.
XY7	Brokerage (GS1 Permanent Code) Code identify the GTIN of LIN segment as being brokerages.
XY8	Transport medium unit (GS1 Permanent Code) Code identify the position as a Transport Medium Unit (Pallet, Container, ...).
XY9	Counted measurand factor (GS1 Permanent Code) Factor for price calculation of energy products, e.g. gas, fuel.
XZ1	Standard condition conversion (GS1 Permanent Code) The ratio of a product volume (e.g. gas) in standard conditions to the volume in the operating state.

Used Codes

XZ2	Calorific value (GS1 Permanent Code) The calorific value of a fuel indicates the amount of heat generated by the combustion and subsequent cooling of the combustion gases at 25 degrees Celsius.
XZ3	Food contact allowed (GS1 Temporary Code) The trade item is allowed to have direct contact with food.
XZ4	Food contact not allowed (GS1 Temporary Code) The trade item is not allowed to have direct contact with food.
7065	Package type description code Code specifying the type of package. Notes: 1. Recommend use UN/ECE Recommendation No. 21 (also, see current volume of UNTDED).
43	Bag, super bulk
44	Bag, polybag A type of plastic bag, typically used to wrap promotional pieces, publications, product samples, and/or catalogues.
1A	Drum, steel
1B	Drum, aluminium
1D	Drum, plywood
1F	Container, flexible A packaging container of flexible construction.
1G	Drum, fibre
1W	Drum, wooden
2C	Barrel, wooden
3A	Jerrican, steel
3H	Jerrican, plastic
4A	Box, steel
4B	Box, aluminium
4C	Box, natural wood
4D	Box, plywood
4F	Box, reconstituted wood
4G	Box, fibreboard
4H	Box, plastic
5H	Bag, woven plastic

Used Codes

5L	Bag, textile
5M	Bag, paper
6H	Composite packaging, plastic receptacle
6P	Composite packaging, glass receptacle
7A	Case, car A type of portable container designed to store equipment for carriage in an automobile.
7B	Case, wooden A case made of wood for retaining substances or articles.
8A	Pallet, wooden A platform or open-ended box, made of wood, on which goods are retained for ease of mechanical handling during transport and storage.
8B	Crate, wooden A receptacle, made of wood, on which goods are retained for ease of mechanical handling during transport and storage.
8C	Bundle, wooden Loose or unpacked pieces of wood tied or wrapped together.
AA	Intermediate bulk container, rigid plastic
AB	Receptacle, fibre
AC	Receptacle, paper
AD	Receptacle, wooden
AE	Aerosol
AF	Pallet, modular, collars 80cms × 60cms
AG	Pallet, shrinkwrapped
AH	Pallet, 100cms × 110cms
AI	Clamshell
AJ	Cone
AL	Ball A spherical containment vessel for retaining substances or articles.
AM	Ampoule, non-protected
AP	Ampoule, protected
AT	Atomizer
AV	Capsule
B4	Belt A band use to retain multiple articles together.
BA	Barrel

Used Codes

BB	Bobbin
BC	Bottlecrate / bottlerack
BD	Board
BE	Bundle
BF	Balloon, non-protected
BG	Bag
BH	Bunch
BI	Bin
BJ	Bucket
BK	Basket
BL	Bale, compressed
BM	Basin
BN	Bale, non-compressed
BO	Bottle, non-protected, cylindrical
BP	Balloon, protected
BQ	Bottle, protected cylindrical
BR	Bar
BS	Bottle, non-protected, bulbous
BT	Bolt
BU	Butt
BV	Bottle, protected bulbous
BW	Box, for liquids
BX	Box
BY	Board, in bundle/bunch/truss
BZ	Bars, in bundle/bunch/truss
CA	Can, rectangular
CB	Crate, beer
CC	Churn
CD	Can, with handle and spout
CE	Creel
CF	Coffer
CG	Cage
CH	Chest

Used Codes

CI	Canister
CJ	Coffin
CK	Cask
CL	Coil
CM	Card
CN	Container, not otherwise specified as transport equipment
CO	Carboy, non-protected
CP	Carboy, protected
CQ	Cartridge
CR	Crate
CS	Case
CT	Carton
CU	Cup
CV	Cover
CW	Cage, roll
CX	Can, cylindrical
CY	Cylinder
CZ	Canvas
DA	Crate, multiple layer, plastic
DB	Crate, multiple layer, wooden
DC	Crate, multiple layer, cardboard
DG	Cage, Commonwealth Handling Equipment Pool (CHEP)
DH	Box, Commonwealth Handling Equipment Pool (CHEP), Eurobox
DI	Drum, iron
DJ	Demijohn, non-protected
DK	Crate, bulk, cardboard
DL	Crate, bulk, plastic
DM	Crate, bulk, wooden
DN	Dispenser
DP	Demijohn, protected
DR	Drum
DS	Tray, one layer no cover, plastic
DT	Tray, one layer no cover, wooden

Used Codes

DU	Tray, one layer no cover, polystyrene
DV	Tray, one layer no cover, cardboard
DW	Tray, two layers no cover, plastic tray
DX	Tray, two layers no cover, wooden
DY	Tray, two layers no cover, cardboard
EC	Bag, plastic
ED	Case, with pallet base
EE	Case, with pallet base, wooden
EF	Case, with pallet base, cardboard
EG	Case, with pallet base, plastic
EH	Case, with pallet base, metal
EI	Case, isothermic
EN	Envelope
FB	Flexibag A flexible containment bag made of plastic, typically for the transportation bulk non-hazardous cargoes using standard size shipping containers.
FC	Crate, fruit
FD	Crate, framed
FE	Flexitank A flexible containment tank made of plastic, typically for the transportation bulk non-hazardous cargoes using standard size shipping containers.
FI	Firkin
FL	Flask
FO	Footlocker
FP	Filmpack
FR	Frame
FT	Foodtainer
FW	Cart, flatbed Wheeled flat bedded device on which trays or other regular shaped items are packed for transportation purposes.
FX	Bag, flexible container
GB	Bottle, gas
GI	Girder
GL	Container, gallon A container with a capacity of one gallon.

Used Codes

GR	Receptacle, glass
GU	Tray, containing horizontally stacked flat items Tray containing flat items stacked on top of one another.
GY	Bag, gunny A sack made of gunny or burlap, used for transporting coarse commodities, such as grains, potatoes, and other agricultural products.
GZ	Girders, in bundle/bunch/truss
HA	Basket, with handle, plastic
HB	Basket, with handle, wooden
HC	Basket, with handle, cardboard
HG	Hogshead
HN	Hanger A purpose shaped device with a hook at the top for hanging items from a rail.
HR	Hamper
IA	Package, display, wooden
IB	Package, display, cardboard
IC	Package, display, plastic
ID	Package, display, metal
IE	Package, show
IF	Package, flow
IG	Package, paper wrapped
IH	Drum, plastic
IK	Package, cardboard, with bottle grip-holes
IL	Tray, rigid, lidded stackable (CEN TS 14482:2002) Lidded stackable rigid tray compliant with CEN TS 14482:2002.
IN	Ingot
IZ	Ingots, in bundle/bunch/truss
JB	Bag, jumbo A flexible containment bag, widely used for storage, transportation and handling of powder, flake or granular materials. Typically constructed from woven polypropylene (PP) fabric in the form of cubic bags.
JC	Jerrican, rectangular
JG	Jug
JR	Jar
JT	Jutebag

Used Codes

JY	Jerrican, cylindrical
KG	Keg
KI	Kit A set of articles or implements used for a specific purpose.
LE	Luggage A collection of bags, cases and/or containers which hold personal belongings for a journey.
LG	Log
LT	Lot
LU	Lug A wooden box for the transportation and storage of fruit or vegetables.
LV	Liftvan
LZ	Logs, in bundle/bunch/truss
MA	Crate, metal Containment box made of metal for retaining substances or articles.
MB	Bag, multiply
MC	Crate, milk
ME	Container, metal A type of containment box made of metal for retaining substances or articles, not otherwise specified as transport equipment.
MR	Receptacle, metal
MS	Sack, multi-wall
MT	Mat
MW	Receptacle, plastic wrapped
MX	Matchbox
NA	Not available
NE	Unpacked or unpackaged
NF	Unpacked or unpackaged, single unit
NG	Unpacked or unpackaged, multiple units
NS	Nest
NT	Net
NU	Net, tube, plastic
NV	Net, tube, textile

Used Codes

O1	Two sided cage on wheels with fixing strap A two sided cage mounted on wheels with fixing strap. Dimensions: 900 x 770 x 1513 cm (length x width x height).
O2	Trolley A low cart for the transportation and storage of groceries, milk, etc.
O3	Oneway pallet ISO 0 - 1/2 EURO Pallet Oneway pallet with dimensions 80 X 60 cm.
O4	Oneway pallet ISO 1 - 1/1 EURO Pallet Oneway pallet with dimensions 80 X 120 cm.
O5	Oneway pallet ISO 2 - 2/1 EURO Pallet Oneway pallet with dimensions 100 X 120 cm.
O6	Pallet with exceptional dimensions Pallet with non-standard dimensions.
OA	Pallet, CHEP 40 cm x 60 cm CHEP standard pallet of dimensions 40 centimeters x 60 centimeters.
OB	Pallet, CHEP 80 cm x 120 cm CHEP standard pallet of dimensions 80 centimeters x 120 centimeters.
OC	Pallet, CHEP 100 cm x 120 cm CHEP standard pallet of dimensions 100 centimeters x 120 centimeters.
OD	Pallet, AS 4068-1993 Australian standard pallet of dimensions 115.5 centimeters x 116.5 centimeters.
OE	Pallet, ISO T11 ISO standard pallet of dimensions 110 centimeters x 110 centimeters, prevalent in Asia - Pacific region.
OF	Platform, unspecified weight or dimension A pallet equivalent shipping platform of unknown dimensions or unknown weight.
OG	Pallet ISO 0 - 1/2 EURO Pallet Standard pallet with dimensions 80 X 60 cm.
OH	Pallet ISO 1 - 1/1 EURO Pallet Standard pallet with dimensions 80 X 120 cm.
OI	Pallet ISO 2 - 2/1 EURO Pallet Standard pallet with dimensions 100 X 120 cm.
OJ	1/4 EURO Pallet Standard pallet with dimensions 60 X 40 cm.

Used Codes

OK	Block A solid piece of a hard substance, such as granite, having one or more flat sides.
OL	1/8 EURO Pallet Standard pallet with dimensions 40 X 30 cm.
OM	Synthetic pallet ISO 1 A standard pallet with standard dimensions 80 x 120cm made of a synthetic material for hygienic reasons.
ON	Synthetic pallet ISO 2 A standard pallet with standard dimensions 100 x 120cm made of a synthetic material for hygienic reasons.
OP	Wholesaler pallet Pallet provided by the wholesaler.
OQ	Pallet 80 X 100 cm Pallet with dimensions 80 X 100 cm.
OR	Pallet 60 X 100 cm Pallet with dimensions 60 X 100 cm.
OS	Oneway pallet Pallet need not be returned to the point of expedition.
OT	Octabin A standard cardboard container of large dimensions for storing for example vegetables, granules of plastics or other dry products.
OU	Container, outer A type of containment box that serves as the outer shipping container, not otherwise specified as transport equipment.
OV	Returnable pallet Pallet must be returned to the point of expedition.
OW	Large bag, pallet sized A non-rigid container made of fabric, paper, plastic, etc, with an opening at the top which can be closed and which is suitable for use on pallets.
OX	A wheeled pallet with raised rim (81 x 67 x 135) A wheeled pallet with raised rim for the storing and transporting of loads. Dimensions: 81 x 67 x 135 cm (length x width x height).
OY	A wheeled pallet with raised rim (81 x 72 x 135) A wheeled pallet with raised rim for the storing and transporting of loads. Dimensions: 81 x 72 x 135 cm (length x width x height).
OZ	A wheeled pallet with raised rim (81 x 60 x 16) A wheeled pallet with raised rim for the storing and transporting of loads. Dimensions: 81 x 60 x 16 cm (length x width x height).

Used Codes

P2	Pan A shallow, wide, open container, usually of metal.
PA	Packet
PB	Pallet, box
PC	Parcel
PD	Pallet, modular, collars 80cms * 100cms
PE	Pallet, modular, collars 80cms * 120cms
PF	Pen
PG	Plate
PH	Pitcher
PI	Pipe
PJ	Punnet
PK	Package
PL	Pail
PN	Plank
PO	Pouch
PP	Piece A loose or unpacked article.
PR	Receptacle, plastic
PT	Pot
PU	Tray pack
PV	Pipes, in bundle/bunch/truss
PX	Pallet
PY	Plates, in bundle/bunch/truss
PZ	Planks, in bundle/bunch/truss
QA	Drum, steel, non-removable head
QB	Drum, steel, removable head
QC	Drum, aluminium, non-removable head
QD	Drum, aluminium, removable head
QF	Drum, plastic, non-removable head
QG	Drum, plastic, removable head
QH	Barrel, wooden, bung type
QJ	Barrel, wooden, removable head
QK	Jerrican, steel, non-removable head

Used Codes

QL	Jerrican, steel, removable head
QM	Jerrican, plastic, non-removable head
QN	Jerrican, plastic, removable head
QP	Box, wooden, natural wood, ordinary
QQ	Box, wooden, natural wood, with sift proof walls
QR	Box, plastic, expanded
QS	Box, plastic, solid
RD	Rod
RG	Ring
RJ	Rack, clothing hanger
RK	Rack
RL	Reel
RO	Roll
RT	Rednet
RZ	Rods, in bundle/bunch/truss
SA	Sack
SB	Slab
SC	Crate, shallow
SD	Spindle
SE	Sea-chest
SH	Sachet
SI	Skid
SK	Case, skeleton
SL	Slipsheet
SM	Sheetmetal
SO	Spool
SP	Sheet, plastic wrapping
SS	Case, steel
ST	Sheet
SU	Suitcase
SV	Envelope, steel
SW	Shrinkwrapped
SY	Sleeve

Used Codes

SZ	Sheets, in bundle/bunch/truss
T1	Tablet A loose or unpacked article in the form of a bar, block or piece.
TB	Tub
TC	Tea-chest
TD	Tube, collapsible
TE	Tyre A ring made of rubber and/or metal surrounding a wheel.
TG	Tank container, generic A specially constructed container for transporting liquids and gases in bulk.
TI	Tierce TI
TK	Tank, rectangular
TL	Tub, with lid
TN	Tin
TO	Tun
TR	Trunk
TS	Truss
TT	Bag, tote A capacious bag or basket.
TU	Tube
TV	Tube, with nozzle
TW	Pallet, triwall A lightweight pallet made from heavy duty corrugated board.
TY	Tank, cylindrical
TZ	Tubes, in bundle/bunch/truss
UC	Uncaged
UN	Unit A type of package composed of a single item or object, not otherwise specified as a unit of transport equipment.
VA	Vat
VG	Bulk, gas (at 1031 mbar and 15 degree C)
VI	Vial
VK	Vanpack
VL	Bulk, liquid

Used Codes

VN	Vehicle A self-propelled means of conveyance.
VO	Bulk, solid, large particles ("nodules")
VP	Vacuum-packed
VQ	Bulk, liquefied gas (at abnormal temperature/pressure)
VR	Bulk, solid, granular particles ("grains")
VS	Bulk, scrap metal Loose or unpacked scrap metal transported in bulk form.
VY	Bulk, solid, fine particles ("powders")
WA	Intermediate bulk container
WB	Wickerbottle
WC	Intermediate bulk container, steel
WD	Intermediate bulk container, aluminium
WF	Intermediate bulk container, metal
WG	Intermediate bulk container, steel, pressurised > 10 kpa
WH	Intermediate bulk container, aluminium, pressurised > 10 kpa
WJ	Intermediate bulk container, metal, pressure 10 kpa
WK	Intermediate bulk container, steel, liquid
WL	Intermediate bulk container, aluminium, liquid
WM	Intermediate bulk container, metal, liquid
WN	Intermediate bulk container, woven plastic, without coat/liner
WP	Intermediate bulk container, woven plastic, coated
WQ	Intermediate bulk container, woven plastic, with liner
WR	Intermediate bulk container, woven plastic, coated and liner
WS	Intermediate bulk container, plastic film
WT	Intermediate bulk container, textile with out coat/liner
WU	Intermediate bulk container, natural wood, with inner liner
WV	Intermediate bulk container, textile, coated
WW	Intermediate bulk container, textile, with liner
WX	Intermediate bulk container, textile, coated and liner
WY	Intermediate bulk container, plywood, with inner liner
WZ	Intermediate bulk container, reconstituted wood, with inner liner
XA	Bag, woven plastic, without inner coat/liner
XB	Bag, woven plastic, sift proof

Used Codes

XC	Bag, woven plastic, water resistant
XD	Bag, plastics film
XF	Bag, textile, without inner coat/liner
XG	Bag, textile, sift proof
XH	Bag, textile, water resistant
XJ	Bag, paper, multi-wall
XK	Bag, paper, multi-wall, water resistant
YA	Composite packaging, plastic receptacle in steel drum
YB	Composite packaging, plastic receptacle in steel crate box
YC	Composite packaging, plastic receptacle in aluminium drum
YD	Composite packaging, plastic receptacle in aluminium crate
YF	Composite packaging, plastic receptacle in wooden box
YG	Composite packaging, plastic receptacle in plywood drum
YH	Composite packaging, plastic receptacle in plywood box
YJ	Composite packaging, plastic receptacle in fibre drum
YK	Composite packaging, plastic receptacle in fibreboard box
YL	Composite packaging, plastic receptacle in plastic drum
YM	Composite packaging, plastic receptacle in solid plastic box
YN	Composite packaging, glass receptacle in steel drum
YP	Composite packaging, glass receptacle in steel crate box
YQ	Composite packaging, glass receptacle in aluminium drum
YR	Composite packaging, glass receptacle in aluminium crate
YS	Composite packaging, glass receptacle in wooden box
YT	Composite packaging, glass receptacle in plywood drum
YV	Composite packaging, glass receptacle in wickerwork hamper
YW	Composite packaging, glass receptacle in fibre drum
YX	Composite packaging, glass receptacle in fibreboard box
YY	Composite packaging, glass receptacle in expandable plastic pack
YZ	Composite packaging, glass receptacle in solid plastic pack
ZA	Intermediate bulk container, paper, multi-wall
ZB	Bag, large
ZC	Intermediate bulk container, paper, multi-wall, water resistant
ZD	Intermediate bulk container, rigid plastic, with structural equipment, solids

Used Codes

ZF	Intermediate bulk container, rigid plastic, freestanding, solids
ZG	Intermediate bulk container, rigid plastic, with structural equipment, pressurised
ZH	Intermediate bulk container, rigid plastic, freestanding, pressurised
ZJ	Intermediate bulk container, rigid plastic, with structural equipment, liquids
ZK	Intermediate bulk container, rigid plastic, freestanding, liquids
ZL	Intermediate bulk container, composite, rigid plastic, solids
ZM	Intermediate bulk container, composite, flexible plastic, solids
ZN	Intermediate bulk container, composite, rigid plastic, pressurised
ZP	Intermediate bulk container, composite, flexible plastic, pressurised
ZQ	Intermediate bulk container, composite, rigid plastic, liquids
ZR	Intermediate bulk container, composite, flexible plastic, liquids
ZS	Intermediate bulk container, composite
ZT	Intermediate bulk container, fibreboard
ZU	Intermediate bulk container, flexible
ZV	Intermediate bulk container, metal, other than steel
ZW	Intermediate bulk container, natural wood
ZX	Intermediate bulk container, plywood
ZY	Intermediate bulk container, reconstituted wood
ZZ	Mutually defined
08	Oneway pallet (GS1 Temporary Code) Pallet need not be returned to the point of expedition.
09	Returnable pallet (GS1 Temporary Code) Pallet must be returned to the point of expedition.
200	Pallet ISO 0 - 1/2 EURO Pallet (GS1 Temporary Code) Standard pallet with dimensions 80 X 60 cm.
201	Pallet ISO 1 - 1/1 EURO Pallet (GS1 Temporary Code) Standard pallet with dimensions 80 X 120 cm.
202	Pallet ISO 2 (GS1 Temporary Code) Standard pallet with dimensions 100 X 120 cm.
203	1/4 EURO Pallet (GS1 Temporary Code) Standard pallet with dimensions 60 X 40 cm.
204	1/8 EURO Pallet (GS1 Temporary Code) Standard pallet with dimensions 40 X 30 cm.

Used Codes

205	Synthetic pallet ISO 1 (GS1 Temporary Code) A standard pallet with standard dimensions 80*120cm made of a synthetic material for hygienic reasons.
206	Synthetic pallet ISO 2 (GS1 Temporary Code) A standard pallet with standard dimensions 100*120cm made of a synthetic material for hygienic reasons.
210	Wholesaler pallet (GS1 Temporary Code) Pallet provided by the wholesaler.
211	Pallet 80 X 100 cm (GS1 Temporary Code) Pallet with dimensions 80 X 100 cm.
212	Pallet 60 X 100 cm (GS1 Temporary Code) Pallet with dimensions 60 X 100 cm.
AH	Pallet 100cms * 110cms Standard sized pallet of dimensions 100centimeters by 110 centimeters (cms). EDIFACT
AI	Clamshell EDIFACT
APE	Aluminium packed (GS1 Temporary Code) Packaging using thin sheets of aluminium.
BGE	Large bag, pallet sized (GS1 Temporary Code) A non-rigid container made of fabric, paper, plastic, etc, with an opening at the top which can be closed and which is suitable for use on pallets.
BME	Blister pack (GS1 Temporary Code) A transparent strip package of pressable plastic which allows the product to be displayed while remaining protected.
BRI	Brick (GS1 Temporary Code) A box made of a cardboard, plastic or metal, used for liquids.
CBL	Container bottle like (GS1 Temporary Code) A non-protected, non-cylindrical, container with a narrow neck made usually of glass or plastic which is especially used for liquids, e.g. perfume bottle.
CCE	Cardboard carrier (GS1 Temporary Code) A package made of cardboard.
CM	Card A flat package usually made of fibreboard from/to which the product is often hung or attached. EDIFACT
E1	Performance meat container E1 (GS1 Temporary Code) Standard performance meat container with dimensions 60 X 40 X 12,5 cm.
E2	Performance meat container E2 (GS1 Temporary Code) Standard performance meat container with dimensions 60 X 40 X 20 cm.

Used Codes

E3	Performance meat container E3 (GS1 Temporary Code) Standard performance meat container with dimensions 60 X 40 X 30 cm.
FOB	Folding box (GS1 Temporary Code) Folded cardboard box e.g for products like frozen vegetables, paper clips
FPE	Foil packed (GS1 Temporary Code) Packaging using a metallic foil.
LAB	Labeled package (GS1 Temporary Code) The package is labeled. Usually the label identifies the name, brand or description of the product within the package.
MPE	Multipack (GS1 Temporary Code) A container for the merchandising of multiple units of the same product.
OPE	Oxygen packed (GS1 Temporary Code) A package with oxygen added for storage purposes.
PAE	Paper (GS1 Temporary Code) An indication that the item(s) is packed in paper.
PJ	Punnet EDIFACT
PLP	Peel pack (GS1 Temporary Code) A package used for sterile products which may be torn open without touching the product inside.
POP	Cone shaped paper wrapper (GS1 Temporary Code) Cone shaped paper wrapping e.g. for an individually packed ice cream cone.
PPE	Polypropylene bag (GS1 Temporary Code) A bag made from polypropylene.
PUE	Tray packed in plastic (GS1 Temporary Code) A board with a ring packed in plastic carrying for small articles.
RB3	Wheeled pallet with raised rim. 81 x 60 x 16 cm (length x width x height). (GS1 Temporary Code) A wheeled pallet with raised rim for the storing and transporting of loads. Dimensions: 81 x 60 x 16 cm (length x width x height).
RCB	Two sided cage on wheels with fixing strap (GS1 Temporary Code) 900 x 770 x 1513 cm (length x width x height) A two sided cage mounted on wheels with fixing strap. Dimensions: 900 x 770 x 1513 cm (length x width x height).
S1	GS1 SMART-Box Type E (GS1 Temporary Code) Standard reusable crate with dimensions 60 x 40 x 21,1 cm.
SEC	Article Surveillance (GS1 Temporary Code) Equipped with article surveillance.

Used Codes

SO	Spool Any cylindrical piece on which something is wound.
SP	Sheet, plastic wrapping EDIFACT
STL	Stick (GS1 Temporary Code) A container for dispensing solid substances, e.g. glue, deodorant.
T1	Tablet A loose or unpacked article in the form of a bar, block or piece. EDIFACT
TEV	Tamper evident package (GS1 Temporary Code) A type of package giving easy or immediate recognition that the package has been tampered with after it has been sealed.
THE	Three pack (GS1 Temporary Code) A package containing three products.
TL	Tub, with lid EDIFACT
TRE	Trolley (GS1 Temporary Code) A low cart for the transportation and storage of groceries, milk, etc.
TTE	Tube, standing (GS1 Temporary Code) A screw-topped pliable cylinder capable of standing and suitable for holding pastes or semi-liquids, e.g. a tube of toothpaste.
TWE	Two pack (GS1 Temporary Code) A package containing two products.
UUE	Tube net (GS1 Temporary Code) A plastic or textile tube suitable for carrying loose products, e.g. fruit.
UVQ	Wrapped in plastic sheet (GS1 Temporary Code) An indication that the items have been wrapped in plastic sheet.
WRP	Wrapper (GS1 Temporary Code) Wrapping e.g. for an individually packed ice cream.
X11	Banded package (GS1 Temporary Code) A package with bands, usually metal or nylon, round it to hold the products together.
X15	Oneway pallet ISO 0 - 1/2 EURO Pallet (GS1 Temporary Code) Oneway pallet with dimensions 80 X 60 cm.
X16	Oneway pallet ISO 1 - 1/1 EURO Pallet (GS1 Temporary Code) Oneway pallet with dimensions 80 X 120 cm.
X17	Non-standard pallet (GS1 Temporary Code) Non-Standard pallet

Used Codes

X18	Parcel with exceptional dimensions (GS1 Temporary Code) Parcel with non-standard dimensions.
X3	Standard stack of stones (GS1 Temporary Code) Standard stack of stones.
7077	Description format code Code specifying the format of a description.
A	Free-form long description Long description of an item in free form.
B	Code and text Description of an item in coded and free form text.
C	Code (from industry code list) Description of an item in coded format. GS1 Description: Description of an item provided in coded format from an industry list.
D	Free-form price look up Price look-up description of a product for point of sale receipts.
E	Free-form short description Short description of an item in free form.
F	Free-form Description of an item in free form text. GS1 Description: Item related general free form text description, which is neither a short or long description of the item itself.
S	Structured (from industry code list) Description of an item in a structured format.
7081	Item characteristic code Code specifying the characteristic of an item.
2	General product form Description of general product form.
3	Ship to stock Product without quality control when received.
4	Finish Description of the finish required/available on the product.
6	Construction method Description of the method of construction.

Used Codes

13	Quality The degree of excellence of a thing. GS1 Description: Characteristics to be described refer to the quality of the item.
27	Material description Description of material used to manufacture a product. GS1 Description: Free text description of the materials of which the article is composed.
31	European Community risk class European community classification "CE" indicating the safety risk of an article. GS1 Description: European commission classification indicating the safety risk of an article (also called CE-mark or CE-risk class).
35	Colour Description of the colour required/available on the product.
38	Grade Specification of the grade required/available for the product. GS1 Description: Specification of the grade required/available for the product, e.g. the grade of fruit.
44	Further identifying characteristic Description of further identifying characteristic of a product which enables the product to be distinguished from any similar products. GS1 Description: Extra descriptive information in free text which makes it possible to distinguish almost, but not completely, similar articles.
45	Private label name Describes the private label name of a product.
46	Silhouette Describes the outline of the item.
47	Warranty type description The warranty type description of the item.
48	Yarn count Describes the fineness of the yarn in the cloth. GS1 Note: Replaces GS1 Temporary Code U07. EDIFACT
61	New article The characteristic of a new item or commodity.
72	Vintage The harvest year of the grapes that are part of the composition of a particular wine.

Used Codes

75	Artist The performing artist(es) of a recorded song or piece of music.
76	Author The author of a written work.
77	Binding A description of the type of binding used for a written work.
78	Edition Description of the edition of a written work.
79	Other physical description Any other relevant physical description.
80	Publisher The publisher of a written piece of work as part of the item description.
81	Title The title of a work.
82	Series title Title of a series of works.
83	Volume title The title of a volume of work.
84	Composer The composer of a recorded song or piece of music.
85	Recording medium The medium on which a musical recording is made.
86	Music style The style of music.
87	Promotional event Describes the promotional event associated with a product.
98	Size Description of size in non-numeric terms.
120	Chemistry Code indicating the product's chemical characteristics.
126	Pattern Code indicating the product's pattern characteristics.
132	Fabric Code indicating the product's fabric characteristics.
169	Market segment Code indicating the market segment associated with a product.

Used Codes

171	Physical form Code indicating the physical form of a product.
196	Additional sectorial characteristics A code issued on a sectorial basis which identifies any additional characteristics of a product.
197	Product data base management description A description indicating how a product should be managed in a data base.
219	Style A kind, sort, or type that distinguishes one commodity from another commodity with similar characteristics. GS1 Note: Replaces GS1 Temporary Code STE. EDIFACT
223	Brand name The brand name of an item. EDIFACT
ANM	Article name (GS1 Temporary Code) The name of the product.
AVI	Available for ordering (GS1 Temporary Code) Goods are available for ordering.
BPD	Publication date (GS1 Temporary Code) The publication date of a written work as an element of the description.
BVP	Volume or part number (GS1 Temporary Code) The volume or part number of a written work.
DSC	Description (GS1 Temporary Code) A non-structured description of a product.
ECO	ECO labelling description (GS1 Temporary Code) Description of ECO labelling.
EDS	Expiry date surpassed (GS1 Temporary Code) The expiry date for goods has been surpassed.
FGT	Fishing gear type (GS1 Permanent Code) Fishing gear type
FN	Functional Name (GS1 Temporary Code) Describes use of the product or service by the consumer. Should help clarify the product classification associated with the GTIN.
FPC	Fish presentation code (GS1 Permanent Code) Fish presentation code
FQG	Fish quality grade (GS1 Permanent Code) Fish quality grade

Used Codes

FRZ	Freezing information (GS1 Permanent Code) Freezing information
FSS	Fish standardized size (GS1 Permanent Code) Fish standardized size
GDC	GIFAM fault code (GS1 Temporary Code) A code used in the white goods industry to identify faults.
GEO	Geographical area (GS1 Permanent Code) Relevant geographical area.
HAN	Handling instructions (GS1 Temporary Code) A code identifying a coded description of handling instructions.
HAZ	Hazardous material codes (GS1 Temporary Code) A code identifying a coded description of hazardous materials.
IDC	IRIS fault code (GS1 Temporary Code) A code used in the brown goods industry to identify faults.
IN	Invoice name (GS1 Temporary Code) Free form information provider assigned trade item description designed to match trade item/service description as noted on invoices.
IRC	IRIS repair code (GS1 Temporary Code) A code used in the brown goods industry to identify a repair required to correct a fault.
ISC	IRIS section code (GS1 Temporary Code) A code used in the brown goods industry to identify a section containing a fault.
ISY	IRIS symptom code (GS1 Temporary Code) A code used in the brown goods industry to identify a symptom of a fault.
KEY	Keyword (GS1 Temporary Code) A word which may be used as a search key to select items from a product file. A keyword is usually a word which does not exist in the product description but may exist in information accompanying the product, e.g. Keyword = Absorbent, Product description = Gauze dressing, Product information = 1 Peelpack with 10 absorbent gauze dressings.
MNF	Manufacturer (GS1 Temporary Code) The name of the manufacturer of the product which is printed on the product packaging.
NAV	Not available for ordering (GS1 Temporary Code) Goods are not available for ordering.
OFS	Order Fulfilment Strategy (GS1 Temporary Code) The method used by the supplier to fulfil a customer order for a particular product. Three strategies are recognised: Make to Order, Make to Stock and Engineer to Order.

Used Codes

PR	Product Range (GS1 Temporary Code) A name, used by a BrandOwner, that span multiple consumer categories or uses. E.g. (Waist Watchers).
PRO	Production Method (GS1 Permanent Code) Production Method Characteristics.
RLI	Rolling instructions (GS1 Temporary Code) Instructions concerning the rolling of material, e.g. paper, plastic, carpet, etc.
SB	Subbrand (GS1 Temporary Code) Second level of brand. Can be a trademark. It is the primary differentiating factor that a brand owner wants to communicate to the consumer or buyer.
SBN	Primary differentiating factor that a brand owner wants to communicate (GS1 Temporary Code) Second level of brand. Can be a trademark. It is the primary differentiating factor that a brand owner wants to communicate to the consumer or buyer. E. g. Yummy-Cola Classic. In this example Yummy-Cola is the brand and Classic is the subBrand.
SCT	Scientific name (GS1 Permanent Code) The scientific name of a product.
SDS	Shelf description (GS1 Temporary Code) A description of the product for shelf edge labelling purposes.
SGR	Size grid (GS1 Temporary Code) Grid of sizes, containing for a certain type of size (e.g., womans, France, etc) each possible value of the size (e.g., 28, 30, 32, etc).
STE	Style (GS1 Temporary Code) A code identifying the style of a product. GS1 Note: Code marked for deletion. Use value 219 instead.
TDS	Technical description (GS1 Temporary Code) The technical description of a product.
TPE	Article type (GS1 Temporary Code) The article type allocated by the manufacturer to a product.
U02	Fiber (GS1 Temporary Code) A code identifying the fiber contained in a cloth.
U07	Yarn content (GS1 Temporary Code) A code indicating the yarn content of a fabric. GS1 Note: Code marked for deletion. Use value 48 instead.
U08	Roll pattern out (GS1 Temporary Code) An instruction to roll the product with the pattern side facing out.
U09	Roll pattern in (GS1 Temporary Code) An instruction to roll the product with the pattern side facing in.

Used Codes

UP2	Packaging language (GS1 Temporary Code) Language used for package markings.
UP4	Promotional free goods (GS1 Temporary Code) Free goods not associated to any other product given for promotional reasons.
UP5	Width or fitting (GS1 Temporary Code) An indication of the width or fitting (e.g. wide, loose, etc.) of a shoe or textile product.
UP6	Material shoe upper (GS1 Temporary Code) An indication of the material (e.g. leather, suede, canvas, etc.) used to construct a shoe upper.
UP7	Material shoe sole (GS1 Temporary Code) An indication of the material (e.g. leather, rubber, etc.) used to construct the sole of a shoe.
UP8	Material lining (GS1 Temporary Code) An indication of the lining (e.g. silk, leather, etc.) of a shoe or textile product.
UP9	Shoe heel height (GS1 Temporary Code) An indication of the height of the heel of a shoe.
UQ1	Base article exception rule (GS1 Temporary Code) An indication that what follows is a base article exception rule.
UQ2	Orchestra (GS1 Temporary Code) The Orchestra of a recorded song or piece of music.
UQ3	Conductor (GS1 Temporary Code) The conductor of a recorded song or piece of music.
UQ5	Inspection agencies (GS1 Temporary Code) Characteristics to be described refer to inspection agencies controlling the item described.
UQ6	Product without theft protection (GS1 Temporary Code) The product is not fitted with a protection against theft.
UQ7	Product with theft protection, active (GS1 Temporary Code) The product is fitted with a protection against theft that has been activated.
UQ8	Product with theft protection, inactive (GS1 Temporary Code) The product is fitted with a protection against theft that has not been activated.
WVL	Weight or volume loss (GS1 Temporary Code) Goods have suffered a weight or volume loss.
XX1	Collar Type (GS1 Temporary Code) Type of collar on the garment.

Used Codes

XX2	Sleeve Type (GS1 Temporary Code) Type of sleeve on the garment.
XX3	Clothing Cut (GS1 Temporary Code) Code identifying the clothing cut.
XX4	Non marked trade item components (GS1 Temporary Code) Code identifying the of price by measure.
XX5	Campaign name (GS1 Temporary Code) The type of a variable measure trade item.
XX6	Season name (GS1 Temporary Code) Element defines the season applicable to the item.
XX7	Season parameter (GS1 Temporary Code) Indication of the season, in which the trade item is available, i.e. assignment to one of the following collection periods: spring/summer, autumn/ winter or all year around.
XX8	Target Consumer Age (GS1 Temporary Code) Identifies the target consumer age range for which a trade item has been designed.
XX9	Target Consumer Gender (GS1 Temporary Code) Identifies the target consumer gender for which a product has been designed.
XY1	Link to external description (GS1 Temporary Code) The link (e.g. URL) to the external description.
XY2	Additional Trade Item Description (GS1 Temporary Code) Additional variants necessary to communicate to the industry to help define the product. Multiple variants can be established for each GTIN. This is a repeatable field, e.g. Style, Color, and Fragrance.
XY3	Trade item group identification (GS1 Temporary Code) The text description of the value represented by the trade itemGroupIDCode.
XY4	Price by measure type (GS1 Temporary Code) Code identifying the of price by measure.
XY5	Variable trade item type (GS1 Temporary Code) The type of a variable measure trade item.
7143	Item type identification code Coded identification of an item type.
GB	Buyer's internal product group code Product group code used within a buyer's internal systems.
IN	Buyer's item number The item number has been allocated by the buyer.

Used Codes

PV	Promotional variant number The item number is a promotional variant number. GS1 Description: Number supplementing the identification code of a product and identifying that product as a variant of the standard product. To be used when the variation is not sufficiently significant to justify a change fo the main identification code of the product.
SA	Supplier's article number Number assigned to an article by the supplier of that article.
SRV	GS1 Global Trade Item Number A unique number, up to 14-digits, assigned according to the numbering structure of the GS1 system. 'GS1' stands for the 'Global Standards One'.
7161	Special service description code Code specifying a special service.
0	Released (GS1 Temporary Code) Informs the stockholder it is free to distribute the quality controlled passed goods.
1	Quality control held (GS1 Temporary Code) Instructs the stockholder to withhold distribution of the goods until the manufacturer has completed a quality control assessment.
2	Quality controlled embargo (GS1 Temporary Code) Instructs the stockholder to withhold distribution of goods which have failed quality control tests.
AA	Advertising allowance Description to be provided. GS1 Description: Allowance for the advertising costs or activities related to the product.
AAB	Returned goods charges Self-explanatory. GS1 Description: Charges related to the return of goods.
AAJ	Copper surcharge Difference between current price and basic copper value contained in product price.
AAM	Rubber surcharge Difference between current price and basic value contained in product price.
AAT	Rush delivery Charge for increased delivery speed.
AAX	Wolfram surcharge Difference between current price and basic value contained in product price.

Used Codes

AAY	Airport fee Charge associated with usage of airport facilities.
ABA	Compulsory storage fee Fee levied to cover the cost of carrying a certain amount of compulsory inventory (set by regulatory agency).
ABH	Throughput allowance Allowance for reaching or exceeding an agreed throughput threshold.
ABL	Packaging surcharge Additional charge for packaging of items.
ABZ	Miscellaneous rebate or discount Non-defined rebate or discount.
ACQ	Royalty surcharge Additional charge on an item's price for royalty.
ACY	Container deposit charge The charge relating to the packaging of a product in a container when the container is expected to be returned and has value when empty.
ACZ	Damaged merchandise The charge or credit relating to the circumstance of product being damaged and not saleable.
ADM	Binding services A code indicating binding services.
ADN	Repair or replacement of broken returnable package The repair or replacement of a broken returnable package.
ADO	Efficient logistics A code indicating efficient logistics services.
ADP	Merchandising A code indicating that merchandising services are in operation.
ADQ	Product mix A code indicating that product mixing services are in operation.
ADR	Other services A code indicating that other non-specific services are in operation.
ADS	Full pallet ordering Ordering of a full pallet of a product.
ADT	Pick-up For the pick-up or collection of goods.
ADZ	Direct delivery The specification of direct delivery as a special service.

Used Codes

AEK	Cash on delivery service An allowance or charge related to the provision of a cash on delivery service.
AEM	Clerical or administrative services The provision of clerical or administrative services.
AEN	Guarantee service The provision of a guarantee service.
AEO	Collection and recycling service The service of collection and recycling products.
AEP	Copyright fee collection services The service of the collection of copyright fees.
AEQ	Charge for exceeding agreed ordered quantity Charge applicable if the ordered quantity exceeds the quantity that has been agreed upon. GS1 Description: Charge when what the buyer is ordering exceeds the quantity that has been agreed upon.
AES	Veterinary inspection service Allowance or charge related to the service of veterinary inspection.
AEV	Environmental protection service An allowance or charge related to a provision of an environmental protection service. GS1 Description: An allowance or charge related to the provision of environmental protection or clean-up services.
AEX	National cheque processing service outside account area Service of processing a national cheque outside the ordering customer's bank trading area. GS1 Description: Service of processing a domestic cheque in an area, outside that where the ordering customer is holding his account.
AEY	National payment service outside account area Service of processing a national payment to a beneficiary holding an account outside the trading area of the ordering customer's bank.
AEZ	National payment service within account area Service of processing a national payment to a beneficiary holding an account within the trading area of the ordering customer's bank.
AG	Silver surcharge Difference between current price and basic value contained in product price.
AJ	Adjustments Description to be provided. GS1 Description: Allowance or charge related to adjustments.

Used Codes

ASS	Assortment allowance (GS1 Temporary Code) Allowance given when a specific part of a suppliers assortment is purchased by the buyer.
CA	Cataloguing services Description to be provided. GS1 Description: Allowance or charge related to the provision of cataloguing services.
CAC	Cash discount Discount incurring with cash payment.
CAG	Competitive allowance Price adjustment allowed for market conditions or factors.
CAI	Cutting charge Description to be provided. GS1 Description: An allowance or charge related to the service of cutting.
CAL	Payroll payment service Provision of a payroll payment service.
CAM	Cash transportation service Provision of a cash transportation service.
CAN	Home banking service Provision of a home banking service.
CAP	Insurance brokerage service Provision of an insurance brokerage service. GS1 Description: Charge or allowance paid to a bank, related to the purchase of insurance using the bank as a broker.
CAQ	Cheque generation service Provision of a cheque generation service. GS1 Description: Charge paid to a bank which relates to the generation of a cheque.
CAR	Preferential merchandising location Service of assigning a preferential location for merchandising.
CAS	Crane service Provision of a crane service.
CAT	Special colour service Providing a colour which is different from the default colour.
CAU	Sorting The provision of sorting services. EDIFACT

Used Codes

CAV	Battery collection and recycling The service of collection and recycling batteries.
CAW	Product Take Back Fee The fee the consumer must pay the manufacturer to take back the product.
CP	Competitive price Description to be provided. GS1 Description: Allowance or charge related to the availability of a competitive price.
DAE	Distributor discount/allowance Specific discount/allowance for distributors.
DBD	Debtor bound (GS1 Temporary Code) A special allowance or charge applicable to a specific debtor.
DDA	Dealer discount/allowance (GS1 Temporary Code) A discount or allowance offered by a party dealing a certain brand or brands of products.
DI	Discount A reduction from a usual or list price. GS1 Description: A discount is a reduction in the price of an item offered on a one off basis. An important distinction to make between discount and an allowance offered is that an allowance is a reduction which is offered on a regular basis.
DTC	Discount transferable to the consumer (GS1 Temporary Code) A discount given by the manufacturer which should be transferred to the consumer.
EAA	Early buy allowance Allowance granted to customers buying early.
EAB	Early payment allowance Allowance granted to customers paying early.
FA	Freight allowance Description to be provided. GS1 Description: Allowance for the shipment of goods or commodity.
FC	Freight charge Amount to be paid for moving goods, by whatever means, from one place to another, inclusive discounts, allowances, rebates, adjustment factors and additional cost relating to freight costs (UN/ECE Recommendation no 23).
FG	Free goods Allowance or rebate granted by delivery of goods free of charge.

Used Codes

FI	Finance charge Description to be provided. GS1 Description: A charge related to the provision of financing.
FR	Flat Rate (GS1 Temporary Code) A flat rate is applied.
GRB	Growth of business (GS1 Temporary Code) An allowance or charge related to the growth of business over a pre-determined period of time.
HD	Handling Charge for handling of the item.
IN	Insurance Charge for insurance.
INT	Introduction allowance (GS1 Temporary Code) An allowance related to the introduction of a new product to the range of products traded by a retailer.
IS	Invoice services Description to be provided. GS1 Description: An allowance or charge related to the provision of invoicing services.
LA	Labelling Service of labelling items.
MAC	Minimum order/minimum billing charge Description to be provided.
MB	Multi-buy promotion (GS1 Temporary Code) A code indicating special conditions related to a multi-buy promotion.
MC	Material surcharge (special materials) Description to be provided. GS1 Description: A surcharge related to the use of special materials.
NAA	Non-returnable containers Description to be provided. GS1 Description: An allowance or charge related to the use of non-returnable containers.
PAD	Promotional allowance Description to be provided. GS1 Description: An allowance related to a promotion.

Used Codes

PAE	Promotional discount Description to be provided. GS1 Description: A discount related to a promotion.
PAR	Partnership allowance (GS1 Temporary Code) An allowance or charge related to the establishment and on-going maintenance of a partnership.
PC	Packing Charge for packing.
PI	Pick-up allowance Description to be provided. GS1 Description: An allowance related to the pick up of goods.
PL	Palletizing Description to be provided. GS1 Description: An allowance or charge related to the palletization of goods.
PN	Pallet charge Description to be provided. GS1 Description: A charge related to the use of pallets.
QAA	Quantity surcharge Fee associated with providing goods outside "normal" quantity limits. GS1 Description: Fee associated with providing goods outside "normal" quantity limits.
QD	Quantity discount Description to be provided. GS1 Description: A discount related to the purchase of a specified quantity.
RAA	Rebate Description to be provided. GS1 Description: A rebate is the refund of part of an amount already paid for a product or service.
RAD	Returnable container Description to be provided. GS1 Description: An allowance or charge related to the use of returnable containers.
RAE	Resellers discount Description to be provided.
RCH	Return handling (GS1 Temporary Code) An allowance or charge related to the handling of returns.

Used Codes

SER	Service charge (GS1 Temporary Code) A charge related to the provision of a guarantee.
SH	Special handling service Description to be provided. GS1 Description: An allowance or charge related to the provision of special handling services.
TAE	Truckload discount Description to be provided. GS1 Description: A discount associated with the purchase or delivery of full trucks of a product or products.
TD	Trade discount Description to be provided. GS1 Description: A standard trade discount.
TX	Tax Contribution levied by an authority.
TZ	Temporary allowance Description to be provided. GS1 Description: An allowance which is available on a temporary basis.
VAB	Volume discount Discount offered based on the amount of purchase.
WHE	Wholesaling discount (GS1 Temporary Code) A special discount related to the purchase of products through a wholesaler.
X01	Allowance Global (GS1 Temporary Code) A global allowance is applied.
X02	Charge Global (GS1 Temporary Code) A global charge is applied.
X03	Consolidated (GS1 Temporary Code) A charge is consolidated.
X04	Lump sum (GS1 Temporary Code) A lump sum charge applied.
X05	Markup for small volume purchases (GS1 Temporary Code) A mark up is applied for small volume purchases.
X21	Special agreement (GS1 Temporary Code) Charge or allowance which relates to a special agreement.
X22	Bank charges information (GS1 Temporary Code) Charges not included in the total charge amount.

Used Codes

X23	Transfer commission (GS1 Temporary Code) Fee for the transfer of transferable documentary credits.
X29	Minimum order not fulfilled charge (GS1 Temporary Code) Charge levied because the minimum order quantity could not be fulfilled.
X30	Point of sales allowance (GS1 Temporary Code) Allowance for reaching or exceeding an agreed sales threshold at the point of sales.
X31	Remittance (GS1 Temporary Code) Charge or allowance related to the service of a payment carried out with a cheque from a city different to the city where the beneficiary has the account.
X32	National consignment (GS1 Temporary Code) Charge or allowance which relates to the service of a payment carried out outside the city where the account was opened.
X33	Local consignment (GS1 Temporary Code) Charge or allowance which relates to the service of a payment carried out within the city where the account was opened.
X40	Allowance/charge regulated by law (GS1 Temporary Code) An allowance/charge related to a regulatory requirement.
XAA	Combine all same day shipment Description to be provided. GS1 Description: An allowance or charge related to the combination of all same day shipments.
7233	Packaging related description code Code specifying information related to packaging.
1	Product ingredients not marked on package The ingredients of the product are not marked on the packaging of the product.
2	Product price not marked on packaging The product price is not marked on the packaging of the product.
3	Product best before date not marked on product package The product best before date is not marked on the packaging of the product.
4	Package not marked recyclable Package is not marked as recyclable.
5	Promotional details marked A code indicating that promotional details have been marked on the package.
7	Sell-by date marked on package The package is marked with the last date on which the item may be sold.

Used Codes

8	Use-by date marked on package The package is marked with the last date on which the item may be used.
9	Packaging / manufacturing date marked on package The package is marked with the date of the packaging or manufacturing of the item.
10	No freshness date marked on package Package is not marked with any kind of date indicating freshness, such as use-by, best before or packaging date.
31	Package best before date marked Package is marked with the product best before date.
32	Package marked recyclable The package is marked recyclable.
33	Package marked returnable The package is marked returnable.
50	Package barcoded EAN-13 or EAN-8 The package is barcoded with EAN-13 or EAN-8 code.
51	Package barcoded ITF-14 The package is barcoded with ITF-14 code.
52	Package barcoded UCC or EAN-128 The package is barcoded with UCC or EAN-128 code.
53	Package price marked The package is marked with the price.
54	Product ingredients marked on package The ingredients of the product contained in a package are marked on that package.
64	Package never EPC tagged. The package will never be tagged with an EPC (Electronic Product Code) transponder.
65	Package sometimes EPC tagged The package will sometimes be tagged with an EPC (Electronic Product Code) transponder.
78	Package bar-coded and EPC tagged The package is bar-coded and tagged with an EPC (Electronic Product Code) transponder.
79	Package EPC tagged only The package is tagged with an EPC (Electronic Product Code) transponder only.
80	Marked with "display until date" Package is marked with the date by which the product should be removed from the display location.

Used Codes

81	Package marked with a variable measure barcode The package is marked with a variable measure barcode.
82	Package marked with fixed measure barcode The package is marked with a fixed measure barcode.
LAB	Labeled according to General GS1 Specifications for clothing and fashion accessories (GS1 Temporary Code) The item is labeled according to the General GS1 Specifications for clothing and fashion accessories.
NAB	Not labeled acc. to GS1 (GS1 Temporary Code) Specifications for clothes and fashion accessoires
NBR	Not barcoded (GS1 Temporary Code) The package is not barcoded.
RL1	Peg hole round 1 (GS1 Temporary Code) The item's packaging has a round peg hole. (European norm DIN EN 13010:2003 (substitute for DIN 55512-1:1984-12))
SL1	Peg hole slot hole 1 (GS1 Temporary Code) The item's packaging has a slot peg hole of type 1. (European norm DIN EN 13010:2003 (substitute for DIN 55512-1:1984-12))
SL3	Peg hole slot hole 3 (GS1 Temporary Code) The item's packaging has a slot peg hole of type 3. (European norm DIN EN 13010:2003 (substitute for DIN 55512-1:1984-12))
X01	Composite Component A (GS1 Temporary Code) Packaging marked with CC-A barcode.
X02	Composite Component B (GS1 Temporary Code) Packaging marked with CC-B barcode.
X03	Composite Component C (GS1 Temporary Code) Packaging marked with CC-C barcode.
X04	RSS-14 (GS1 Temporary Code) Packaging marked with RSS-14 (GS1 DataBar) symbology.
X05	RSS-14 Stacked (GS1 Temporary Code) Packaging marked with RSS-14 (GS1 DataBar) stacked symbology.
X06	RSS-14 Staked omnidirectional (GS1 Temporary Code) Packaging marked with RSS-14 (GS1 DataBar) stacked omnidirectional symbology.
X07	RSS-14 Truncated (GS1 Temporary Code) Packaging marked with RSS-14 (GS1 DataBar) truncated symbology.
X08	RSS expanded (GS1 Temporary Code) Packaging marked with RSS (GS1 DataBar) expanded symbology.

Used Codes

X09	RSS expanded truncated (GS1 Temporary Code) Packaging marked with RSS (GS1 DataBar) expanded truncated symbology.
X10	RSS limited (GS1 Temporary Code) Packaging marked with RSS (GS1 DataBar) limited symbology.
X11	UPC A symbol (GS1 Temporary Code) Packaging marked with UPC A symbol.
X12	UPC E Symbol (GS1 Temporary Code) Packaging marked with UPC E symbol.
X13	EANUCC 14 Symbol (GS1 Temporary Code) Packaging marked with EAN UCC 14 symbology.
X14	Package not marked returnable (GS1 Temporary Code) Packaging marked with EAN UCC 14 symbology.
X15	Gift wrapping (GS1 Temporary Code) Trade item is packaged in a gift wrapping.
X16	Greeting card (GS1 Temporary Code) Trade item is accompanied by a greeting card.
8051	Transport stage code qualifier Code qualifying a specific stage of transport.
1	Inland transport Transport by which goods are moved from or to the frontier, or between inland points.
10	Pre-carriage transport Transport by which the goods are moved prior to their main carriage transport.
11	At border Transport by which goods are moved to the Customs frontier.
12	At departure Transport by which goods are moved from the place of departure.
13	At destination Transport by which goods are moved at the place of destination.
20	Main-carriage transport The primary stage in the movement of cargo from the point of origin to the intended destination.
25	Delivery carrier all transport Carrier responsible from the point of origin to the final delivery destination.
30	On-carriage transport Transport by which the goods are moved after the main carriage transport.

Used Codes

I	Origin switch carrier (GS1 Temporary Code) Carrier taking responsibility for the goods from the carrier which has transported them from their point of origin.
8067	Transport mode name code Code specifying the name of a mode of transport. Notes: 1. Use UN/ECE Recommendation No 19.
0	Transport mode not specified Transport mode has not been specified. Notes: 1) This code can be used when the mode is not known or when information on is not available at the time of issuing the document concerned.
1	Maritime transport Transport of goods and/or persons is by sea.
2	Rail transport Transport of goods and/or persons is by rail.
3	Road transport Transport of goods and/or persons is by road.
4	Air transport Transport of goods and/or persons is by air.
5	Mail Method to convey goods is by mail. Notes: 1) This code is provided for practical reasons, despite the fact that mail is not a genuine mode of transport. In many countries, the value of merchandise exported by mail is considerable, but the exporter or importer concerned would be unable to state by which mode postal items had been conveyed.
6	Multimodal transport Method to convey goods and/or persons is by multimodal transport. Notes: 1) This code is provided for practical reasons, despite the fact that multimodal transport is not a genuine mode of transport. It can be used when goods are carried by at least two different modes from a place at which the goods are taken in charge by a transport operator to a place designated for delivery, on the basis of one transport contract. (Operations of pick-up and delivery of goods carried out in the performance of a single mode of transport, as defined in such a contract, shall not be considered as multimodal transport).

Used Codes

7	Fixed transport installations Transport of item is via a fixed transport installation.
	Notes: 1) This code applies to installations for continuous transport such as pipelines, ropeways and electric power lines.
8	Inland water transport Transport of goods and/or persons is by inland water transport.
9	Transport mode not applicable The mode of transport is not applicable.
100	Courier service (GS1 Temporary Code) A courier service used to collect and deliver a consignment to its destination.
8179	Transport means description code Code specifying the means of transport.
1	Barge chemical tanker A barge equipped to transport liquid chemicals.
9	Exceptional transport Transport for which common characteristics are not applicable (e.g. big transformers requiring special wagons, special tackles, special routing etc.).
12	Ship tanker A large vessel equipped to transport liquids.
13	Ocean vessel
19	Tip-up truck A truck capable of tipping up in order to deliver its load.
20	Furniture truck A truck used explicitly for the conveyance of furniture.
21	Rail tanker A rail wagon equipped to transport liquids.
22	Rail silo tanker Self explanatory.
	Notes: This code value will be removed effective with directory D.04B.
23	Rail bulk car A rail wagon equipped to transport bulk cargo.
26	Tip-up articulated truck An articulated truck capable of tipping up in order to deliver its load.

Used Codes

28	Refrigerated truck and trailer A combined truck and trailer equipped to maintain refrigerated temperatures. GS1 Description: A truck and trailer capable of transporting refrigerated goods.
29	Freezer truck and trailer A combined truck and trailer equipped to maintain freezing temperatures. GS1 Description: A truck and trailer capable of transporting frozen goods.
30	Tautliner 25 tonne, combined with 90 cubic meter trailer with removable roof A truck with non-ridged sides, 25 tonne capacity combined with a 90 cubic meter trailer with removable roof.
31	Truck An automotive vehicle for hauling goods.
32	Road tanker An over-the-road tank trucker or trailer.
35	Truck/trailer with tilt A truck and trailer combination with a tilting capability. GS1 Description: A truck/trailer fitted with a tilting mechanism.
40	Truck with opening floor A truck with an opening floor mechanism which is used to discharge the cargo.
41	Freezer truck A truck equipped to maintain freezing temperatures.
42	Isothermic truck A truck equipped to maintain controlled temperatures.
43	Refrigerated truck A truck equipped to maintain refrigerated temperatures. GS1 Description: A truck capable of transporting refrigerated goods.
44	Freezer van A small rigid covered vehicle for conveying frozen goods. GS1 Description: A van capable of transporting frozen goods.
45	Isothermic van A small rigid covered vehicle for conveying temperature controlled goods. GS1 Description: A van capable of transporting temperature controlled goods.
46	Refrigerated van A small rigid covered vehicle for conveying refrigerated goods. GS1 Description: A van capable of transporting refrigerated goods.

Used Codes

47	Bulk truck A truck suitable for transporting bulk goods.
48	Van A small vehicle suitable for carrying small volume loads.
73	Train with more than one and less than 20 wagons A train with more than one and less than 20 wagons used to carry goods.
74	Train with 20 or more wagons A train with 20 or more wagons used to carry goods.
77	Freezer truck and isothermic trailer A combined freezer truck and isothermic trailer.
78	Isothermic truck and isothermic trailer A truck and a trailer equipped to maintain controlled temperatures.
79	Refrigerated truck and isothermic trailer A combined refrigerated truck and isothermic trailer.
80	Freezer truck and refrigerated trailer A combined freezer truck and refrigerated trailer.
81	Isothermic truck and refrigerated trailer A combined isothermic truck and refrigerated trailer.
82	Rigid truck with tank and tank trailer A combined rigid truck with tank and tank trailer.
83	Bulk truck and tank trailer A combined truck capable of carrying liquids or bulk goods and a tank trailer.
84	Rigid truck with tank and bulk trailer A combined rigid truck with tank and a trailer capable of carrying liquids or bulk goods.
85	Bulk truck and bulk trailer A combined truck and a trailer both capable of carrying liquids or bulk goods.
86	Tautliner truck and extendable trailer A combined tautliner truck and extendable trailer.
87	Tautliner truck with removable roof and extendable trailer A combined tautliner truck with removable roof and extendable trailer.
88	Truck with opening floor and extendable trailer A combined truck with opening floor and extendable trailer.
89	Bulk truck and extendable trailer A combined truck capable of carrying liquids or bulk goods and an extendable trailer.

Used Codes

90	<p>Isothermic truck and freezer trailer A combined isothermic truck and freezer trailer.</p>
91	<p>Refrigerated truck and freezer trailer A combined refrigerated truck and freezer trailer.</p>
92	<p>Tip-up truck and gondola trailer A combined tip-up truck and gondola trailer. A gondola trailer is a split level trailer suitable for the transport of heavy machinery.</p>
93	<p>Tautliner truck and gondola trailer A combined tautliner truck and gondola trailer. A gondola trailer is a split level trailer suitable for the transport of heavy machinery.</p>
94	<p>Tautliner truck with removable roof and gondola trailer A combined tautliner truck with removable roof and gondola trailer. A gondola trailer is a split level trailer suitable for the transport of heavy machinery.</p>
95	<p>Truck with opening floor and gondola trailer A combined truck with opening floor and gondola trailer. A gondola trailer is a split level trailer suitable for the transport of heavy machinery.</p>
96	<p>Bulk truck and gondola trailer A combined truck capable of carrying liquids or bulk goods and a gondola trailer. A gondola trailer is a split level trailer suitable for the transport of heavy machinery.</p>
97	<p>Tip-up truck and extendable gondola trailer A combined tip-up truck with extendable gondola trailer. An extendable gondola trailer is a trailer fitted with a rear axle which can be extended to cater for variable length and is suitable for the transport of heavy machinery.</p>
98	<p>Tautliner truck and extendable gondola trailer A combined tautliner truck and extendable gondola trailer. An extendable gondola trailer is a trailer fitted with a rear axle which can be extended to cater for variable length and is suitable for the transport of heavy machinery.</p>
99	<p>Tautliner truck with removable roof and extendable gondola trailer A combined tautliner truck with removable roof and extendable gondola trailer. An extendable gondola trailer is a trailer fitted with a rear axle which can be extended to cater for variable length and is suitable for the transport of heavy machinery.</p>
100	<p>Truck with opening floor and extendable gondola trailer A combined truck with opening floor and extendable gondola trailer. An extendable gondola trailer is a trailer fitted with a rear axle which can be extended to cater for variable length and is suitable for the transport of heavy machinery.</p>
101	<p>Bulk truck and extendable gondola trailer A combined truck capable of carrying liquids or bulk goods and a extendable gondola trailer. An extendable gondola trailer is a trailer fitted with a rear axle which can be extended to cater for variable length and is suitable for the transport of heavy machinery.</p>

Used Codes

102	Tip-up truck and trailer with opening floor A combined tip-up truck and trailer with opening floor.
103	Tautliner truck and trailer with opening floor A combined tautliner truck and trailer with opening floor.
104	Tautliner truck with removable roof and trailer with opening floor A combined tautliner truck with removable roof and trailer with opening floor.
106	Bulk truck and trailer with opening floor A combined truck capable of carrying liquids or bulk goods and a trailer with opening floor.
3138	Armoured vehicle Automotive vehicle designed with fortified body for enhanced protection.
10E	Tautliner 25t (GS1 Temporary Code) A 25t Tautliner truck/trailer.
11E	Tautliner 25t with removable roof (GS1 Temporary Code) A 25t Tautliner truck/trailer with removable roof.
12E	Articulated flat lorry 25t (GS1 Temporary Code) An articulated flat lorry capable of carrying loads of 25 tonnes.
13E	Articulated flat lorry 24t with crane 10m (GS1 Temporary Code) An articulated flat lorry with a 10 meter crane capable of carrying loads of 24 tonnes.
14E	Articulated flat lorry 24t with crane 15m (GS1 Temporary Code) An articulated flat lorry with a 15 meter crane capable of carrying loads of 24 tonnes.
15E	Articulated flat lorry 24t with crane 18m (GS1 Temporary Code) An articulated flat lorry with a 18 meter crane capable of carrying loads of 24 tonnes.
16E	Articulated flat lorry 10t (GS1 Temporary Code) An articulated flat lorry capable of carrying loads of 10 tonnes.
17E	Tautliner 25t with trailer 90m ³ (GS1 Temporary Code) A 25t Tautliner truck/trailer with a 90 m ³ trailer.
18E	Tautliner 25t with trailer 120m ³ (GS1 Temporary Code) A 25t Tautliner truck/trailer with a 120 m ³ trailer.
19E	Flat lorry with trailer and crane 10m (GS1 Temporary Code) An flat lorry with a trailer and a 10 meter crane.
20E	Articulated lorry with tank (GS1 Temporary Code) An articulated lorry fitted with a tank capable of carrying liquids or bulk goods..

Used Codes

21E	Flat lorry 15t (GS1 Temporary Code) A flat lorry capable of carrying loads of 15 tonnes.
22E	Flat lorry 25t with crane (GS1 Temporary Code) An flat lorry fitted with a crane and capable of carrying loads of 25 tonnes.
27E	Isothermic trailer (GS1 Temporary Code) A trailer capable of transporting temperature controlled goods.
28E	Refrigerated trailer (GS1 Temporary Code) A trailer capable of transporting refrigerated goods.
32E	Trailer (GS1 Temporary Code) A trailer suitable for transporting containerised or palletized goods.
33E	Tank trailer (GS1 Temporary Code) A tank trailer suitable for transporting liquids.
34E	Bulk trailer (GS1 Temporary Code) A trailer suitable for transporting bulk goods.
37E	Extendable trailer (GS1 Temporary Code) A trailer fitted with a rear axle which can be extended to cater for variable length loads.
38E	Dolly trailer (GS1 Temporary Code) A trailer composed of a platform mounted on an axle. The trailer is not connected directly to the truck but connected by the load.
39E	Freezer trailer (GS1 Temporary Code) A trailer suitable for transporting frozen goods.
41E	Furniture removal trailer (GS1 Temporary Code) A trailer used explicitly for the removal of furniture.
44E	Gondola trailer (GS1 Temporary Code) A split level trailer suitable for the transport of heavy machinery (e.g. earth movers).
45E	Extendable gondola trailer (GS1 Temporary Code) A trailer fitted with a rear axle which can be extended to cater for variable length loads and is suitable for the transport of heavy machinery (e.g. earth movers).
46E	Rigid lorry with tank (GS1 Temporary Code) A rigid lorry fitted with a tank capable of carrying liquids or bulk goods.
50E	Tautliner rigid truck (GS1 Temporary Code) A Tautliner rigid truck.
51E	Tautliner rigid truck with removable roof (GS1 Temporary Code) A Tautliner rigid truck with removable roof.

Used Codes

53E	Trailer with opening floor (GS1 Temporary Code) A trailer with an opening floor mechanism which is used to discharge the cargo.
54E	Train with convergent set of wagons (GS1 Temporary Code) A train with wagons coming from different despatch locations which must be grouped in order to form one train.
55E	Train with divergent set of wagons (GS1 Temporary Code) A train with wagons coming from the same despatch location which will be split in different trains because there are more than one point of delivery.
56E	Combination of a truck (length 6 m) and a trailer (length 8 m) (GS1 Temporary Code) Combination of a truck (length 6 m) and a trailer (length 8m) having a combined tonnage of between 23 and 25 tons and a loading capacity of 90m3.
57E	Combination of a truck (length 6 m) and a trailer (length 9 m) (GS1 Temporary Code) Combination of a truck (length 6m) and a trailer (length 9m) having a combined tonnage of between 23 and 25 tons and a loading capacity of 100m3.
58E	Combination of a truck and trailer with a length of 13.6m, a tonnage between 23 and 25 tons (GS1 Temporary Code) Combination of a truck and a trailer with a length of 13.6m, a tonnage between 23 and 25 tons, and a loading capacity of 80 m3.
59E	Rail wagon (GS1 Temporary Code) A single rail wagon used to carry goods.
77E	Furniture truck and trailer (GS1 Temporary Code) A combined truck and trailer capable of carrying furniture.
78E	Tautliner truck and furniture trailer (GS1 Temporary Code) A combined tautliner truck and furniture trailer.
79E	Tautliner truck with removable roof and furniture trailer (GS1 Temporary Code) A combined tautliner truck with removable roof and furniture trailer.
93E	Truck and trailer with opening floor (GS1 Temporary Code) A combined truck and a trailer with an opening floor.
95E	Tautliner truck and dolly trailer (GS1 Temporary Code) A combined tautliner truck and a dolly trailer.
96E	A tautliner truck with removable roof and a dolly trailer (GS1 Temporary Code) A combined tautliner truck with removable roof and a dolly trailer.
97E	Truck with trailer (GS1 Temporary Code) Combined truck and trailer.
98E	Truck with crane for moving goods without trailer (GS1 Temporary Code) A truck with a crane that enables to move goods, without trailer.

Used Codes

99E	Truck with crane for moving goods with trailer (GS1 Temporary Code) A truck with a crane that enables to move goods, with trailer.
X01	Truck with crane for lifting goods without trailer (GS1 Temporary Code) A truck with a crane that enables to lift goods, without trailer.
X02	Truck with crane for lifting goods with trailer (GS1 Temporary Code) A truck with a crane that enables to lift goods, with trailer.
X04	Courier express (GS1 Temporary Code) Use the fastest courier means possible.
X05	Road parcel express (GS1 Temporary Code) Parcel express service by road.
X06	Air freight (GS1 Temporary Code) Air freight delivery service.
X07	Surface air lifting (GS1 Temporary Code) Surface air lifting postal service.
X08	Air express (GS1 Temporary Code) Air express delivery service.
X09	Parcel post (GS1 Temporary Code) Postal service for the delivery of parcels.
X10	Mail express (GS1 Temporary Code) The express mail service of the postal service.
X11	Surface mail (GS1 Temporary Code) For non air mail international mailing.
X12	Accelerated surface mail (GS1 Temporary Code) Higher priority surface mail.
X13	Air mail (GS1 Temporary Code) Use air mail service.
X14	Printed matter/book post (GS1 Temporary Code) A special mailing service for printed matter or books.
X15	Parcel delivery registered (GS1 Temporary Code) Service for the delivery of registered parcels
X16	Parcel delivery express service registered (GS1 Temporary Code) Express service for the delivery of registered parcels
X3	Truck up to 3,5 tons (GS1 Temporary Code) A truck with a total weight up to 3,5 tons.
X4	Miscellaneous transport means (GS1 Temporary Code) Miscellaneous means of transport not further defined.

Used Codes

8395	Returnable package freight payment responsibility code Code specifying the responsibility for the freight payment for a returnable package.
1	Paid by customer Self explanatory.
2	Free Self explanatory.
3	Paid by supplier The responsibility for the freight for returning the packaging is to be paid by the supplier.

Example

UNA:+.?'

The UNA segment contains the default service string characters.

UNB+UNOC:3+4012345000009:14:4012345000018+4000004000002:14:4000004000099+181013:1043+4711+REF:AA++++EANCOM+1'

The EANCOM file 4711 dated 13.10.2018, 10 h 43 is sent by the issuer identified with GLN 4012345000009 to the receiver identified with GLN 4000004000002.

UNH+1+ORDRSP:D:01B:UN:EAN009'

Identification data of the ORDRSP message. The message reference number "1" must be repeated in the UNT segment at the end of the message.

BGM+231:::X+128222+29'

The order response has the number 128222.

DTM+137:20181020:102'

Date of the order confirmation is the 20th of October 2018.

DTM+2:20181028:102'

Requested delivery date now is the 28th of October 2018.

DTM+64:201810230800:203'

The earliest delivery date/time is the 23th of October 2018 at 8.00 a.m.

DTM+63:201810291500:203'

The latest delivery date/time is the 29th of October 2018 at 3.00 p.m.

DTM+61:201810230800:203'

The example request the cancellation if not delivered until the 23th of October 2018 at 8.00 a.m.

DTM+11:20181028:102'

Date of delivery is the 28th of October 2018.

DTM+67:20181028:102'

Delivery date / time, current schedule is the 28th of October 2018.

ALI+++X2'

Partial order allowed.

RFF+ON:4711'

The message references to the order number 4711.

DTM+171:20180301:102'

Buyers order is dated the 01th of March 2018.

RFF+CR:4711'

The order response is based on order reference no. 4711.

RFF+SS:4711'

The order response is based on sellers reference no. 4711.

RFF+VN:4711'

The order response is based on order number of the supplier no. 4711.

RFF+PD:4713'

The message references to the promotion deal number 4713.

RFF+AXO:AT-N-01-BIO'

The message contains only BIO products. All of them are certified by the control agency AT-N-01-BIO, as long as no other information is given at line level.

NAD+SU+4012345000009::9+ABC123:X:X:X:X'

Example

The supplier/manufacturer is identified by Global Location Number (GLN) 4012345000009.

RFF+GN:HRB-471111'

German statements on business letters: HRB-471111

RFF+VA:DE101010'

The VAT registration number is DE101010.

RFF+YC1:12345'

The additional party identification (supplier) is 12345.

NAD+BY+4398765000004::9+X:X:X:X:X'

The order is generated by a buyer with the Global Location Number (GLN) 4398765000004.

RFF+GN:HRB-471111'

German statements on business letters: HRB-471111

RFF+IT:22369'

The internal customer number in suppliers system is 22369.

RFF+YC1:22369'

The additional party identification (customer) is 22369.

CTA+PD+Claus Früh'

Buyers contact person is Claus Früh.

COM+kölsch@früh.de:EM'

E-mail of Mr. Früh is kölsch@früh.de

NAD+IV+4071615192710::9'

Invoicee is identified by GLN 4071615192710.

NAD+DP+4399899175941::9++EDI-LAND:Herr Laufen:Garage+Bussardweg 5+Leopardshöhle++33818+DE'

The receiver is identified by Global Location Number (GLN) 4399899175941. An address in clear text is only allowed in exceptional cases.

RFF+YC1:45698'

The internal identification for the receiver is 45698.

RFF+IT:313131'

The internal customer number in the supplier system for the receiver is 313131.

CTA+PD+Claus Früh'

Contact person is Claus Früh.

COM+kölsch@früh.de:EM'

E-mail of Mr. Früh is kölsch@früh.de

NAD+PW+4089876511111::9++Abholstelle-Name 1:Abholstelle-Name 2:Abholstelle-Name 3+Maarweg 104+Köln++50825+DE'

The collection place is identified by Global Location Number (GLN) 4089876511111.

RFF+YC1:0816'

The additional identification is 0816.

NAD+UC+4399899175941::9++EDI-LAND:Herr Laufen:Garage+Bussardweg 5+Leopardshöhle++33818+DE'

The ultimate consignee is identified by Global Location Number (GLN) 4399899175941. An address in clear text is only allowed in exceptional cases.

TAX+7+VAT+123ABC++::19+S'

Example

The dominant tax rate of the document is 19%.

CUX+2:EUR:9'

Order Currency is EURO

PAT+3'

Fixdate for payment

DTM+209:20181028:102'

Value date is the 28th of October 2018.

PAT+7++5:3:D:30'

Value: 30 days after invoice date

TDT+20+++48+4012345123456::9:Transport GmbH Schnelle Bücher'

road parcel express: "Transport GmbH Schnelle Bücher"

LOC+301+::91:DE1235891257322H0H422598442568863'

International meter identification

LIN+1+5+4000004000035:SRV'

The ordered item with the item number 1 is identified with the GTIN 4000004000035 was accepted without amendment.

PIA+5+ABC5343:SA::91'

Only if LIN does not provide a GTIN: Item identification in PIA

PIA+5+ABC5343:IN::92'

Only if LIN does not provide a GTIN: Item identification in PIA

PIA+3+4025894315970:SRV::9'

Substitute article GTIN

PIA+1+7788:SA::91'

The product with GTIN 4000004000035 is additionally identified with suppliers article number 7788.

PIA+1+1234:IN::92'

The product with GTIN 4000004000035 is additionally identified with buyers article number 1234.

PIA+1+4056786542381:PV::9'

The product identified with GTIN 4000004000035 is a promotional variant.

PIA+1+4711:GB::92'

The article belongs to the class of goods "4711"

IMD+A++:::Rudi Rüssel::DE'

Article long description: Rudi Rüssel, king of noses

IMD+B+SGR::9+XXL::91:::DE'

The item has the size XXL

MEA+PD+LAY+H87:5'

Number of layers per charge carrier is "5"

MEA+PD+ULY+H87:5'

Number of units per layer is "5"

MEA+AAI+AAA+GRM:6370'

The weight of the article is 63.7 kg net.

QTY+21:20'

Example

The originally ordered quantity amounts to 20 pieces.

QTY+12:10'

The despatched quantity amounts to 10 pieces.

QTY+83:10'

The backorder quantity amounts to 10 pieces.

QTY+192:20'

The free quantity amounts to 20 pieces of the article no. described in the LIN segment. (GTIN).

DTM+364:200:804'

Minimum remaining time / shelf-life of quantity is 200 days.

DTM+2:20181028:102'

This example requires the delivery on 28th of October 2018.

DTM+64:201810230800:203'

This example requires the delivery at the earliest time on 23th of October 2018 at 8.00 a.m.

DTM+63:201810291500:203'

This example requires the delivery at the latest time on 29th of October 2018 at 3.00 p.m.

DTM+61:201810230800:203'

The example request the cancellation if not delivered until 23th of October 2018 at 8.00 a.m.

DTM+11:200181028:102'

This example announces the delivery on 28th of October 2018.

DTM+44:20181028:102'

The article is available on 28th of October 2018.

DTM+67:20181028:102'

The schedule (Detail section) is available on 28th of October 2018.

QVR+-4:21+BP+BJ'

The quantity difference is 4 units.

FTX+PUR+1+DUN:MEDIA:246'

Do not record dues.

FTX+DEL+1+15:BOEV:246'

Reason for change

PRI+AAA:10::LIU'

Net list purchase price: 10 EURO

PRI+AAA:17.58'

The net sale price per piece is 17.58 EURO excl. tax.

CUX+2:EUR:10'

Price Currency is EURO

PRI+AAE:19.98:CA:SRP'

The recommended gross retail price per piece is 19.98 EURO incl. tax.

CUX+2:EUR:10'

Price Currency is EURO

PRI+AAE:19.98:CA:RTP'

Example

The fixed retail price per piece is 19.98 EURO incl. tax.

CUX+2:EUR:10'

Price Currency is EURO

RFF+CR:4711'

The order reference for the position of the order response is 4711.

RFF+SS:4711'

The order response line is based on sellers reference no. 4711.

RFF+SD:4711'

The order response line is for department 4711.

RFF+PD:4711'

The order response line is based on promotion deal no. 4711.

RFF+LI:4711:X'

The order line is based on line item reference 4711.

RFF+AXO:AT-N-01-BIO'

The article is a BIO product. It is certified by the control agency AT-N-01-BIO. The indication overwrites information of the heading section.

PAC+9+:50+BX::9++1'

The order line contains of 9 boxes marked with EAN-13.

TAX+7+VAT+123ABC++:::19+S'

The VAT rate for the current line item is 19%.

NAD+GZ+4089876986411:::9'

The substitute supplier is identified by GLN 4089876986411.

ALC+A++++DI'

Condition for information: Allowance

PCD+3:5'

5 percent

MOA+25:220'

Basis amount: 220 EURO

UNS+S'

Separation between detail and summary section

MOA+79:200'

The total line itme amount is 200 EUR.

UNT+101+1'

Number of segments in the message.

UNZ+1+4711'

The transmission file contains 1 message.
